

Freedom 2100 motor control center installation and maintenance manual



Contents

Part	Description	Page
1	General information.	2
2	Receiving, handling, and storage	4
3	Installing control center sections	5
4	Installing conduit and wiring	9
5	Incoming line connections	11
6	Overcurrent protection devices.	14
7	Overload relay heater selection.	16
8	Inspection prior to energizing	19
9	Unit installation and adjustment	20
10	Maintenance	22
11	Plan views.	27
12	Related instructional leaflets.	29
13	Arc resistant LV MCC	29
14	Contacting Eaton.	31

This electrical control equipment is designed to be installed, operated, and maintained by adequately trained workmen. These instructions do not cover all details, variations, or combinations of the equipment, its storage, delivery, installation, check-out, safe operation, or maintenance. Care must be exercised to comply with local, state, and national regulations, as well as safety practices, for this class of equipment. The maximum short circuit capability of the equipment should not be exceeded by connection to a source with higher capacity. If maintenance or troubleshooting assistance is required, contact your nearest Eaton sales office.

Part 1. General information

The motor control center

The Eaton Freedom 2100 motor control center may be joined to existing Five Star, Series 2100, and Advantage installations using the splice bar kits common to both. Units designed for the Freedom 2100 can be mounted in Five Star Series and Series 2100 sections, but the opposite is not recommended, because Five Star and Series 2100 units may lack terminal blocks and sufficient interrupting capacity. The Freedom 2100 MCC may be joined to existing Eaton Freedom Unitrol and F10 Unitrol MCCs with a special splice bar kit, but units are not interchangeable.

Control center nomenclature

The numbers shown in parentheses in the following text refer to the balloon legends in **Figure 2**.

The Eaton Freedom 2100 motor control center consists of one or more totally enclosed, dead front, free standing structural assemblies 90 inches high which are compartmentalized to house individual control units. (2) With control units mounted in the front side only, the structure may be 16 or 21 inches deep. For mounting units back-to-back, the structure is 21 inches deep. Steel covers (7) enclose the structure at the top, sides and at the rear of front-mounted-only structures.

A vertical bus system installed in each vertical section is connected to the horizontal bus to feed the individual control units. The vertical bus is isolated by a full height barrier. (6) An optional labyrinth barrier provides both isolation and insulation. An automatic shutter is included with the labyrinth barrier system to cover the stab openings for each control unit.

At the top of each section, a door provides ready access to the top horizontal wireway (11) and ground bus. The horizontal wireway is isolated from the bus systems by steel barriers which can be removed for installation and maintenance operations. Adequate space is provided for control wiring and top cable entry.

At the bottom of each section, a door (18) provides ready access to the bottom horizontal wireway, and neutral bus (if provided). The bottom of each section is completely open to provide unrestricted bottom entry of cable and conduit. Channel sills may be installed across the bottom of the control center if specified, and an optional bottom plate may also be specified.

A vertical wireway 8 inches deep, extending the full 90 inch height of the control center is located to the right of each unit compartment. This wireway is covered by two hinged doors (15) and contains cable supports to secure wire bundle and cables. The vertical wireway joins the horizontal wireway at the top and bottom to provide unobstructed space for interwiring.

Each vertical section provides space to mount up to six controller units (2) with a minimum height of 12 inches, in increments of six inches, for a total of 72 inches of usable space. Controllers through NEMA® Size 5 are drawout type (except reduced-voltage starters). These drawout unit assemblies are a completely self-contained package consisting of a steel enclosure, operating handle and electrical components. The drawout assembly slides into this compartment on guide rails (11) to provide easy withdrawal and reinsertion and to ensure precise alignment of the unit stabs with the vertical bus. Each drawout unit is held in place by a single quarter-turn latch (4) which can only be gaged when the unit stabs are fully mated with the vertical bus. Each unit has a separate door, (1) held closed by a minimum of two quarter-turn fasteners.

The operating handle on the controller unit (3) moves vertically. In the ON or TRIPPED positions, the handle interlocks with the unit door to prevent its opening. In this position, authorized personnel can open the door by turning the defaeter mechanism screw. (21) With the unit door open and the operating handle in the ON position, another interlock to the divider pan prevents removal of the unit. This same interlock prevents insertion of the unit unless the handle mechanism is in the OFF position. To ensure that units are not energized accidentally or by unauthorized personnel, the handle mechanism can be padlocked in the OFF position. Space for a minimum of three padlocks is provided on each handle. The device panel (5) is mounted on the drawout unit. It will accommodate up to six pilot devices. The overload reset button is mounted on the unit door.



Figure 1. Nameplate

Ratings

Each Freedom 2100 motor control center has a rating nameplate attached to the door of the top horizontal wireway of the primary section. See **Figure 1** and **Figure 2**. This nameplate shows the general order number under which the motor control center was built and its continuous electrical ratings, in terms of incoming line voltage, phases, and frequency, and ampere ratings of the horizontal bus and the vertical bus for each section. In addition, this nameplate shows the passive short-circuit (withstand) rating of the horizontal and vertical bus system. The active short-circuit (interrupting) ratings of the main and unit short-circuit protective devices are shown on labels attached to the inside of each unit. Before installing a motor control center, calculate and record the fault current available at the incoming line terminals. Verify that the short-circuit with standard short-circuit interrupting ratings of the units in the motor control center are appropriate for the fault current available.

Qualified personnel

Individuals who install, operate, or maintain MCCs must be trained and authorized to operate the equipment associated with the installation and maintenance of an MCC, as well as the operation of the equipment that receives its power from controller units in the MCC. Such individuals must be trained in the proper procedures with respect to disconnecting and locking OFF power to the MCC and wearing personal protective equipment, which includes arc flash, insulating, and shielding materials, and also use insulated tools and test equipment, following established safety procedures as outlined in the National Electrical Safety Code (ANSI C2) and Electrical Equipment Maintenance (NFPA 70E).

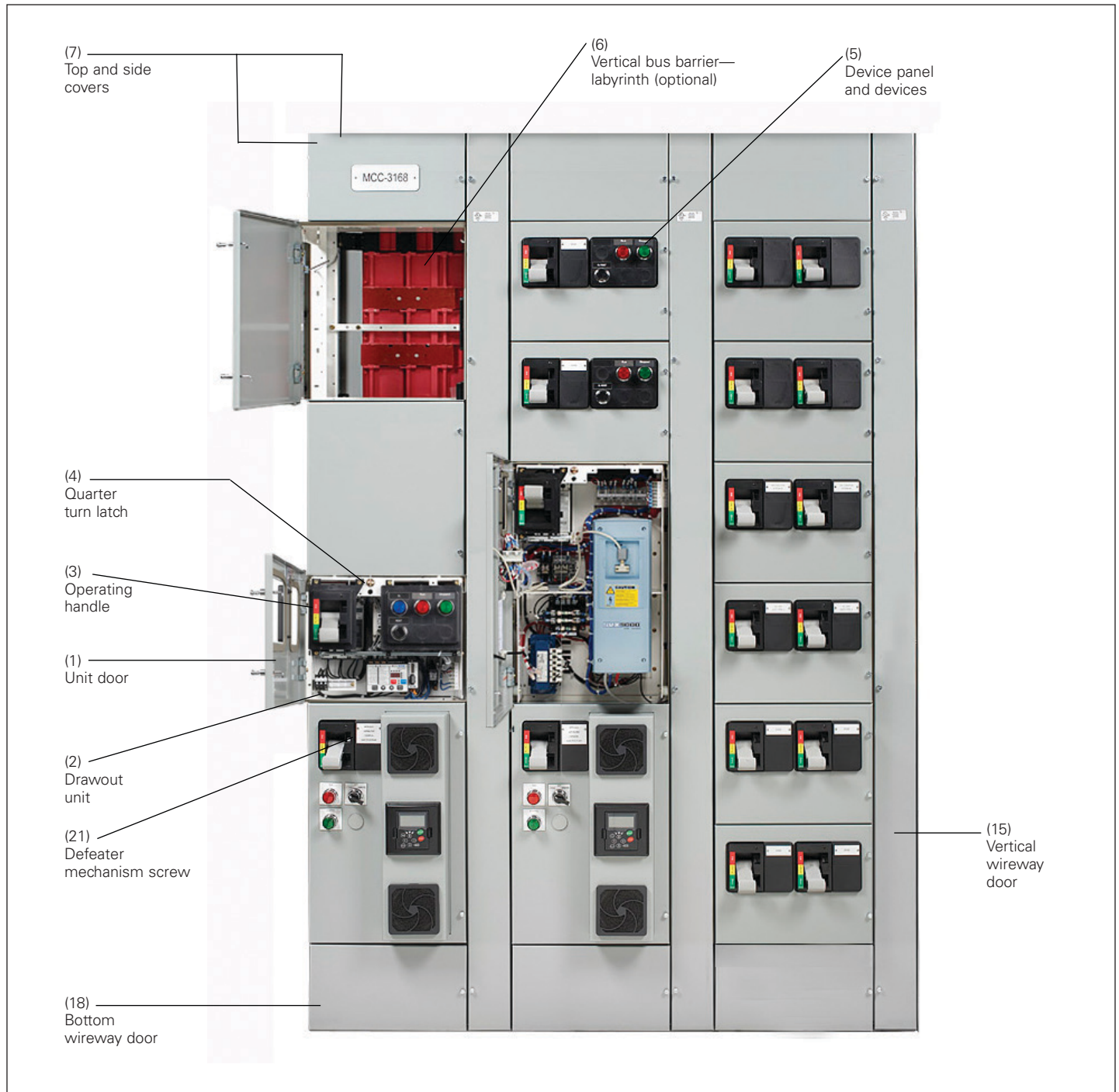

Figure 2. Motor control center nomenclature

Part 2. Receiving, handling, and storage

⚠ WARNING

MCC—HEAVY EQUIPMENT STATEMENT

THIS MCC CAN WEIGH IN EXCESS OF 2,000 POUNDS. REFER TO SHIPPING MANIFESTS FOR EXACT WEIGHT OF EQUIPMENT. TO PREVENT SERIOUS INJURY OR DEATH, OR EQUIPMENT DAMAGE, FROM UNINTENDED MOVEMENT OF EQUIPMENT DURING TRANSPORT, INSTALLATION OR ANY OTHER OPERATIONS, ENSURE THAT (1) ONLY MATERIAL HANDLING EQUIPMENT OF ADEQUATE CAPACITY AND RATING FOR THE LOAD INVOLVED IS USED; (2) ONLY QUALIFIED PERSONNEL ARE INVOLVED; AND (3) ALL LIFTING/BRACING SHIPPING LABELS AND MARKINGS INSTRUCTIONS SHIPPED WITH THE MCC MUST BE FOLLOWED.

Receiving

Before and after unloading the motor control center, inspect each section and unit exterior for evidence of damage that may have been incurred during shipment. If there is any indication that the control center has been mishandled or shipped on its back or side, remove the drawout units and make a complete inspection of the internal structure, bus bars, insulators, and unit components for possible hidden damage. Report any damage found to the carrier at once.

Handling

The following guidelines are provided to help avoid personal injury and equipment damage during handling, and to facilitate moving the motor control center at the job site.

General hints

1. Handle the motor control center with care to avoid damage to components and to the enclosure or its paint finish.
2. Keep the motor control center in an upright position.
3. Ensure that the moving means has the capacity to handle the weight of the motor control center.
4. The control center should remain secured to the shipping skid until the motor control center is in its final location.
5. Exercise care during any movement and placement operations to prevent falling or unintentional rolling or tipping.
6. Lifting angles for handling by overhead crane are bolted to the top of each shipping section. Handling by overhead crane is preferable, but when crane facilities are not available, the motor control center can be positioned with a fork-lift truck or by using rollers under the shipping skid.

Overhead crane

1. See **Figure 3** for recommended lifting configuration.
2. Select or adjust the rigging lengths to compensate for any unequal weight distribution, and to maintain the motor control center in an upright position.
3. To reduce tension on the rigging and the compressive load on the lifting angles, do not allow the angle between the lifting cables and vertical to exceed 45 degrees. Use slings with safety hooks or shackles. **Do not pass ropes or cables through lifting angle holes.**

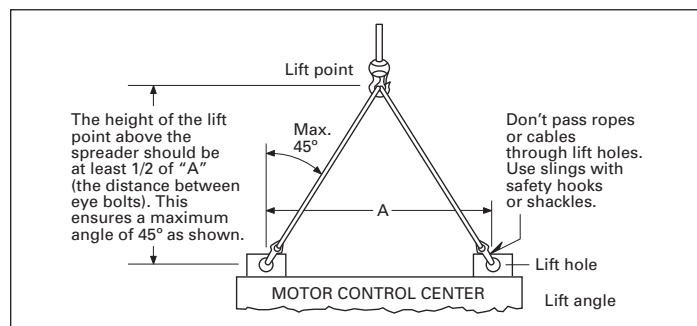

Figure 3. Correct use of lifting angle

4. After removing the lifting angles, replace the mounting hardware to prevent the entrance of dirt, etc.

Fork-lift truck

Motor control centers are normally top and front heavy. Balance the load carefully, and steady, as necessary, while moving. Always use a **safety strap when handling with a fork-lift.**

Rollers

Rod or pipe rollers, with the aid of pinch bars, provide a simple method of moving the motor control center on one floor level, if there is no significant incline. Roll the motor control center slowly, and steady the load to prevent tipping.

Storage

When a motor control center cannot be installed and placed into operation immediately upon receipt, take steps to prevent damage by condensation or harsh environmental conditions. If the motor control center cannot be installed in its final location, store it in a clean, dry, ventilated building, heated to prevent condensation, and protected from dirt, dust, water, and mechanical damage. When storage conditions are less than ideal, install temporary electrical heating, typically in the form of light bulbs, totaling 150 watts per section, hung in the vertical wireway, or by applying power to self-contained space heaters that the motor control center may be equipped with. Remove all loose packing and flammable materials before energizing any of the heating elements.

Part 3. Installing control center sections

General

Freedom FlashGard™ motor control centers (MCCs) are designed for installation in accordance with both the National Electrical Code® (NEC®), NFPA 70, and the National Electrical Safety Code (NESC), ANSI C2.

CAUTION

IF WORK IS INVOLVED IN CONNECTING THE CONTROL CENTER WITH EXISTING EQUIPMENT, ENSURE THAT INCOMING POWER IS DISCONNECTED BEFORE WORK BEGINS. DISCONNECTING MEANS SHOULD BE LOCKED OUT AND/OR TAGGED OUT OF SERVICE. WHERE IT IS NOT FEASIBLE TO DE-ENERGIZE THE SYSTEM, THE FOLLOWING PRECAUTIONS SHOULD BE TAKEN:

- A. Persons working near exposed parts that are or may be energized should be instructed and should use practices (including appropriate personal protective equipment, which includes arc flash, insulating, and shielding materials, and insulated tools and test equipment in accordance with the NFPA 70E).
- B. Persons working on exposed parts that are or may be energized should, in addition, be qualified persons who have been trained to work on energized circuits.

Installation

1. Before any installation work begins, consult all drawings furnished by Eaton, as well as all applicable contract drawings for the installation. Give particular attention to the physical location of units in the control center and their relation to existing or planned conduit, busways, etc. Provide for future conduit entrance prior to control center installation.
 2. Locate the control center in the area shown on the building floor plans. If in a wet location or outside of the building, protect the control center from water entering or accumulation within the enclosure. Recommended clearances or working spaces are as follows:
 - a. Clearance from walls (where not rear accessible)—a minimum of 1/2 inch for indoor and 6 inches for outdoor or wet locations.
 - b. Clearance from front of MCC (working space)—minimum of 3 feet for control centers without exposed live parts. See NEC 110.13.
 - c. For arc resistant MCCs up to 2500 A horizontal bus, there are no restrictions on the clearance above the MCC top plate. Standard Freedom MCC rules apply for conduit, cable trays, and wiring.
- Note:** This working space should not be used for storage and should have adequate lighting.
3. Since MCCs are assembled at the factory on smooth and level surfaces to ensure correct alignment of all parts, MCCs should be securely mounted on a level surface. The foundation furnished by the purchaser must be true and level, or the bottom frames must be shimmed to support the entire base in a true plane. It is recommended that leveled channel sills under both the front and rear of the control center be used to provide this level base. Drill and tap the channel sills for mounting bolts in accordance with the applicable floor plan drawing and then either install the MCC level with, or on top of, the finished floor. If sills are grouted in concrete, the mounting bolts should be screwed in place and remain until the concrete has hardened.

4. For bottom entry, position the MCC so that the conduit stubs or floor openings are located in the shaded areas shown on the MCC floor plan drawings (refer to **page 27** and **page 28** for floor plan dimensions). The shaded areas represent the open space available for conduit entry through the bottom of each section. A shaded area may be restricted if large controllers or auto-transformers are mounted in the bottom of the sections. If optional bottom plates are supplied, the plates may be removed and drilled for conduit entry.
5. Install the MCC in its final position, progressively leveling each section and bolting the frames together if they are separated. If necessary, secure the MCC to walls or other supporting surfaces. Do not depend on wooden plugs driven into holes in masonry, concrete, plaster, or similar materials. See NEC 110.13.
6. If two or more shipping sections are to be joined into an integral assembly or a shipping section is to be joined to an existing section, refer to paragraphs below before proceeding with the installation.
7. Ground and bond the MCC as follows:
 - a. MCCs used as service equipment for a grounded system or as an incoming line section for a separately derived, previously grounded system:
 1. Run a grounding electrode conductor (ground wire) having a size in accordance with NEC 250.94 from the grounding electrode to the MCC ground bus or ground terminal provided. See also NEC 250.92(A) and 92(B).
 2. If the system is grounded at any point ahead of the MCC, the grounded conductor must be run to the MCC in accordance with NEC 250, and connected to the ground bus terminal.
 3. Do not make any connections to ground on the load side of any neutral disconnecting line or any sensor used for ground-fault protection. Do not connect outgoing grounding conductors to the neutral.
 - b. MCCs used as service equipment for an ungrounded system or as an incoming line section for a separately derived, previously ungrounded system:
 1. Run a grounding electrode conductor (ground wire) having a size in accordance with NEC 250.94 from the grounding electrode to the MCC ground bus terminal. See NEC 250.92(A) and 92(B).
 - c. MCCs not used as service equipment nor as an incoming line section for a separately derived system, and used on either a grounded or ungrounded system:
 1. Ground the MCC ground bus by means of equipment grounding conductors having a size in accordance with NEC 250.95 or by bonding to the raceway enclosing the main supply conductors in accordance with NEC 250.92(B).
8. When all wiring and adjustments are complete, close all unit and wireway doors.
9. In damp indoor locations, shield the MCC to prevent moisture and water from entering and accumulating.
10. Unless the MCC has been designed for unusual service conditions, it should not be located where it will be exposed to ambient temperatures above 40 °C (104 °F), corrosive or explosive fumes, dust, vapors, dripping or standing water, abnormal vibration, shock, or tilting.

Joining compatible sections

If two more shipping sections are to be joined into an integral assembly, or a section added to an existing installation, splicing of horizontal bus, ground bus, neutral bus, and joining of the adjacent vertical sections must be planned with the installation.

1. Remove the side sheets from adjacent vertical sections to be joined. (These sheets will have been removed from factory-assembled sections.)
2. The horizontal bus splice plates and connection hardware will be shipped with the MCC attached to one end of shipping section. Refer to **Figure 4**.
3. This method provides the most convenient access to the bolts, and eliminates the need to remove the horizontal bus barriers in that structure. Should the existing bus be oxidized, sand lightly with a fine aluminum oxide paper.

⚠ CAUTION

DO NOT USE EMERY CLOTH OR ANY ABRASIVE CONTAINING METAL.

4. Remove the upper horizontal wireway door from the structure on the right side of the left-hand (LH) section, and remove the two-piece wireway barrier to provide access to the ends of the bus in that section.
5. Move the section into place, aligning the upright structural channels and bottom channels. Alignment of the section with floor sills and foundation provisions will be facilitated by removing the bottom horizontal wireway doors. Using the "U" or "Z" type frame clamps provided, clamp adjacent front upright channels together at the top, bottom, and approximate center of the vertical structure. "U" or "Z" clamp placements must be placed 4 inches (101.6 mm) above or below the drawout unit—1/4 turn latch and unit interlock feature on the cover control module; see details on **page 28** bottom left-hand corner. This operation will be facilitated by removing the vertical wireway doors from the left-hand structure and one or more drawout units from the right-hand structure. See **Part 9, page 20**.
6. If rear access is available, "U" or "Z" clamps should also be used to clamp the rear upright channels together. In front-mounted-only structures, this will require removal of the adjacent back sheets. In a back-to-back-mounted structure, remove the vertical wireway doors and one or more drawout units as above.
7. Secure the sections to the floor sills or mounting bolts as provided for the installation.
8. Bolt the horizontal bus splice plates to the bus in the left-hand structure, torquing all bus splice bolts to 360 pound-inches (30 pound-feet). See **Figure 5**.
9. Replace all units, bus barriers, and doors.
10. If joining a new arc resistant section to the end of an existing arc resistant lineup, remove the 4-inch end section and add new arc resistant sections with new 4-inch arc section to the end of the lineup.

Joining incompatible sections

Joining a Freedom MCC to other equipment, such as Type W and 11-300 control centers, will usually involve a transition section installed between the two varieties of equipment. This transition section will be detailed on drawings provided by Eaton and the applicable contract drawings. If provided separately, it should be installed first. Review the overall installation task to determine whether the transition section should be attached to the existing equipment or to the Freedom FlashGard section, before it is moved into place, and select the sequence that will provide best access to bus splicing and joining of the structures.

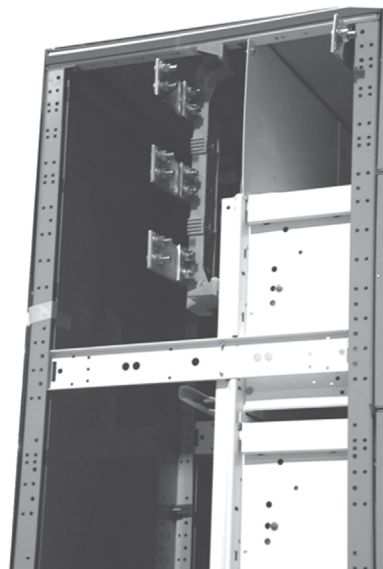

Figure 4. Splice plates attached to right-hand section

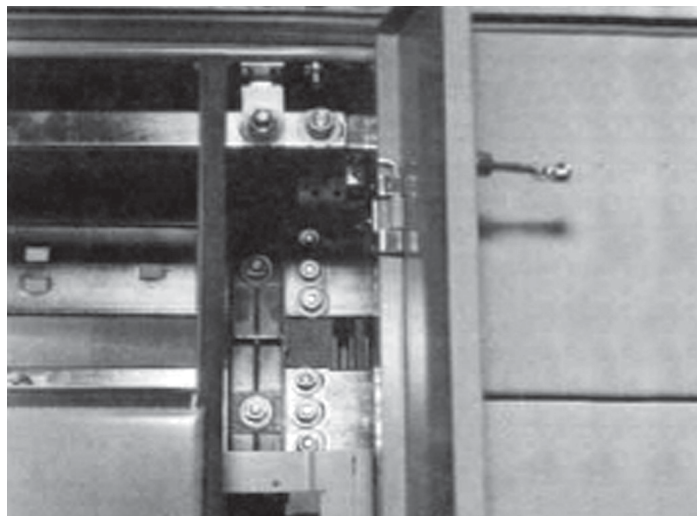

Figure 5. Access to left-hand splice plate connections

Splice plates

Each splice plate kit consists of short pieces of bus bar the same width as the main horizontal bus of the MCC the kit is shipped with, four bolts per phase, and appropriate quantities of related hardware. For a single bus bar per phase, the hardware is used as shown in **Figure 6** for either 16- or 21-inch deep enclosures. Each splice plate is punched with rectangular holes to accept a square shank carriage bolt that will not rotate as the nut is tightened.

Where the MCC is built with two horizontal bus bars per phase, the splice plates are installed as shown in **Figure 7**. The top edge of **Figure 7** through **Figure 10** represents the back side of the MCC. The top portion of each of these figures applies to 21-inch deep enclosures and the lower portion to 16-inch deep enclosures. Note that for all but the single-bar per phase (**Figure 6**) installation, the 16-inch deep enclosures require the use of a nut plate that is mounted with the same carriage bolt used to attach the horizontal bus bars to the channel-shaped insulators. Install these nut plates before mounting the splice plates. Tighten the splice plate bolts with a driving torque of 360 pound-inches (30 pound-feet).

Type 3R enclosures

Where the MCC is supplied in a Type 3R enclosure for an outdoor application, apply roof splice caps at each shipping block junction to maintain the enclosure integrity.

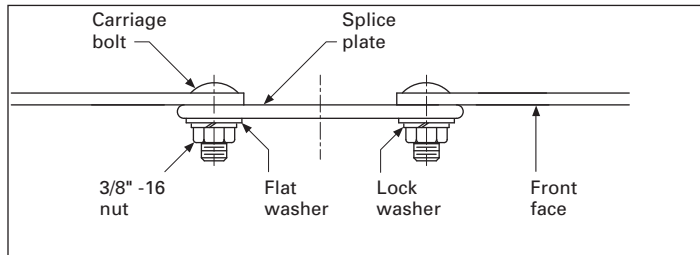

Figure 6. Single-bar splice kit

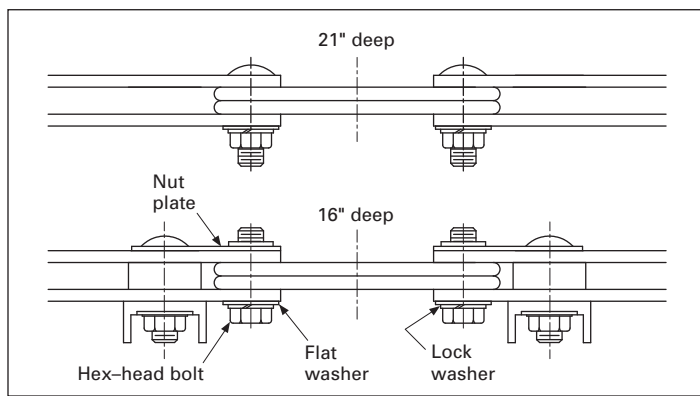

Figure 7. Double-bar splice kit

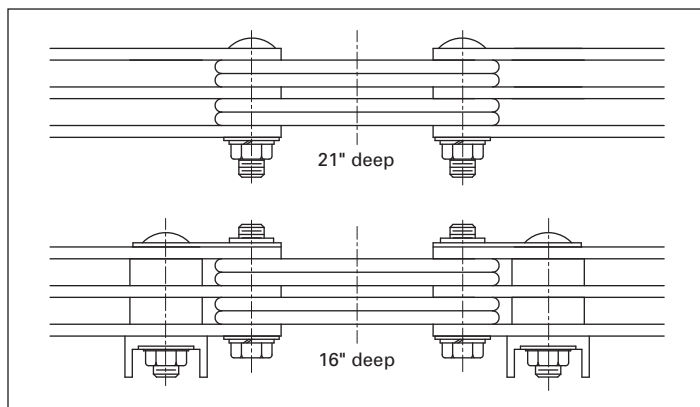

Figure 8. Triple-bar splice kit

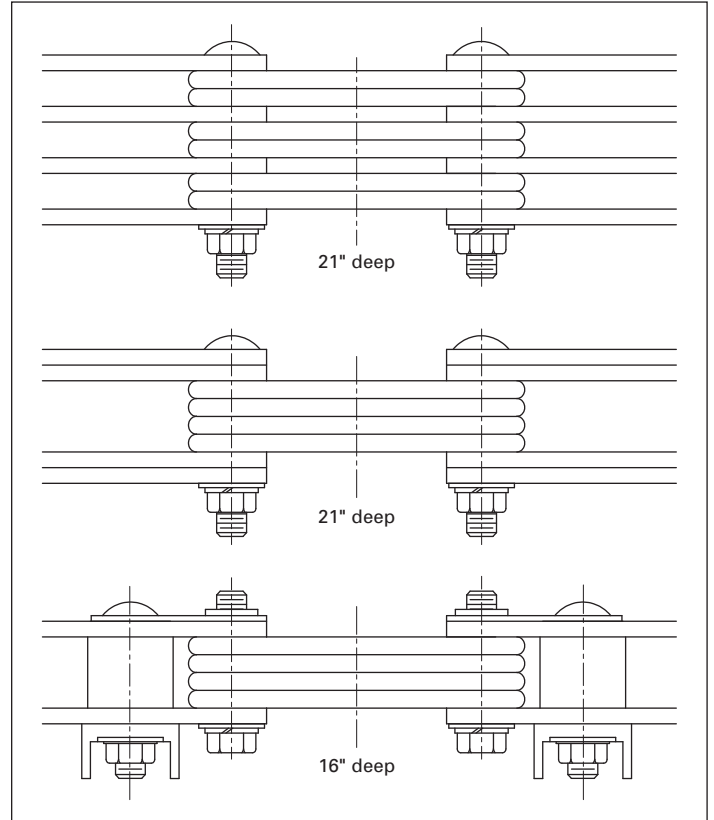

Figure 9. Quadruple-bar splice kits

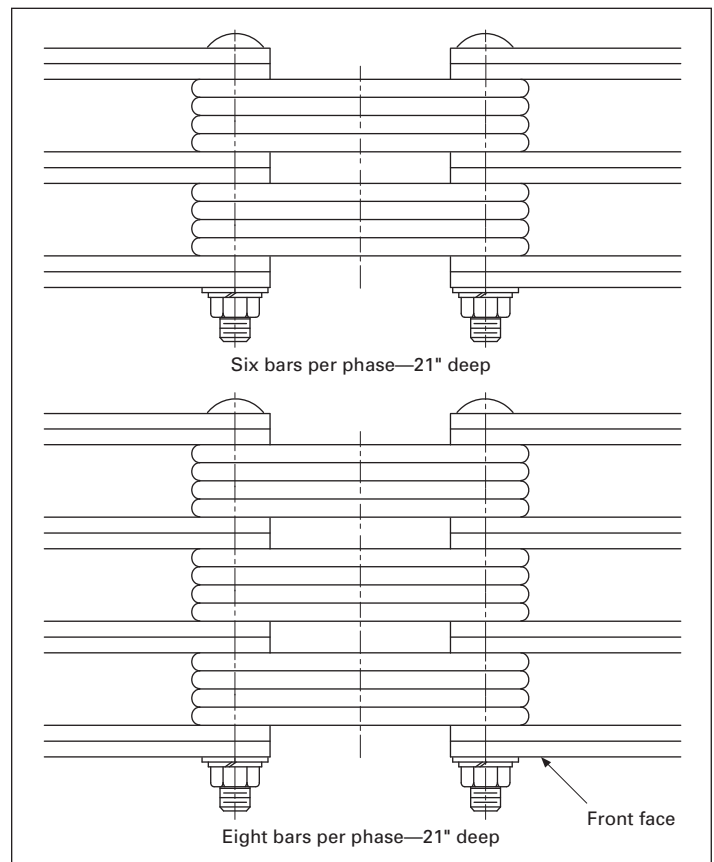

Figure 10. Six- and eight-bar splice kits

**Joining to a Freedom FlashGard, Freedom Unitrol,
or F10 Unitrol**

Consult the assembly instruction supplied with every Freedom MCC set up for splice to Freedom FlashGard, Freedom Unitrol, or F10 Unitrol.

⚠ WARNING

**SPECIFIC SAFETY NOTE FOR INSTALLING AND REMOVING MCC UNITS—
RECOMMEND THE USE OF NEW ACCESSORY.**

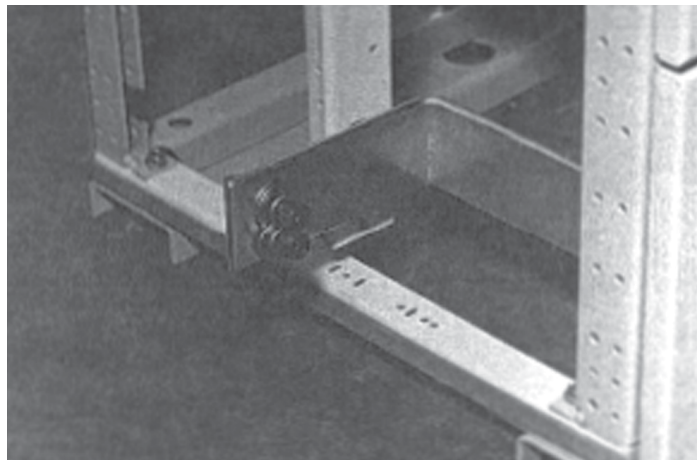

Figure 13. Splice plate attached to Freedom FlashGard ground bus at bottom

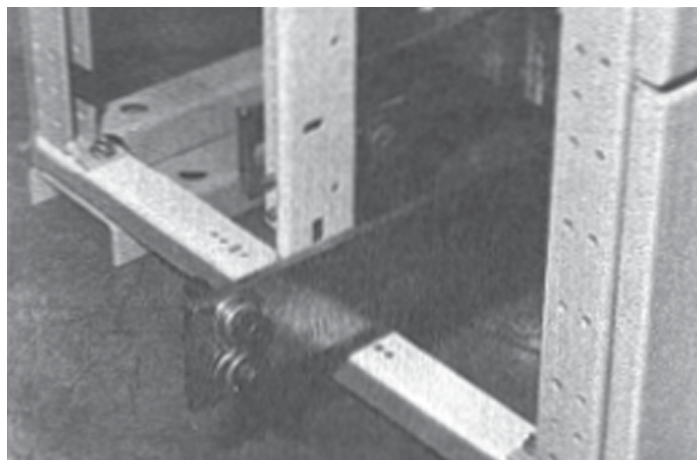

Figure 14. Splice plate attached to Freedom FlashGard neutral bus

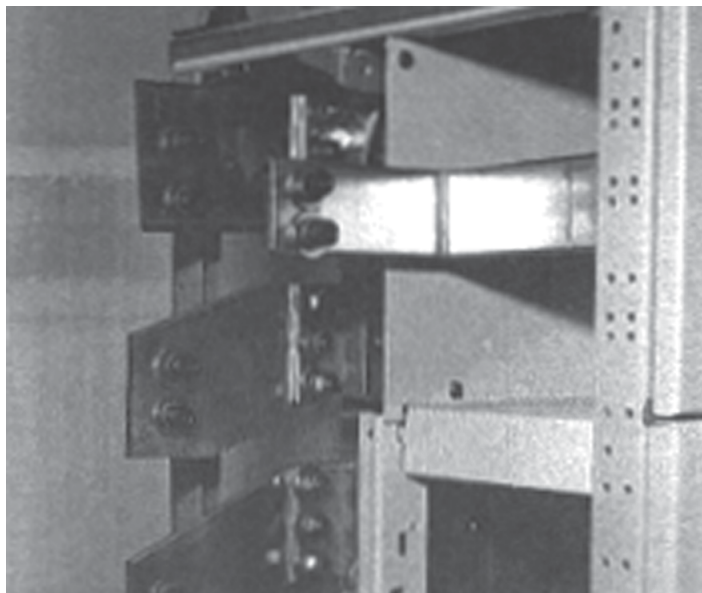

Figure 11. Splice plates attached to Freedom 2100 horizontal bus and ground bus at top

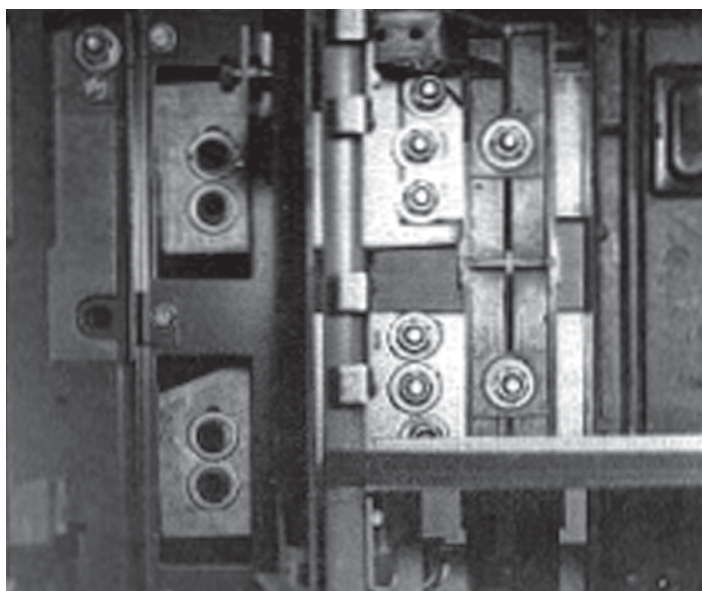

Figure 12. Horizontal bus splice Freedom Unitrol on left, Freedom 2100 on right

Part 4. Installing conduit and wiring

Conduit

Install conduit in such a manner as to prevent water from entering and accumulating in the conduit or the enclosure. Eliminate sags in conduit. Have the conduit enter the motor control center (MCC) in the areas designated for conduit entry on the plan views. See **page 27** and **page 28** of this booklet and outline drawings shipped with the MCC. Keeping conduit within the shaded areas shown in the plan views will avoid cable interference with structural members and live bus. See **Part 12**.

For arc resistant MCCs, use conduit in top or bottom MCC locations as shown on **page 27** and **page 28** of this booklet. Do not alter the front, sides, or back of arc resistant MCCs.

Wiring

Install the line and load conductors sized in accordance with the NEC. **Use copper wire only for control terminations. Use copper wire only for power terminations unless they are marked "CU/AL."** Use conductors with a temperature rating of 167 °F (75 °C) or higher, but regardless of the insulation temperature rating, select the wire size on the basis of 167 °F (75 °C) wire ampacity. Using a higher temperature wire ampacity table often results in a smaller cross-section of copper available for carrying heat away from terminals.

Install insulated wire and cable at a temperature sufficiently warm to prevent the insulation from cracking or splitting.

When more than one conduit is run from a common source or to a common load, be sure to have each conduit carry conductors from each phase and the same number of conductors per phase. If the phase conductors are not distributed uniformly, eddy currents will be generated in the steel between the conduits.

Locate conductors within the MCC to avoid physical damage and to avoid overheating. Secure incoming power lines in a manner adequate to withstand the forces that will act to separate the conductors under short-circuit conditions. Use the cable ties furnished in both horizontal and vertical wireways to support the load and interconnection wire. Use a shielded communications cable inside of flexible metal conduit to protect very low voltage signals transmitted to or from a computer or programmable controller.

Lugs furnished with the MCC and its components are for Class B and Class C stranding. Verify the compatibility of wire size, type, and stranding with the lugs furnished. Where they are not compatible, change the wire or lugs accordingly. If crimp lugs are used, crimp with the tools recommended by the manufacturer.

Use care in stripping insulation to avoid nicking or ringing the metal. All field wiring to control units should be made in accordance with the wiring drawings that are furnished with the control center. Load and control wiring can be brought in through the upper and/or lower horizontal wireways. Determine the type of wiring installed in the control center (NEMA Type B or C) and proceed per the following appropriate paragraph.

The phase sequence of the power circuit load terminals (top-to-bottom: T1, T2, T3) in units mounted on the rear side of the MCC is opposite to that of the load terminals in units mounted on the front side of a back-to-back MCC. To obtain the same direction of rotation for a motor connected to a rear-mounted unit as for one connected to a front-mounted unit, re-label the terminals in the rear-mounted unit: T3, T2, T1, and wire accordingly. Refer to the warning sticker supplied with rear-side units. When making power connections to the starter terminals, be sure to leave sufficient slack in the wires so that the unit can be withdrawn to the detent position for maintenance. See **Table 8**.

NEMA Type B wiring

Each control unit is factory assembled with devices inter-wired within the unit. In addition, all control wiring is carried to unit terminal blocks mounted on the right-hand side of the unit. See **Figure 15**. Bring the field wiring of control wires from a horizontal wireway into the vertical wireway on the right-hand side of the applicable control unit and terminate them at the unit terminal blocks.

Bring load wiring from the vertical wireway, under the bottom right-hand side of the unit, to terminations within the unit. If optional load terminals are provided, terminate load wires to load terminals located adjacent to the vertical wireway. To gain access to these terminals, place tool between right-hand wrapper side and wireway post as shown in **Figure 17**.

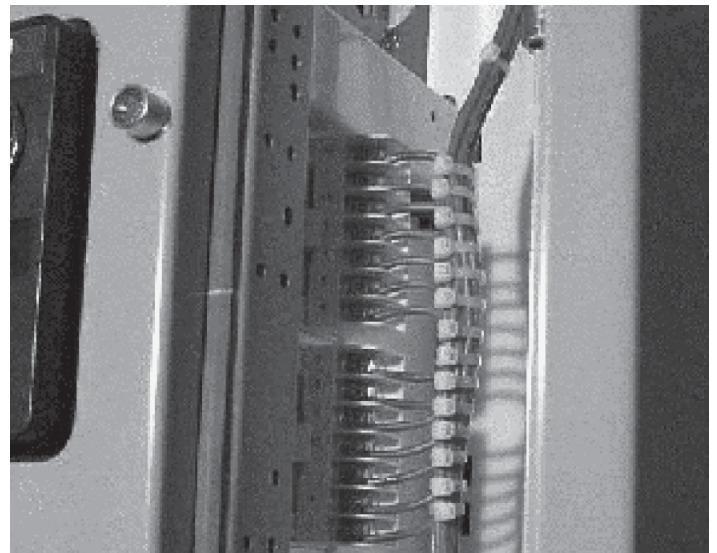

Figure 15. Unit terminal blocks

Engaging pull-apart terminal blocks

The male portion of the pull-apart terminal block is located in a plastic bag tied to the pivot rod inside the unit. This terminal block can be wired outside of the vertical wireway. To engage the terminal block, align the fingers of the male connector with the slot at the back of the female portion of the terminal block. Then rotate the male portion forward and to the left into the female portion of the terminal block. Each male portion of the pull-apart terminal block has two cavities adjacent to the center terminal screw to accept the blade of an electrician's screwdriver used to cam the block into and out of engagement. Each male portion also has a rear slot that can engage the edge of the unit frame where it can be mounted for ease in troubleshooting.



Figure 16. Pull-apart terminal blocks

NEMA Type C wiring

Each control unit is factory assembled with devices inter-wired within the unit. In addition, all control wiring is carried to unit terminal blocks on the side of the unit and from these unit blocks, along with load wiring through Size 3, to master terminal blocks located at the top or bottom of the structure. See **Figure 17**. Master terminal blocks can be either fixed or drawout mounted. In the drawout design, the terminal blocks are rack mounted to permit withdrawal of the entire assembly for ease of wiring during installation and maintenance. Bring field wiring from the horizontal wireway to the master terminal blocks except for load wiring larger than Size 3. These latter load wires should be carried into the vertical wireway and under the bottom right-hand side of the unit to terminations within the unit.



Figure 17. Master terminal block

Part 5. Incoming line connections

Overcurrent protection

All ungrounded conductors in a motor control center (MCC) installation require some form of overcurrent protection in order to comply with Section 240.20 of the NEC. Such overcurrent protection for the incoming lines to the MCC is in the form of fuses or a circuit breaker located at the transformer secondary that supplies the MCC. The conductors from the transformer secondary constitute the feeder to the MCC, and the "10-foot rule" and the "25-foot rule" of NEC, 240.21 apply. These latter exceptions to the general rule allow the disconnect means and overcurrent protection to be located in the MCC, provided the feeder taps from the transformer are sufficiently short and other requirements are met.

A circuit breaker or a circuit interrupter combined with fuses controlling the power to the entire MCC may provide the overcurrent protection required as described above or may be a supplementary disconnect (isolation) means. See **Figure 18**, **Figure 19**, and **Figure 20**.

When the MCC has a main disconnect, bring the incoming lines (the feeders) to the line terminals of the circuit breaker or circuit interrupter. The load side of the circuit breaker or the load side of the fuses associated with the circuit interrupter has already been connected to the MCC bus bar distribution system. In the case of main disconnects rated 400 A or less, this load connection is made by stab connections to vertical bus bars that connect to the horizontal bus distribution system. See **Figure 18**.

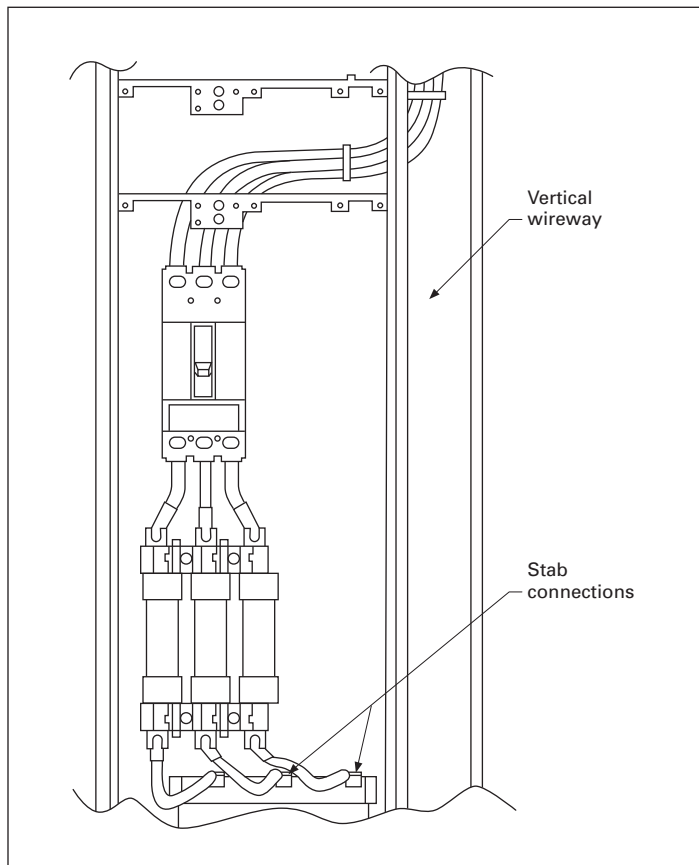

Figure 18. Main disconnect with stab load connections overcurrent protection to be located in the MCC, provided the feeder taps from the transformer are sufficiently short and other requirements are met

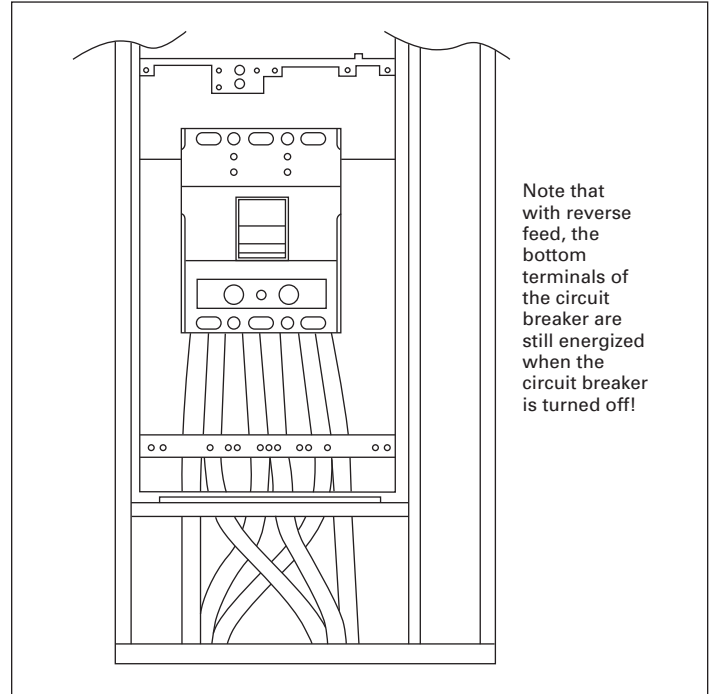

Figure 19. Main circuit breaker with reverse feed

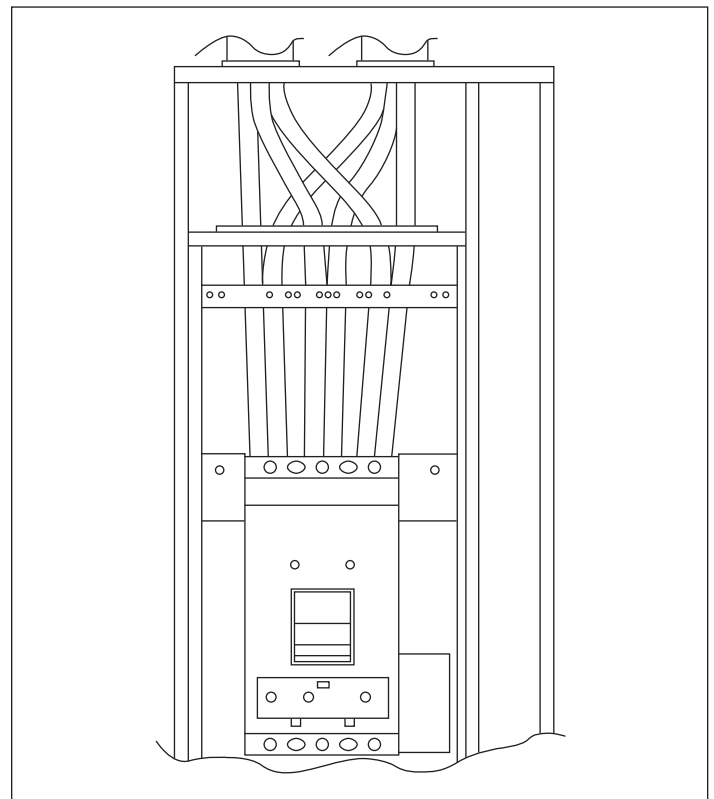

Figure 20. Main circuit breaker

Incoming line lugs

Where the overcurrent protection for the MCC is at a remote location, the MCC feeder lines are connected to incoming line lugs attached to the bus bar distribution system. See **Figure 21**. For high-ampere rated horizontal bus bar systems, the incoming line lugs are mounted on vertical risers that connect to the horizontal bus bars. See **Figure 22**.

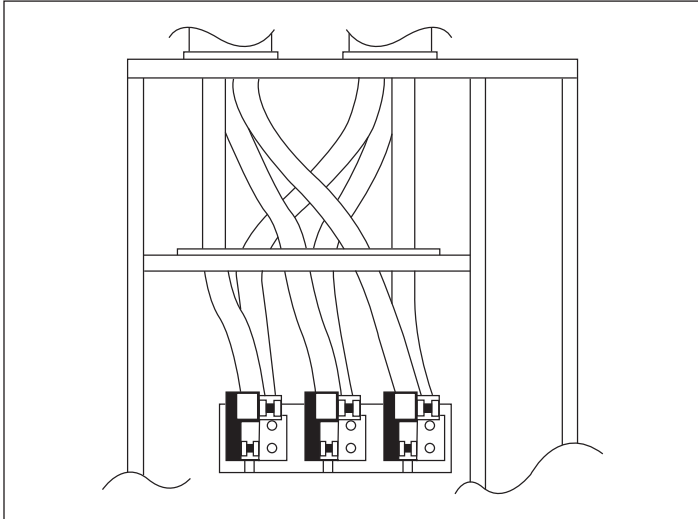

Figure 21. Incoming line lug connections

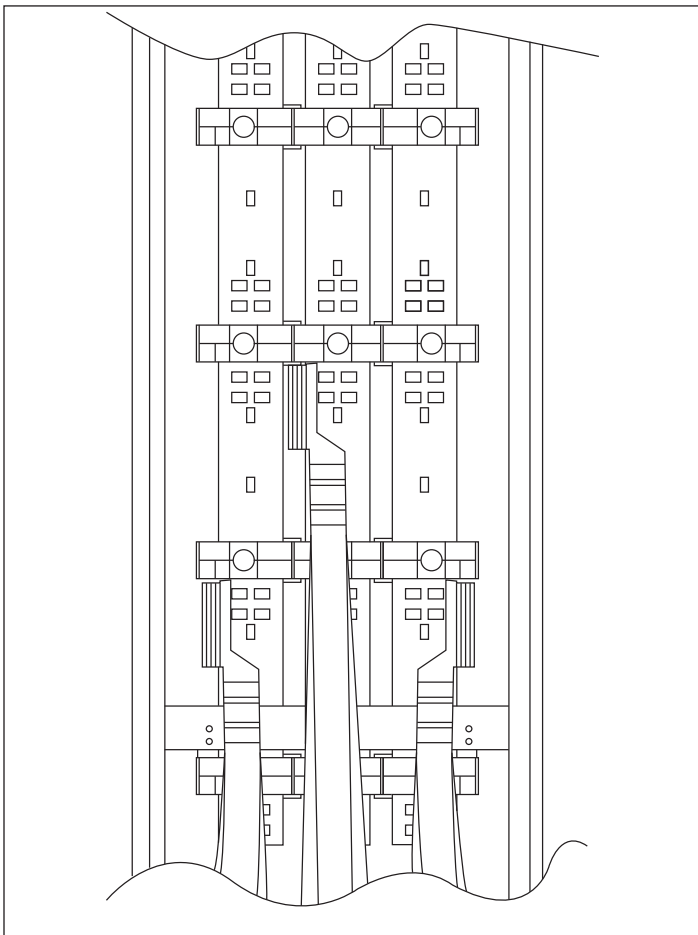

Figure 22. Incoming line compartment, 2000 A

Short-circuit bracing

All incoming lines to either incoming line lugs or to main disconnects must be braced to withstand the mechanical forces created by a high fault current. With the remainder of a Freedom 2100 MCC rated for not less than 65,000 A (rms symmetrical), the installing electrician needs to anchor the cables at the incoming line connections sufficiently and tighten the lugs correctly.

Each incoming line compartment is equipped with two-piece sheet steel brackets that form a cable bracing support bracket that is approximately 9 inches from the conduit entry point, for both top- and bottom-feed applications. Use the bracket and appropriate lashing material to tie the cables securely together if bundled or to hold apart when they are required to be separated. See **Figure 23**, which shows the two-part mounting/bracing bracket, in a top entry incoming lug configuration.

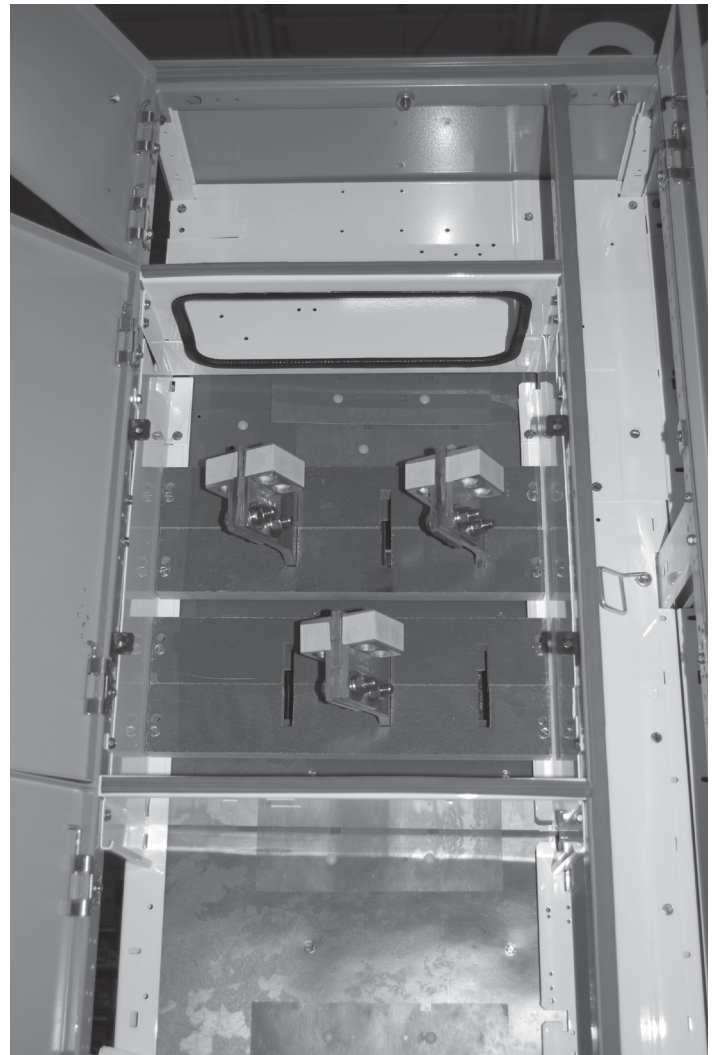

Figure 23. Incoming line compartment showing two-piece support bracket, with opening for cables

Making connection

⚠ CAUTION

ALL INCOMING LINE COMPARTMENTS PRESENT AN OBVIOUS HAZARD WHEN THE DOOR IS OPENED OR COVERS ARE REMOVED WITH POWER ON. WHEN WORKING IN THIS AREA, THE INCOMING FEEDER SHOULD BE DE-ENERGIZED.

Before beginning work on incoming line connections, refer to all drawings furnished by Eaton, as well as all applicable contract drawings for the particular installation.

Depending on the location, size, and type of the incoming arrangement, remove one or more horizontal and vertical wireway doors, and selected units to provide complete access. See **Part 9, page 20** for unit removal instructions.

For top entry, the top cover plates are easily removed for drilling or punching operations.

MCC with a Magnum™ or a main lug only incoming line (Figure 21) section—cable bracing/lashing for top- and bottom-feed arrangements

1. All cable must be terminated with two-hole mounted compression or mechanical set-screw type lugs.
2. All non-current-limiting circuit breakers rated above 42 kA and with circuits rated for 800 A and below require cable lashing per **Figure 24**.
3. Circuit breaker rated 42 kA and below require no cable lashing.
4. No cable lashing is required for current-limiting circuit breakers.
5. No cable lashing is required for circuits using more than four (4) cables of 500 kcmil or larger size wire per phase, regardless of short circuit rating.

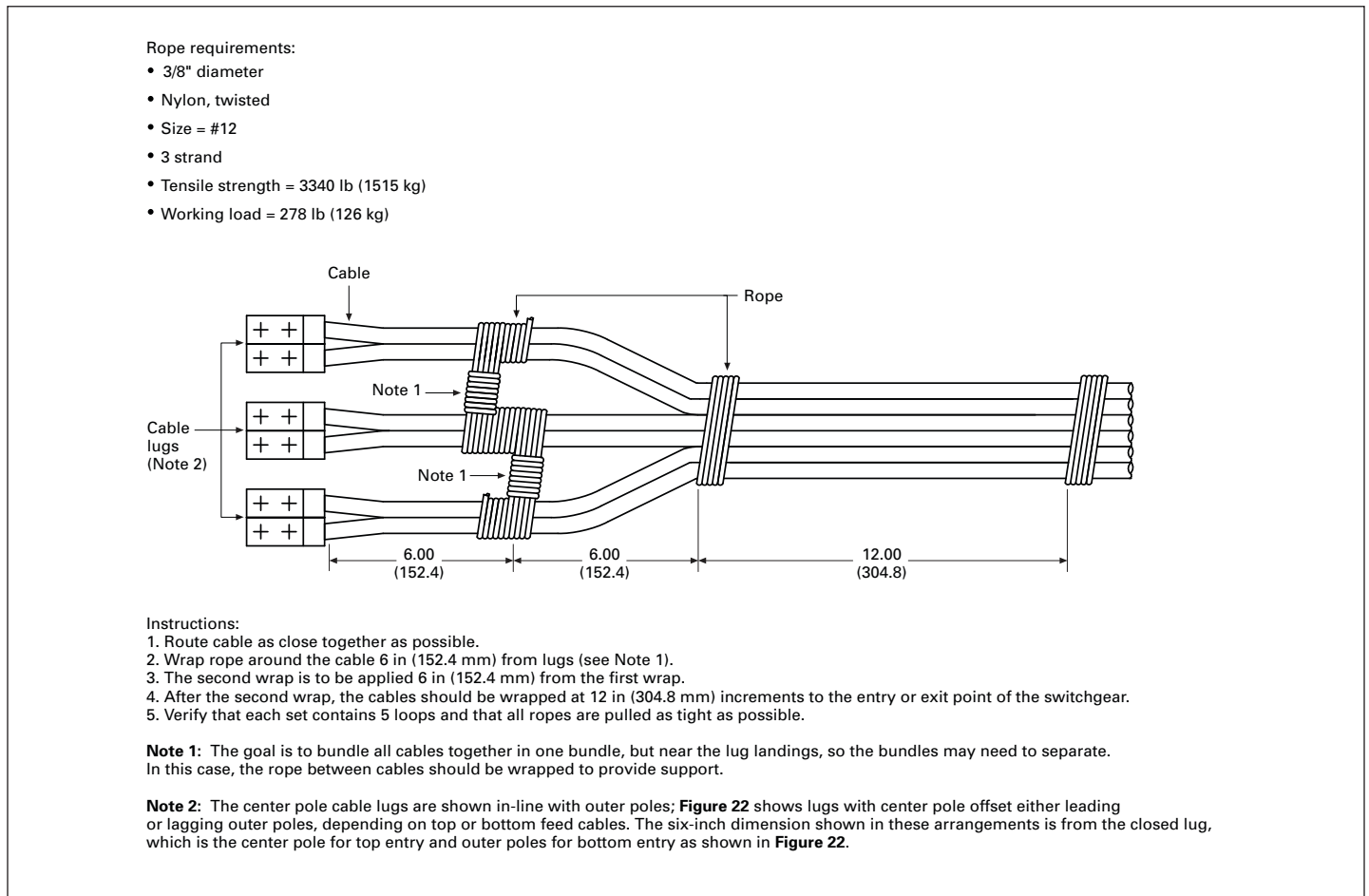

Figure 24. Cable lashing installation instructions

Part 6. Overcurrent protection devices

Device selection

Articles 240 and 430 of the NEC contain the rules for selecting fuses, circuit breakers, and overload relays by type and by voltage and ampere rating. Follow these rules for feeder circuits, and the instructions attached to the inside of the left-most vertical wireway door, for motor branch circuits. Select and install overload relay current elements (heaters) based on the motor service factor and full-load current. Ambient-compensated overload relays are used in motor control centers (MCCs) to offset the temperature gradient that occurs from top to bottom in a loaded vertical section.

Heaters must be installed in the starter overload relay assemblies before the starter is energized.

C306 thermal overload relays (Figure 25)

C306 overload relays are provided on Freedom starters. Four sizes are available for overload protection up to 114 A. Features include:

- Selectable manual or automatic reset operation
- Interchangeable heater packs adjustable $\pm 24\%$ to match motor FLA and calibrated for use with 1.0 and 1.15 service factor motors. Heater packs for 32 A overload relay will mount in 75 A overload relay—useful in derating applications such as jogging
- Class 10 or 20 heater packs (Figure 25). Use Class 10 heaters with fusible or thermal-magnetic breaker disconnects only
- Bimetallic, ambient-compensated operated. Trip-free mechanism
- Electrically isolated NO and NC contacts (pull RESET button to test)
- Overload trip indication
- Single-phase protection
- UL® listed, CSA® certified, and NEMA compliant



Figure 25. C306 thermal overload relay and heater pack

C306 overload relay setting

FLA Dial Adjustment—For motors having a 1.15 service factor, rotate the FLA adjustment dial to correspond to the motor's FLA rating. Estimate the dial position when the motor FLA falls between two letter values as shown in Figure 26.

For motors having a 1.0 service factor, rotate the FLA dial one-half position counterclockwise (CCW).

Manual/Automatic Reset—The overload relay is factory set "M" for manual reset operation as shown in Figure 26. For automatic reset operation, turn the reset adjustment dial to the "A" position. Automatic reset is not intended for two-wire devices.

Test For Trip Indication—To test overload relay for trip indication when in manual reset, pull out the blue reset button. An orange flag will appear indicating that the device has tripped. Push reset button to reset.

⚠ WARNING

TO PROVIDE CONTINUED PROTECTION AGAINST FIRE OR SHOCK HAZARD, THE COMPLETE OVERLOAD RELAY MUST BE REPLACED IF BURNOUT OF THE HEATER ELEMENT OCCURS.

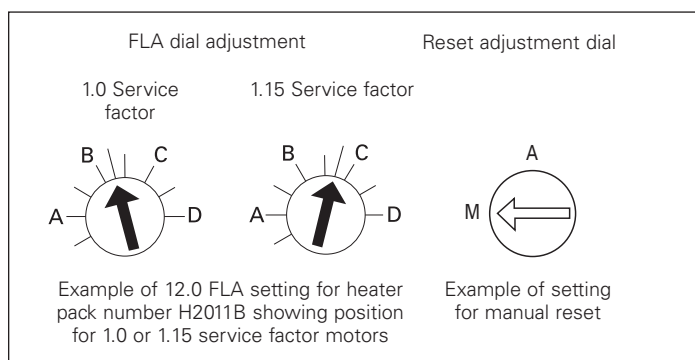

Figure 26. Overload relay settings

Current transformers

When current transformers are used with overload relays, the current through the overload relay heater is related to the motor full-load by the inverse of the current transformer ratio.

⚠ WARNING

DO NOT EVER REMOVE HEATERS FROM SIZE 5 AND LARGER STARTERS TO CHECK UNIT OPERATION. THESE STARTERS USE CURRENT TRANSFORMERS TO DROP THE CURRENT TO THE RANGE OF THE SIZE 1 OVERLOAD RELAY. OPERATION WITH HEATERS REMOVED WILL NOT INTERRUPT VOLTAGE TO THE MOTOR AND WILL GENERATE DANGEROUS VOLTAGES IN THE OPEN SECONDARY OF THE CURRENT TRANSFORMER.

Motor circuit protector (HMCP)

After installation of the control center, each MCP must be adjusted to actual motor full-load amperes (FLA) so that it will trip at any current that exceeds starting inrush. This setting provides low-level fault protection. The first half-cycle inrush will vary with the motor characteristics. Motors with locked-rotor currents of 6 times motor full-load amperes will usually require an instantaneous magnetic setting of 7 to 11 times motor full-load amperes to prevent tripping when starting.

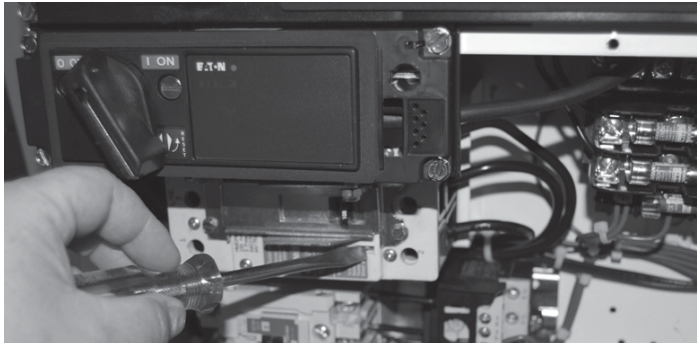

Figure 27. HMCP magnetic adjustment

A cam to accept a small narrow-blade electrician's screwdriver is near the lower left corner and around that are eight lettered adjustment points, calibrated in trip amperes. See **Figure 27**. Adjustment should never exceed 13 times FLA, which is in accordance with NEC requirements for magnetic-trip-only breakers. **Adjustment should be made as follows:**

1. Obtain FLA from motor nameplate.
2. Multiply FLA by 13.
3. Set the cam to the highest trip setting that does not exceed the calculated figure of Item 2. This is the maximum setting that should be used.
4. Depress and turn the screwdriver adjustment counterclockwise one setting at a time, until the breaker trips in starting and then adjust upward one setting position. This will ensure that the circuit will open instantly on any current above the motor inrush, usually 7 to 11 times FLA.

The PUSH-TO-TRIP button checks the tripping function and is used to periodically exercise the breaker operating mechanism. The button is designed to be operated by using a small screwdriver.

Once the breaker has tripped, apply force when moving the unit operating handle from the TRIPPED to the RESET position, which is slightly passed the OFF position

Freedom 2100 MCCs are supplied with Type HMCP motor circuit protectors having an interrupting rating to match the short-circuit withstand rating of the bus bar system. For HMCPs in 225 A, 400 A, and 600 A frame sizes, the magnetic-trip adjustment is set for each pole. A three-pole HMCP has three trip settings to adjust. Place all three poles at the same setting.

Current limiters for use with type HMCP and FD breakers

The addition of the current limiter provides interrupting capacity above the range handled by the HMCP in motor starters or by FD thermal-magnetic feeder breakers.

Each HMCP or FD breaker rated up to 150 A has its own current limiter to provide coordinated protection against faults up to 100,000 A, rms symmetrical.

Built-in trip indicators in each phase immediately show when a fault has blown the current limiter and tripped the circuit breaker. This provides protection against single phasing. **After interrupting a fault, the current limiter will require replacement.** After the fault has been cleared, the current limiter is replaced by the removal of three screws. The breaker can then be reset to provide for subsequent high overcurrent protection.

Type HMCP and FD circuit breakers with terminal end covers

Circuit breakers installed in units connected to 600 V distribution systems require a terminal end cap to be installed on the line side. Replace the terminal end cap when replacing circuit breakers in such units.

Part 7. Overload relay heater selection

Heater selection and installation

Heaters should be selected on the basis of the actual full load current and service factor as shown on the motor nameplate or in the motor manufacturer's published literature.

When motor and overload relay are in the same ambient and the service factor of the motor is 1.15 to 1.25, select heaters and set **FLA** adjustment dial from the heater application table.

If the service factor of the motor is 1.0, or there is no service factor shown, rotate the FLA adjustment dial counterclockwise one-half (1/2) position.

The conductors attached to the terminals of an overload relay act as a heat sink and are a consideration in establishing the current rating of each heater element. To prevent nuisance tripping, which will occur if undersized conductors are used, select the wire size as if the conductors had an insulation temperature rating of 167 °F (75 °C), even if the conductors actually used have a temperature rating higher than 167 °F (75 °C).

Protect heater and starter against short circuits by providing branch circuit protection in accordance with the National Electrical Code.

Note: Before installing heater packs, refer to the motor nameplate for **FLA** (full load amps) and service factor (1.5 or 1.0). Select the heater pack from the proper table on this page.

To install:

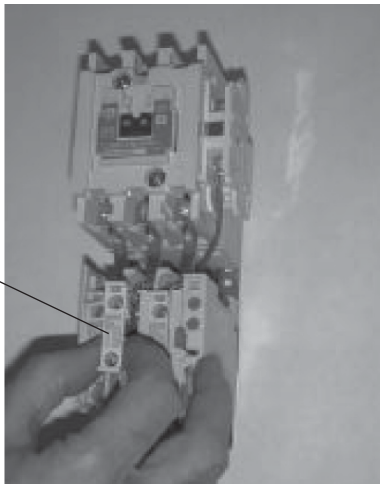

Figure 28. Heater pack

- Insert three (3) identically numbered heater packs into the overload relay with an FLA rating that includes the motor nameplate FLA (full load amps).
- Tighten the heater pack mounting screws securely per recommended torque values listed below.

Heater pack numbers	Recommended torque
H2001B thru H2017B	9 lb-in (1 Nm)
H2018 thru H2024	24-30 lb-in (2.7-3.4 Nm)

- Adjust the FLA adjustment dial to the motor nameplate FLA (full load amps).

The overload is now set for 1.15 service factor.

- If the motor nameplate is 1.0 service factor, rotate the FLA adjustment dial counterclockwise one-half (1/2) position.
- The overload is factory set for **M (MANUAL)** reset operation. If automatic reset is required, turn the reset adjustment dial to **A (AUTO)**. Automatic reset is not intended for two-wire control devices.

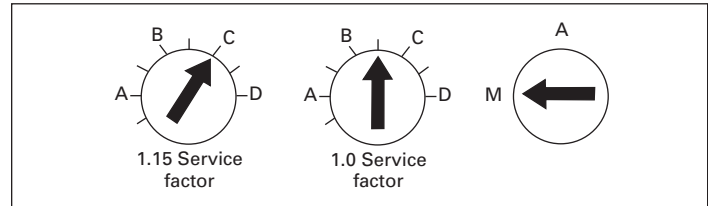

To remove heater packs

Loosen two (2) heater pack mounting screws and remove heater pack from overload relay.

Overload relay setting

This bimetallic ambient-compensated overload relay is adjustable within the FLA range of the heater pack. Each heater pack is marked with its FLA ratings. With proper heater selection, the overload relay will ultimately trip at 125% FLA for a 1.15 service factor motor and at 115% FLA for a 1.0 service factor motor.

Heater selection/installation

Select the appropriate heater pack number that corresponds to the motor FLA rating for your application. Insert each heater into the overload relay and tighten heater mounting screws securely per table below.

Note: A total of three individual heaters must be installed in order for the overload relay to work properly.

Heater pack numbers	Torque
H2001B thru H2017B	9 lb-in
H2018 thru H2024	24-30 lb-in

FLA dial adjustment

For motors having a 1.15 service factor, rotate the FLA adjustment dial to correspond to the motor's FLA rating. Estimate the dial position when the motor FLA falls between two letter values as shown in the example. For motors having 1.0 service factor, rotate the FLA dial one-half (1/2) position counterclockwise (CCW).

FLA	1.0
ADJUSTMENT	SERVICE
DIAL	FACTOR

Example of a 12.0 FLA setting for a heater pack number H2011B showing position for 1.0 or 1.15 service factor motor.

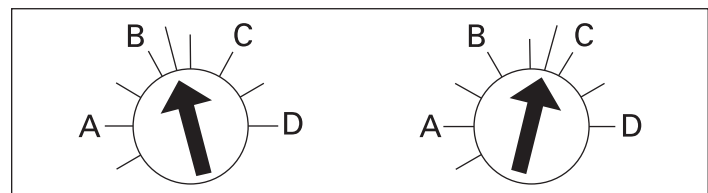

Manual/automatic reset

The overload relay is factory set at “M” for manual reset operation as shown in the illustration. For automatic reset operation, turn the reset adjustment dial to the “A” position. Automatic reset is not intended for two-wire control devices.

RESET
ADJUSTMENT
DIAL

Example of
setting for
manual reset.

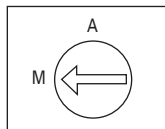

Test for trip indication

To test overload relay for trip indication when in manual reset, pull out the blue Reset button. An orange flag will appear indicating that the device has tripped. Push Reset button in to reset.

For more information, go to www.1800oldunit.com or call 1-800-OLD-UNIT.

Table 1. NEMA Size 0 and 1 heater pack selection table

Motor FLA rating FLA dial positions				Size F standard trip Class 20
A	B	C	D	
0.254	0.306	0.359	0.411	H2001B
0.375	0.452	0.530	0.607	H2002B
0.560	0.676	0.791	0.907	H2003B
0.814	0.983	1.15	1.32	H2004B
1.20	1.45	1.71	1.96	H2005B
1.79	2.16	2.53	2.90	H2006B
2.15	2.60	3.04	3.49	H2007B
3.23	3.90	4.56	5.23	H2008B
4.55	5.50	6.45	7.40	H2009B
6.75	8.17	9.58	11.0	H2010B
9.14	10.8	12.4	14.0	H2011B
14.0	16.9	19.9	22.8	H2012B
18.7	22.7	26.7	30.7	H2013B ①
23.5	28.5	33.5	—	H2014B ①

① After the above referenced settings have been made, rotate the FLA dial one position clockwise for these heaters (see table). If less than one position is available, rotate dial maximum. This does not apply when these heaters are used with adapter base. Catalog No. C306TB1. Exception: does not apply to AN16DNO.

Note: For maximum ratings, see table below. Use 75 °C copper conductors only. Maximum wire size—8 AWG.

NEMA size	Amperes	Size	Amperes
0	18	—	—
1	27	F	32

⚠ WARNING

TO PROVIDE CONTINUED PROTECTION AGAINST FIRE OR SHOCK HAZARD, THE COMPLETE OVERLOAD RELAY MUST BE REPLACED IF BURNOUT OF THE HEATER ELEMENT OCCURS.

Table 2. NEMA Size 2 heater pack selection table

Motor FLA rating ① FLA dial positions				Size J and K standard trip Class 20
A	B	C	D	
3.23	3.90	4.56	5.23	H2008B
4.55	5.50	6.45	7.40	H2009B
6.75	8.17	9.58	11.0	H2010B
9.14	10.8	12.4	14.0	H2011B
14.0	16.9	19.9	22.8	H2012B
18.7	22.7	26.7	30.7	H2013B
23.5	28.5	33.5	38.5	H2014B
29.0	34.0	39.1	44.1	H2015B
39.6	45.5	51.5	57.4	H2016B ②
53.9	60.9	67.9	74.9	H2017B ②

① For motor FLA values not listed, turn the dial clockwise for higher or counterclockwise for lower ratings.

② After the above reference settings have been made, rotate the FLA dial one position clockwise for these heaters (see table). If less than one position is available, rotate dial to maximum. This note does not apply when these heaters are used with adapter base. Catalog No. C306TB1.

Note: For maximum ratings, see table below. Use 167 °F (75 °C) copper conductors only. Maximum wire size—3 AWG.

NEMA size	Amperes	Size	Amperes
2	45	J	60
—	—	K	73

Table 3. NEMA Size 3 and 4 heater pack selection table

Motor FLA rating ① FLA dial positions				Size N standard trip Class 20
A	B	C	D	
18.0	20.2	22.3	24.5	H2018
24.6	27.6	30.5	33.4	H2019
33.5	37.5	41.5	45.6	H2020
45.7	51.2	56.7	62.1	H2021
62.2	69.7	77.1	84.6	H2022
84.7	94.9	105.0	115.0	H2023
106.0	118.0	131.0	144.0	H2024

① For motor FLA values not listed, turn the dial clockwise for higher or counterclockwise for lower ratings.

Note: For maximum ratings, see table below. Minimum wire size—6 AWG.

NEMA size	Amperes	Size	Amperes
3	90	N	14
4	135	—	—

Table 4. NEMA Size 5 heater pack selection table

Motor FLA rating ^① FLA dial positions				Standard trip Class 20
A	B	C	D	
34	41	48	54	H2003B
49	59	69	79	H2004B
72	87	103	118	H2005B
107	130	152	174	H2006B
129	156	182	209	H2007B
194	234	274	—	H2008B

① FLA rating marked on heater pack multiplied by a transformation ratio. For motor FLA values not listed, turn the dial clockwise for higher or counterclockwise for lower ratings.

Note: For maximum ratings, see table below. Minimum wire size—2 AWG.

NEMA size	Amperes
5	270

Table 5. NEMA Size 6 heater pack selection table

Motor FLA rating ^① FLA dial positions				Standard trip Class 20
A	B	C	D	
144	174	205	235	H2005B
215	259	304	348	H2006B
258	312	365	419	H2007B
388	468	547	—	H2008B

① FLA rating marked on heater pack multiplied by a transformation ratio. For motor FLA values not listed, turn the dial clockwise for higher or counterclockwise for lower ratings.

Note: For maximum ratings, see table below.

NEMA size	Amperes
6	540

Table 6. Magnetic reduced-voltage starter classes F600, F700, F890 with C306 thermal overload relay

Starter type	Class	Multiply actual motor full load current by factor below and refer to adjusted full load current column in tables	Quantity of heaters required per starter
Autotransformer	F600	1	3
Part-winding	F700	0.5	6
Star-delta	F800	0.575	3

Part 8. Inspection prior to energizing

- Before energizing the motor control center (MCC), conduct a thorough inspection to make certain that all foreign materials, such as tools, scraps of wire, and other debris, are removed from all units and the structure. Remove any accumulation of dust and dirt with a vacuum cleaner.
- All circuit connections are tightened at time of assembly by power-driven tools with controlled torque. However, the vibrations experienced in transit may loosen some of these connections. Check at least 10% of the total connections for a tight connection. **Should this spot-check reveal some loose connections, it will be necessary to check all connection points.** The connections to be checked include bus hardware, circuit breaker and switch terminals, contactor and relay terminals, and terminal blocks. Always check the incoming line connections. Tighten to the torque values shown in **Table 7**.
- Remove all blocks or other temporary holding means used for shipment from all component devices in the MCC interior.
- Check the enclosure to see that it has not been damaged so as to reduce electrical spacings.
- Compare all circuits for agreement with the wiring diagrams that accompany the MCC. Be sure that each motor is connected to its intended starter.
- Make certain that field wiring is clear of live busses and physically secured to withstand the effects of fault current.
- Check to determine that all grounding connections are made properly.
- Check all devices for damage. Make all necessary repairs or replacements, prior to energizing.
- Manually exercise all switches, circuit breakers, and other operating mechanisms to make certain that they are properly aligned and operate freely.
- Test any ground-fault protection systems that were furnished.
- Set any adjustable current and voltage trip mechanisms to the proper values.
- Ensure that overload relay heater elements are installed and selected to the full-load current shown on the nameplate of each motor.
- Install power circuit fuses in the fusible switches in accordance with NEC application requirements. Make sure that fuses are completely inserted in the clips provided. Do not attempt to defeat the rejection feature on the fuse clip, when provided.
- Do not operate a current transformer with its secondary circuit open. Ensure current transformer is connected to a load, or a secondary shorting bar is installed.
- To prevent possible damage to equipment or injury to personnel, check to ensure that all parts and barriers that may have been removed during wiring and installation have been properly reinstalled.
- Conduct an electrical insulation resistance test to make sure that the MCC and field wiring are free from short circuits and grounds. Do this test phase-to-phase, phase-to-ground, and phase-to-neutral, with the switches or circuit breakers opened.
- If the MCC contains a labyrinth vertical bus barrier system, verify the operation of the automatic shutters. See **Part 9** for adjustments of this mechanism.
- Install covers, close doors, and make certain that no wires are pinched and that all enclosure parts are properly aligned and tightened.
- Turn all circuit breakers and fusible switches to the OFF position before energizing the bus.

Table 7. Driving torque

Description	lb-in
Control wiring	
Coil leads	8 lb-in
Relays	8 lb-in
Pushbuttons	8 lb-in
Control fuse blocks	8 lb-in
Auxiliary contacts	8 lb-in
Control wiring terminal blocks	
Side-mounted lug/compression	9 lb-in
Rail-mounted lug type	12 lb-in
Rail-mounted compression type	18 lb-in

Table 8. Power wiring: starters

For Freedom starters with C306 overload and Freedom contactors	Tightening torque		Conductors
	Wire size (AWG)	Torque (lb-in)	
Size 1 Contactor	20 lb-in		Use 75 °C copper conductors
Size 2 Contactor	14–10	35	
	8	40	
	6–4	45	
	3–2	50	
Size 3 and Freedom Compact Size 4 (CN15MN)	Wire size (AWG)	Torque (lb-in)	
	Slotted head screw		
	8	40	
	6–4	45	
	3–1/0	50	
	Socket head screw		
	Socket size (in)	Torque (lb-in)	
3/16	120		
1/4	200		
5/16	250		
Size 4	275 lb-in		
Size 5	500 lb-in		
Starter with C440 Solid State overload	Wire size (AWG)	Torque (lb-in)	
	NEMA 1 and 2	12-10	23
		8-6	28
NEMA 3	6-1	28	

Table 9. Fused switches

Description	lb-in
30 A fuse assembly	25 lb-in
60 A fuse assembly	50 lb-in
100 A fuse assembly	50 lb-in
200 A fuse assembly	300 lb-in
400 A fuse assembly	300 lb-in
600 A fuse assembly	300 lb-in

Breakers—Refer to torque values on breaker case.

Table 10. Incoming line lugs

Description	lb-in
#2/0–350 kcmil	360 lb-in
#2/0–650 kcmil	360 lb-in
#2/0–750 kcmil	500 lb-in
500–1000 kcmil	600 lb-in

Table 11. Bus bolts

Description	lb-in
All	276 lb-in (23 lb-ft)

Part 9. Unit installation and adjustment

Door removal and installation

All doors on the control center are mounted on pin hinges to facilitate removal for installation and maintenance operations. With the operating handle on the OFF position, rotate the quarter-turn latches, open the door, remove the hinge pins as shown in **Figure 29**, partially close the door and lift it from the structure. Reverse this procedure for installation.

Unit removal and installation

After opening and/or removing the unit door, the control unit is exposed. With a screwdriver, push in on the latch at the top center of the unit and rotate $\frac{1}{4}$ turn counterclockwise.

CAUTION

UNITS 18" OR MORE HIGH HAVE A RETAINING BRACE AT THE LOWER EDGE OF EACH SIDE OF THE UNIT FRAME TO ADD STABILITY IN SHIPPING. THE SHIPPING BRACES MAY BE RETAINED OR REMOVED AFTER INSTALLATION; UNSCREW PRIOR TO UNIT WITHDRAWAL.

CAUTION

FOR ARC RESISTANT MCCS, ENSURE THAT THE REPLACEMENT BUCKET IS MARKED ARC RESISTANT, AS INDICATED BY A YELLOW TRIANGULAR "ARC RESISTANT" LABEL IN THE UNIT.

CAUTION

IF ARC RESISTANT MCC UNITS ARE REMOVED, THEY MUST BE REPLACED WITH THE APPROPRIATE ITEMS SUCH AS ARC RESISTANT SPECIFIC UNIT DOORS, LATCHES, ETC.

Pull-apart terminal blocks in the vertical wireway must be disengaged (see **Figure 30** and **page 10**) and wiring from the unit to other units, to master terminal blocks or to load devices must be disconnected before the unit is removed. Grasp the unit as shown in **Figure 31** and pull it outward. The first inch of travel pulls the stabs free from the vertical bus, and the grounding clip on the side of the unit frame is also disengaged.

To replace a control unit, position the mounting points on the unit frame with the mating guide rails. Slide the unit inward until all four mounting points are engaged, then move it inward with a quick push. This movement easily overcomes the compression of the stabs as they engage the vertical bus. With the unit in its correct position, the quarter-turn latch is easily engaged by pushing inward and rotating $\frac{1}{4}$ turn clockwise.



Figure 29. Hinge pin removal



Figure 30. Disengaging pull-apart terminal blocks

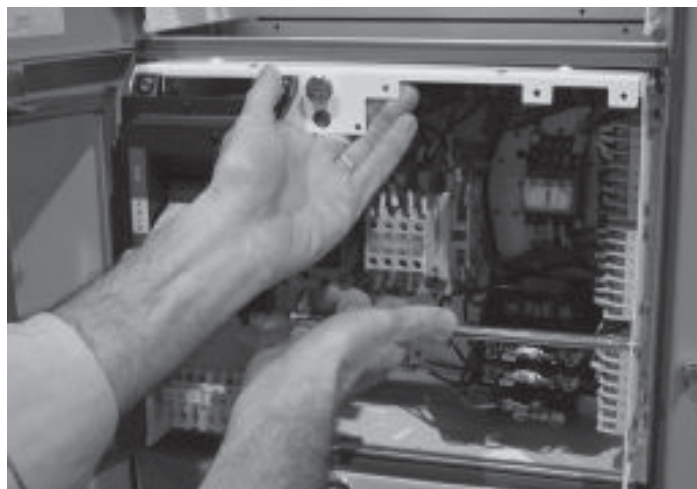

Figure 31. Withdrawing a unit

Detent position

For maintenance and test purposes, the unit can be partially withdrawn (approximately 1 ½ inches) until the stabs are free of the bus. In this position, the quarter-turn latch can be rotated clockwise to engage the detent position slot; this will secure the unit to ensure the stabs remain disengaged during maintenance. See **Figure 32**. The latch can be padlocked in this position.

Operating handle linkage adjustment

Movement of the operating handle in the vertical plane should not be restricted by the handle cavity at either the top or bottom of its travel. Should restriction occur, eliminate it adjusting the length of the operating linkage as shown in **Figure 33**. Depending on the type of primary disconnect device contained in the control unit, it may be necessary to lengthen or shorten the linkage.

Automatic shutter travel adjustment

When the optional labyrinth vertical bus barrier is installed in the control center, a shutter is provided to automatically cover the stab openings when a control unit is withdrawn. The shutter is opened by engagement of the left-hand side of the control unit with the shutter arm linkage attached to the left-hand vertical structural members. When the unit is withdrawn free of the linkage, a spring automatically moves the shutter to its closed position. See **Figure 34** and **Figure 4**.

With the control unit removed, the shutter should completely cover the stab openings. If it does not cover the openings, use an adjustable wrench to bend the link arm to the right until the shutter covers the stab openings.

If, on re-insertion of the control unit, interference is felt between the stab assembly at the rear of the unit and the shutter, the engagement of the control unit with the shutter arm linkage is insufficient to fully open the shutter. Use an adjustable wrench to bend the linkage arm inward toward the unit to increase its engagement with the unit. An inward bend of approximately ¼ inch will provide sufficient additional shutter travel.

Installing pilot devices

The device panel can accommodate up to six pilot devices such as oil-tight pushbuttons, indicating lights, selector switches and miniature meters. If unused space is available and the addition of other devices is desired, observe the following procedure.

After opening the unit door, loosen the two screws at the top of the device panel. Slide the panel ½ inch left to permit it to swing down for access. See **Figure 35**. With the peen end of a ball-peen hammer or with a drift or chisel, remove the desired knockout.

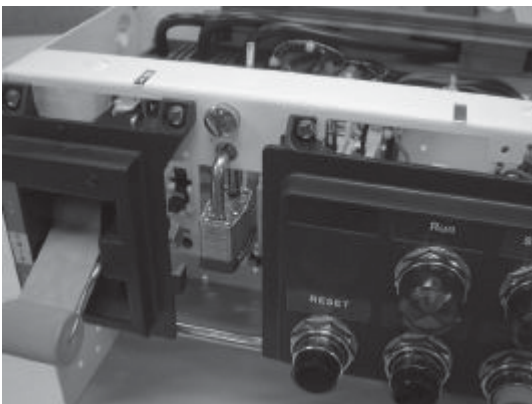

Figure 32. Unit locked in detent position

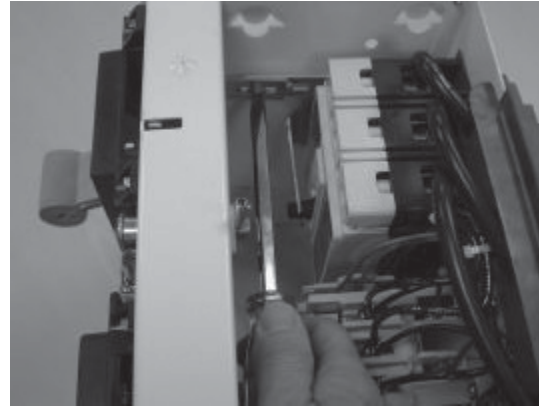

Figure 33. Operating handle linkage adjustment



Figure 34. Shutter arm linkage

CAUTION

BRACE THE PANEL SOLIDLY TO AVOID BREAKING THE HINGE PINTS. USE A KNIFE OR SMALL FILE TO REMOVE REMAINING PLASTID BURRS. INSTALL AND WIRE THE NEW DEVICE AND RE-ATTACH THE TOP OF THE DEVICE PANEL TO THE UNIT.

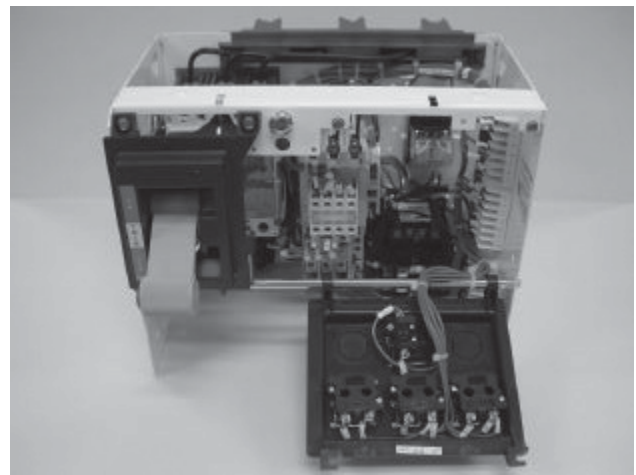

Figure 35. Unit device panel

Installing a new unit

It is recommended that a new unit be installed in a unit space at the top of a vertical compartment or directly below an existing unit. Material provided with the new unit by the factory includes: A divider pan with integral guide rails, a unit door, hinges, catches and hardware. Observe the following sequence of operations for installation.

1. Remove the existing blank door .
2. Position the new unit door over the open space to ensure the hinges and latches are aligned. If the spaces differ, the hinges and latches on the structure must be re-located to match the unit door hinges and latches. Mount the door, using the hinge pins provided.
3. Install the new divider pan in the notches provided in the rear barrier so that it is aligned with the bottom of the new door. Attach the pan to the vertical structure channels with one thread-forming screw on each side.
4. Remove from the vertical bus barrier the flat plate which covers the stab holes that will align with the stabs on the new unit. If an optional labyrinth vertical bus barrier is in place, install an automatic shutter over the stab cutouts. Follow the instruction sheet provided with the shutter kit.

Part 10. Maintenance

Preventive maintenance

Preventive maintenance should be a program, a scheduled periodic action that begins with the installation of the equipment. At that time, specific manufacturer's instruction literature should be consulted, then stored for future reference. Follow-up maintenance should be at regular intervals, as frequently as the severity of duty justifies. Time intervals of one week, or one month, or one year may be appropriate, depending on the duty. It is also desirable to establish specific check lists for each control, as well as a logbook to record the history of incidents. A supply of renewal parts should be obtained and stored.

This control equipment is designed to be installed, operated, and maintained by adequately trained workmen. These instructions do not cover all details, variations, or combinations of the equipment, its storage, delivery, installation, check-out, safe operation, or maintenance. Care must be exercised to comply with local, state, and national regulations, as well as safety practices, for this class of equipment.

Authorized personnel may open a unit door of a motor control center (MCC) while the starter unit is energized. This is accomplished by defeating the mechanical interlock between the operating mechanism and the unit door. A clockwise quarter turn of the slotted head screw located above the operating handle will allow the door to open. See **Figure 36**.

When servicing and adjusting the electrical equipment, refer to the applicable drawings covering the specific motor control center MCC and any other related interconnection drawings. Follow any instructions that may be given for each device. A list of instruction leaflets covering standard components is shown on page 31 of this manual. Any of these leaflets may be obtained by contacting your nearest Eaton representative.

General guidelines—The whole purpose of maintaining electrical equipment can be summarized in two rules:

1. Keep those portions conducting that are intended to be conducting.
2. Keep those portions insulated that are intended to be insulated.

Good conduction requires clean, tight joints, free of contaminants such as dirt and oxides.

Good insulation requires the absence of carbon tracking and the absence of contaminants, such as salt and dust that become hygroscopic and provide an unintended circuit between points of opposite polarity.



Figure 36. Defeater mechanism

⚠ CAUTION

MAINTENANCE OF THE CONTROL COMPONENTS REQUIRES THAT ALL POWER TO THESE COMPONENTS BE TURNED OFF BY OPENING THE BRANCH CIRCUIT DISCONNECT MEANS AND WITHDRAWING THE UNIT TO THE DETENT POSITION (SEE FIGURE 31) OR REMOVING THE UNIT ENTIRELY FROM THE MCC. WHEN UNITS ARE FULLY INSERTED INTO THE MCC, THE LINE SIDE OF EACH DISCONNECT IS ENERGIZED. DO NOT WORK ON FIXED UNITS UNLESS THE MAIN DISCONNECT FOR THE MCC IS OFF.

When working on portions of a branch circuit remote from the MCC, lock the disconnect means for that circuit in the OFF position. To positively lock the operating mechanism in the OFF position, a metal locking bar recessed in the handle may be extended and padlocked with from one to three padlocks. See **Figure 37**.

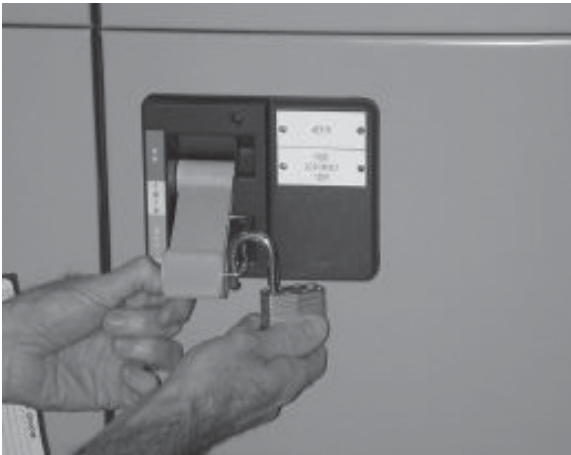

Figure 37. Locking out a disconnect

With the door open and the disconnect device OFF, the operating handle is mechanically interlocked to prevent inadvertently being pushed ON. To defeat this interlock, the bar on the top of the mechanism should be pushed in slightly, allowing the handle to move upward to the ON position.

⚠ WARNING

IF FULLY INSERTED, THE POWER AND CONTROL CIRCUITS WILL BE ENERGIZED. PADLOCKING TO PREVENT THIS HANDLE MOVEMENT MAY BE ACCOMPLISHED BY THE SAME METHOD AS DESCRIBED ABOVE.

Separate control sources of power must also be disconnected. If control power is used during maintenance, take steps to prevent feedback of a hazardous voltage through a control transformer. Be alert to power factor correction capacitors that may be charged. Discharge them before working on any part of the associated power circuit.

Cleaning. Soot, smoke, or stained areas (other than inside arc chutes), or other unusual deposits, should be investigated and the source determined before cleaning is undertaken. Vacuum or wipe clean all exposed surfaces of the control component and the inside of its enclosure. Equipment may be blown clean with compressed air that is dry and free from oil. (Be alert to built-in oilers in factory compressed air lines!) If air blowing techniques are used, remove arc covers from contactors and seal openings to control circuit contacts that are present. It is essential that the foreign debris be removed from the control center, not merely rearranged.

Control equipment should be clean and dry. Remove dust and dirt inside and outside the cabinet without using liquid cleaner. Remove foreign material from the outside top and inside bottom of the enclosure, including hardware and debris, so that future examination will reveal any parts that have fallen off or dropped onto the equipment. If there are liquids spread inside, determine the source and correct by sealing conduit, adding space heaters, or other action as applicable.

Mechanical Checks. Tighten all electrical connections. Look for signs of overheated joints, charred insulation, discolored terminals, and the like. Mechanically clean to a bright finish (don't use emery paper) or replace those terminations that have become discolored. Determine the cause of the loose joint and correct. Be particularly careful with aluminum wire connections. Aluminum wire is best terminated with a crimp type lug that is attached to the control component. When screw type lugs (marked CU/AL) are used with aluminum wire, the joint should be checked for tightness every 200 operations of the device.

Wires and cables should be examined to eliminate any chafing against metal edges caused by vibration, that could progress to an insulation failure. Any temporary wiring should be removed or permanently secured and diagrams marked accordingly.

The intended movement of mechanical parts, such as the armature and contacts of electromechanical contactors, and mechanical interlocks should be checked for freedom of motion and functional operation.

Wrap-up. Check all indicating lamps, mechanical flags, doors, latches, and similar auxiliaries and repair, if required.

Log changes and observations into record book before returning equipment into service. Do not remove any labels or nameplates. Restore any that are damaged.

Contact wear and replacement

Contactors are subject to both mechanical and electrical wear during their operation. In most cases, mechanical wear is insignificant. The erosion of the contacts is due to electrical wear. During arcing, material from each contact is vaporized and blown away from the useful contacting surface.

A critical examination of the appearance of the contact surfaces and a measurement of the remaining contact over-travel will give the user the information required to get the maximum contact life.

Over-travel measurement

Contact life has ended when the over-travel of the contacts has been reduced to 0.02 inch.

Over-travel of the contact assembly is that part of the stroke that the moving contacts would travel after touching the fixed contacts if they were not blocked from movement by the fixed contacts.

A method of measuring over-travel is as follows:

- A. Place a 0.02-inch feeler gauge between the armature and magnet, with the armature held tightly against the magnet.
- B. Check continually in each phase, i.e., determine if circuit from terminal-to-terminal for each pole is open under these conditions.
- C. If there is continuity through all phases, the remaining over-travel is sufficient. If there is not continuity through all phases, replace all stationary and moving contacts plus moving contact over-travel springs. After replacing parts, manually operate contactor to be sure binding does not occur.

Table 12. Contactor troubleshooting chart

Defect	Cause	Remedy
Short contact life	Low contact force	Adjust over-travel, replace contacts, and replace contact springs as required to correct contact force.
	Contact bounce on opening or closing	Correct improper voltage applied to coil. Correct any mechanical defects or misalignment.
	Abrasive dust on contacts	Do not use emery cloth to dress contacts.
	Load current is too high	Reduce load. Use larger contactor.
	Jogging cycle is too severe	Reduce jogging cycle. Check factory for more durable contact material. Use larger contactor.
Overheating	Load current too high	Install arc box.
	Loose connections	Replace broken or eroded insulating parts, arc horns, and grid plates. Clean or replace insulating parts having a heavy coating of foreign conducting material.
	Over-travel and/or contact force too low	Remove contaminating materials that may have accumulated on arc horns and steel-grid plates.
	Ambient temperature is too high	Reduce load. Provide better ventilation. Relocate starter. Use larger contactor.
	Line and/or load cables are too small	Install terminal block and run larger conductors between contactor and terminal block.
Welding of contacts	Over-travel and/or contact force is too low	Adjust over-travel, replace contacts, and replace contact springs as required to correct contact force.
	Magnet armature stalls or hesitates at contact touch point	Correct low voltage at coil terminals as coil draws inrush current.
	Contact drops open to contact-touch position because of voltage dip	Maintain voltage at coil terminals. Install low voltage protective device, sometimes called "Brownout Protector."
	Excessive contact bounce on closing	Correct coil overvoltage condition.

Maintenance of motor controllers after a fault

Note: Reproduced by permission of the National Electrical Manufacturers Association from NEMA Standards Publication No. ICS2-2000 (R2005), Industrial Control Devices, Controllers and Assemblies, copyright 2000 by NEMA.

In a motor branch circuit that has been properly installed, coordinated, and in service prior to the fault, opening of the branch-circuit short-circuit protective device (fuse, circuit breaker, motor short-circuit protector, and so on) indicates a fault condition in excess of operating overload. This fault condition must be corrected and the necessary repair or replacements made before re-energizing the branch circuit.

It is recommended that the following general procedures be observed by qualified personnel in the inspection and repair of the motor controller involved in the fault.

Procedure

CAUTION

ALL INSPECTIONS AND TESTS ARE TO BE MADE ON CONTROLLERS AND EQUIPMENT THAT ARE DE-ENERGIZED, DISCONNECTED, AND ISOLATED SO THAT ACCIDENTAL CONTACT CANNOT BE MADE WITH LIVE PARTS AND SO THAT ALL PLANT SAFETY PROCEDURES WILL BE OBSERVED.

Enclosure. Substantial damage to the unit door or frame, such as deformation, displacement of parts, or burning, requires replacement of the entire unit.

Circuit breaker. Examine the unit interior and the circuit breaker for evidence of possible damage. If evidence of damage is not apparent, the breaker may be reset and turned ON. If it is suspected that the circuit breaker has opened several short-circuit faults or if signs of circuit breaker deterioration appear within the enclosure, the circuit breaker should be replaced.

Disconnect switch. The external operating handle of the disconnect switch must be capable of opening the switch. If the handle fails to open the switch or if visual inspection after opening indicates deterioration beyond normal wear and tear, such as overheating, contact blade, or jaw pitting, insulation breakage or charring, the switch must be replaced.

Fuse holders. Deterioration of fuse holders or their insulating mounts requires their replacement.

Terminals and internal conductors. Indications of arcing damage and/or overheating, such as discoloration and melting of insulation, require the replacement of damaged parts.

Contactors. Contacts showing heat damage, displacement of metal, or loss of adequate wear allowance require replacement of the contacts and the contact springs. If deterioration extends beyond the contacts, such as binding in the guides or evidence of insulation damage, the damaged parts or the entire contactor must be replaced.

Overload relays. If burnout of the current element of an overload relay has occurred, the complete overload relay must be replaced. Any indication that an arc has struck and/or any indication of burning of the insulation of the overload relay also requires replacement of the overload relay.

If there is no visual indication of damage that would require replacement of the overload relay, the relay must be electrically or mechanically tripped to verify the proper functioning of the overload relay contact(s).

Return to service. Before returning the controller to service, checks must be made for the tightness of electrical connections and for the absence of short circuits, grounds, and leakage.

All equipment enclosures must be closed and secured before the branch circuit is energized.

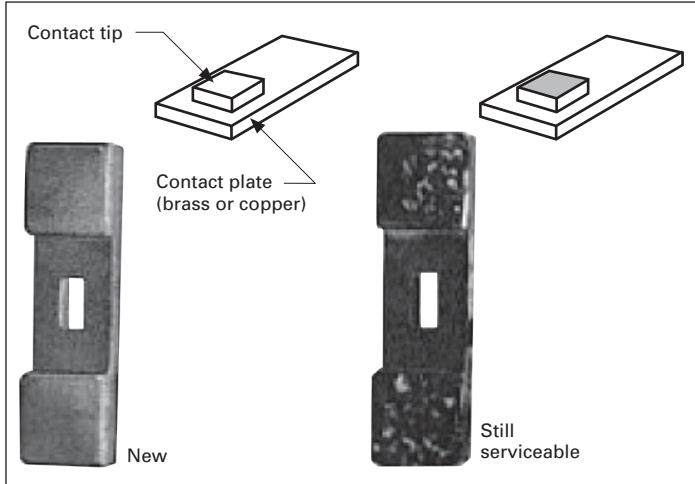

Figure 38. Normal service wear

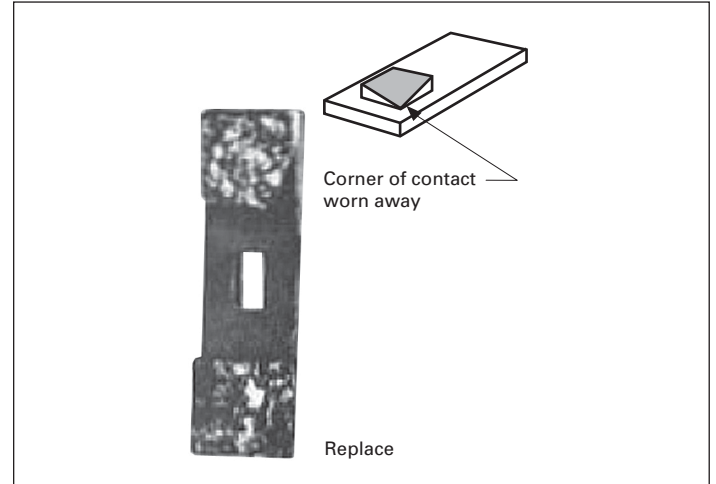

Figure 39. End of service life

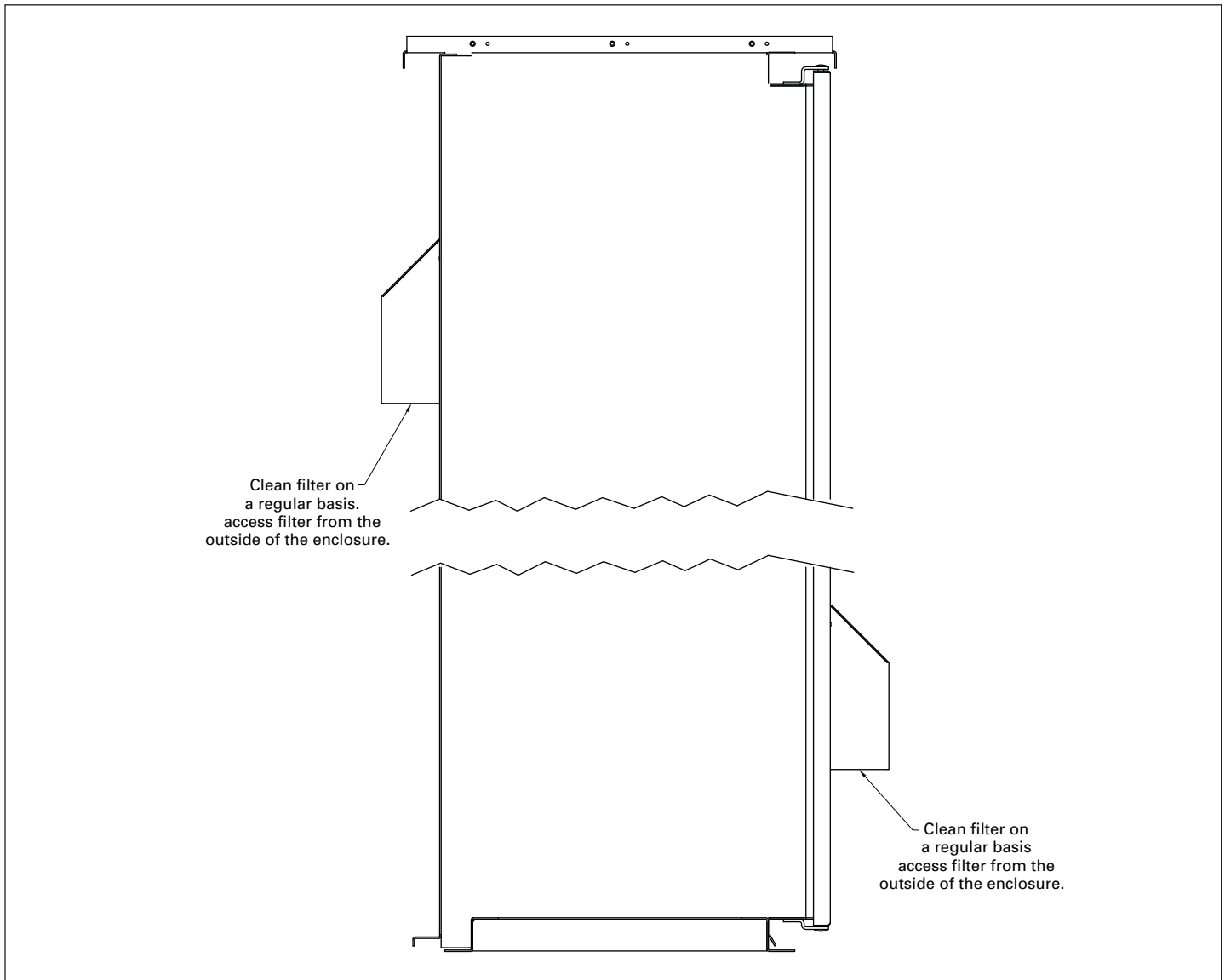

Figure 40. NEMA 3R MCC— all filters require cleaning on regular basis

Table 13. Renewal contact kits, coils, and overload relays

Description	Coil suffix	Part number				
		NEMA Size 1 Series B1	NEMA Size 2 Series B1	NEMA Size 3	NEMA Size 4	NEMA Size 5 Series B1
Renewal parts publication		22177	22177	20426	20428	20429
Contact kits						
Two-pole		6-65	6-65-7	6-43-5	6-44	6-45
Three-pole		6-65-2	6-65-8	6-43-6	6-44-2	6-45-2
Four-pole		6-65-9	6-65-15	—	—	—
Five-pole		6-65-10	6-65-16	—	—	—
Magnet coils						
120 V, 60 Hz or 110 V, 50 Hz	A	9-2703-1	9-2703-1	9-2756-1	9-1891-1	9-1891-1
240 V, 60 Hz or 220 V, 50 Hz	B	9-2703-2	9-2703-2	9-2756-2	9-1891-2	9-1891-2
480 V, 60 Hz or 440 V, 50 Hz	C	9-2703-3	9-2703-3	9-2756-3	9-1891-3	9-1891-3
600 V, 60 Hz or 550 V, 50 Hz	D	9-2703-4	9-2703-4	9-2756-4	9-1891-4	9-1891-4
208 V, 60 Hz	E	9-2703-9	9-2703-9	9-2756-5	9-1891-13	9-1891-13
277 V, 60 Hz	H	9-2703-7	9-2703-7	9-2756-9	9-1891-26	9-1891-26
208/240 V, 60 Hz	J	—	—	—	—	—
240 V, 50 Hz	K	9-2703-14	9-2703-14	9-2756-13	9-1891-20	9-1891-20
380–415 V, 50 Hz	L	9-2703-8	9-2703-8	—	—	—
380 V, 50 Hz	L	—	—	9-2756-12	9-1891-14	9-1891-14
415 V, 50 Hz	M	—	—	9-2756-8	9-1891-21	9-1891-21
550 V, 50 Hz	N	—	—	9-2756-14	9-1891-8	9-1891-8
Overload relays For replacement on existing starters three-pole— ambient-compensated bimetallic		C306GN3B	C306GN3B	C306KN3	C306NN3	C306DN3B

Table 14. Starter type

Description	Unit catalog number designation (class)		
	Disconnect means		
	Fusible	Circuit breaker	Circuit breaker with current limiter
Full voltage, non-reversing	F204	F206	F207
Full voltage, reversing	F214	F216	F217
Reduced voltage, autotransformer type	F604	F606	F607
Reduced voltage, part-winding type	F704	F706	F707
Reduced voltage, closed transition star-delta	F894	F896	F897
Full voltage, non-reversing, two-speed, two windings	F954	F956	F957
Full voltage, non-reversing, two-speed, one winding	F944	F946	F947

Part 11. Plan views

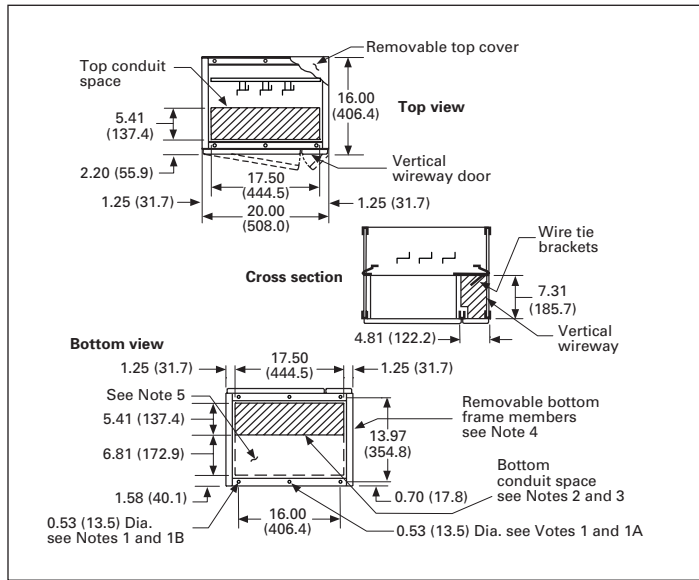

Figure 41. 20 inches wide, 16 inches deep, front mounted only (4710A30)

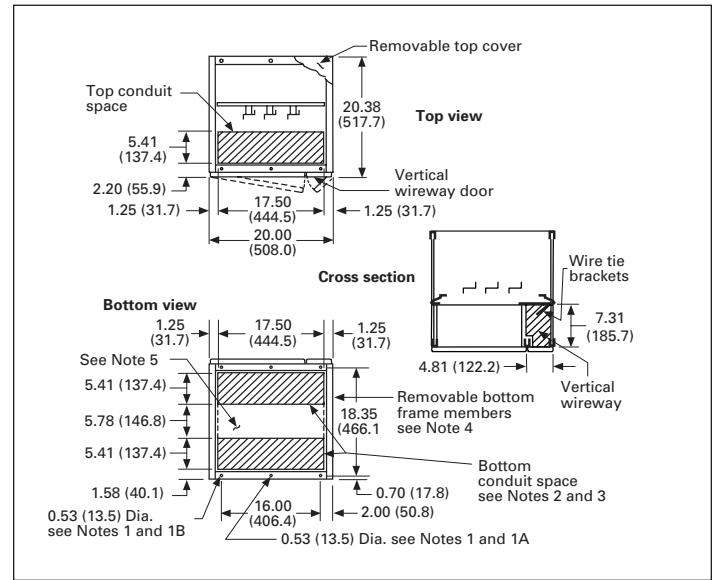

Figure 43. 20 inches wide, 21 inches deep, front mounted only (4710A31)

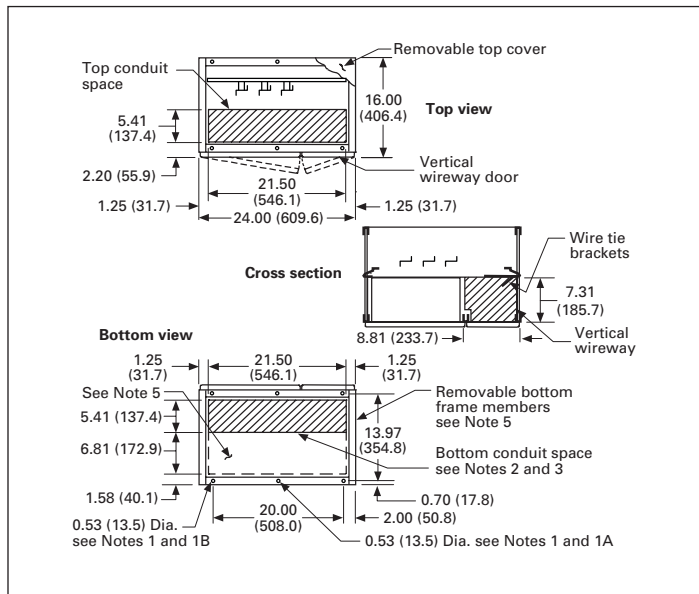

Figure 42. 24 inches wide, 16 inches deep, front mounted only (4710A33)

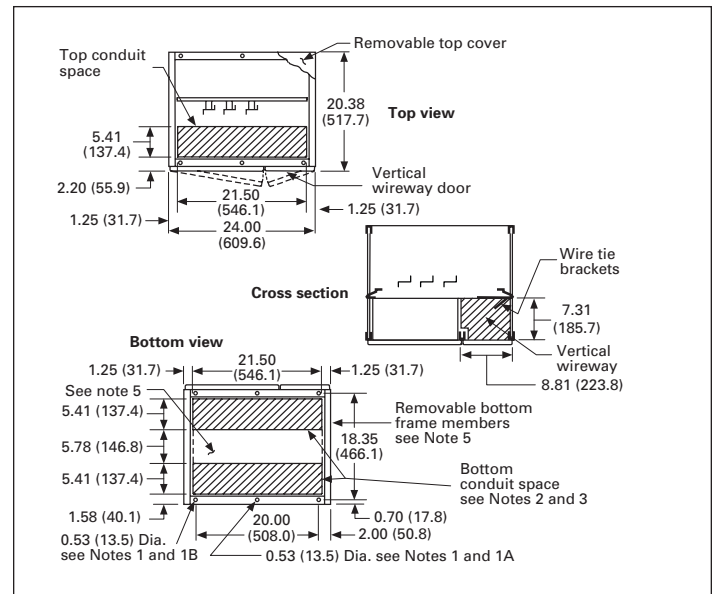

Figure 44. 24 inches wide, 21 inches deep, front mounted only (4710A34)

Notes:

1. Minimum length of anchor bolt is 2.00 (50.8) (0.38-16 grade 5 torqued at 31 lb-ft).
 - A. For non-seismic, mount with two center bolts per enclosure.
 - B. For seismic, mount with minimum four corner bolts per enclosure.
2. Recommended maximum conduit height above floor line is 3.50 inches (88.9 mm).
3. Maximum conduit space with channel sills is 17.50 x 9.73 inches (444.5 x 247.1 mm).
4. For multiple structure assemblies, either one or both of these members is removed to provide maximum unrestricted conduit space at the bottom of the MCC.
5. This conduit space is not recommended when a neutral bus and/or a space heater is required. Otherwise this space is available for conduit. See **Figure 47** for vertical dimensions.

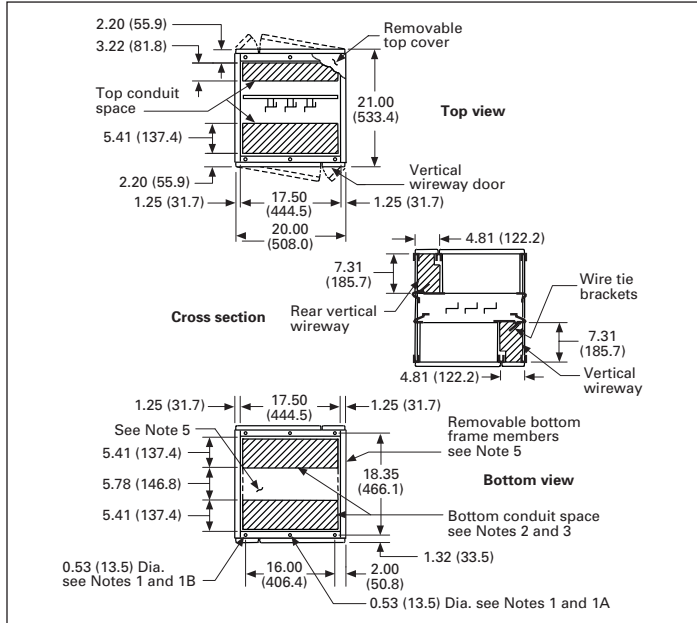

Figure 45. 20 inches wide, 21 inches deep, front and rear mounted (4710A32)

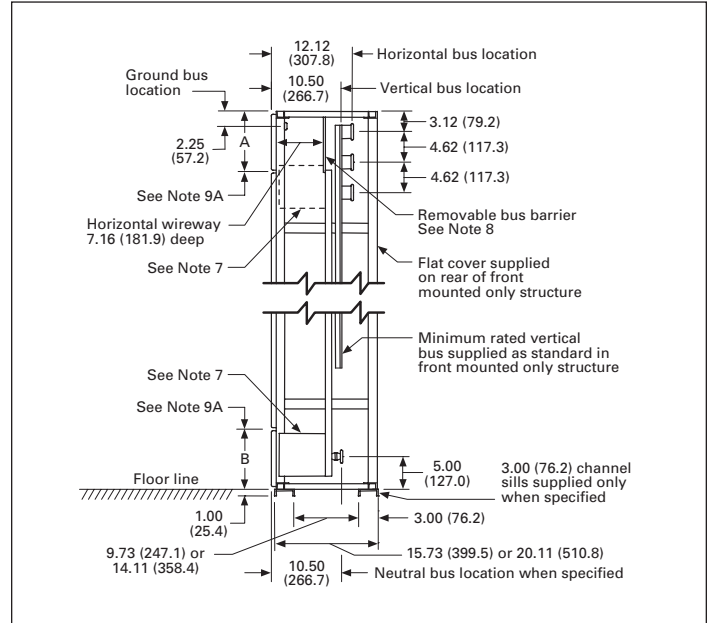

Figure 47. Side View A

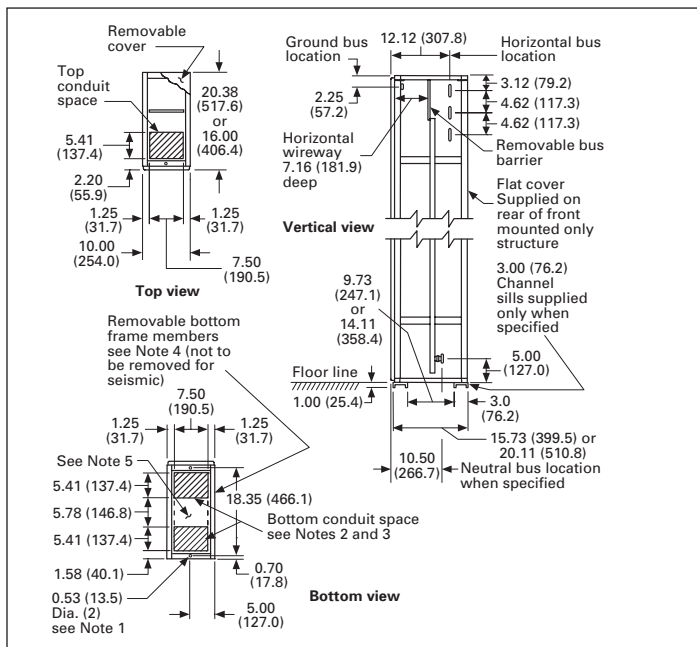

Figure 46. 10 inches wide, 16 or 21 inches deep, transition structure (4710A35/6)

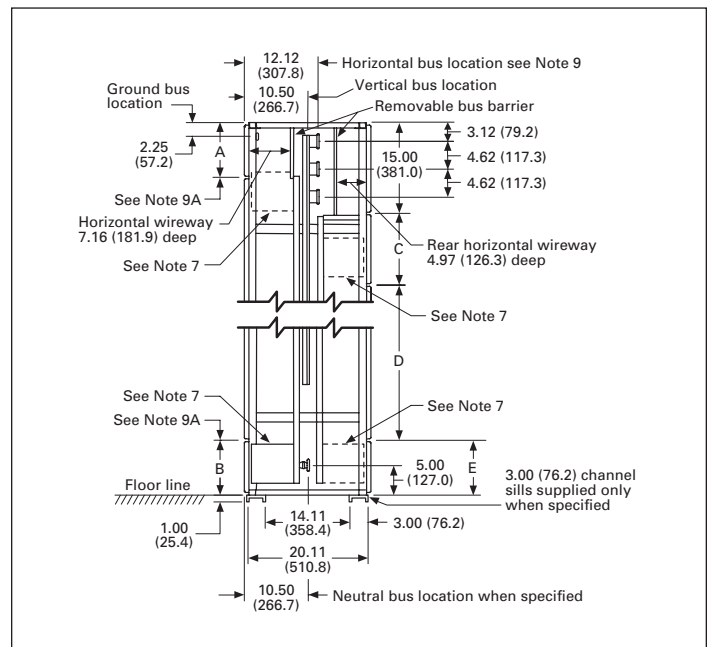

Figure 48. Side View B

Notes:

- Minimum length of anchor bolt is 2.00 (50.8) (0.38-16 grade 5 torqued at 31 lb-ft).
A. For non-seismic, mount with two center bolts per enclosure.
B. For seismic, mount with minimum four corner bolts per enclosure.
- Recommended maximum conduit height above floor line is 3.50 inches (88.9 mm).
- Maximum conduit space with channel sills is 17.50 x 9.73 inches (444.5 x 247.1 mm).
- For multiple structure assemblies, either one or both of these members is removed to provide maximum unrestricted conduit space at the bottom of the MCC.
- This conduit space is not recommended when a neutral bus and/or a space heater is required. Otherwise, this space is available for conduit. See **Figure 48** for vertical dimensions.

- Master Terminal Block (MTB) assembly is furnished for Type C wiring only when location not specified. MTB supplied at the bottom.
- Rear horizontal bus barrier not supplied with front mounted only structure.
- Standard structure arrangement:
A. In front
Without MTB: A and B = 9.00 (228.6 mm)
With MTB at bottom: A and B = 9.00 (228.6 mm)
With MTB at top: A and B = 3.00 (76.2 mm)
B. In rear
Without MTB: C = 0, D = 72 (1828.8 mm), E = 3.00 (76.2 mm)
With MTB at bottom: C = 0, D = 66.00 (1676.4 mm), E = 9.00 (228.6 mm)
With MTB at top: C = 12, D = 60 (1524.0 mm), E = 3.00 (76.2 mm)

Part 12. Related instructional leaflets

Publication	Publication No.
Starters	
Size 5, non-reversing and reversing, vacuum	IL17087
Contactors	
Size 5, non-reversing and reversing, vacuum	IL16999
Size 5, non-reversing and reversing, vacuum	IL17088
Circuit Breakers	
Magnum DS	I.B. 2C12060H08
RotoTract remote racking operating manual	IL04300001E
Series C, F-Frame	IL01219018E
Series C, F-Frame	IL29C101
Series C, J-Frame	IL01204004E
Series C, J-Frame	IL29C103
Series C, K-Frame	IL29C104C
Series C, L-Frame	IL01207002E
Series C, L-Frame	IL29C105
Series C, N-Frame	IL01209003E
Series C, N-Frame	IL29C106
Series C, R-Frame	IL29C613B
Series C, R-Frame	IL29C107
Series G, EG-Frame	IL29C515C
Series G, JG-Frame	IL01207009E
Series G, LG-Frame	IL01207001E
Transfer switches	IL14477

Part 13. Arc resistant LV MCC

General information

LV motor control center (MCC) testing guides have been established for equipment to be tested for the resistance to the effects of an arcing event due to an internal electrical arcing fault.

The Eaton LV MCC has been successfully tested in accordance with IEEE® C37.20.7 and CSA 22.2 No. 0.22-11. The following section of this manual covers the new Eaton Series 2100 arc resistant motor control center.

The overall construction of the new arc resistant LV MCC has been enhanced with structure robustness improvements to contain the dangerous effects of an internal electrical arcing fault event.

Arc resistant ratings nameplate

This rating plate states specifically the arc resistant rating per the IEEE C37.20.7 and CSA 22.2 No. 0.22-11 as follows:

- MCC accessibility type
- Internal arcing fault kA
- Arc duration—either device limited or a duration time
- Type of protective device—either NGH or RGH if specially stated as a device limited product

WARNING

**ALL DOORS MUST BE CLOSED AND LATCHED AND ALL COVERS IN PLACE AND SECURED PRIOR TO ENERGIZING MCC.
MCC IS ONLY ARC RESISTANT WHEN ALL DOORS AND COVERS ARE CLOSED AND PROPERLY SECURED PRIOR TO ENERGIZING MCC.
FAILURE TO CLOSE AND SECURE MCC PER GUIDELINES COULD RESULT IN SEVERE INJURY OR DEATH.
THE ARC RESISTANT RATING IS ONLY VALID WHEN ALL DOORS ARE CLOSED AND PROPERLY LATCHED OR BOLTED, AND ALL COMPONENTS ARE INSTALLED AND WORKING PROPERLY.
IN ADDITION, REMOVAL OF ANY MCC UNIT/BUCKET FROM ITS CELL WITHOUT REINSTALLING A UNIT/BUCKET OR ARC RESISTANT FUTURE SPACE INNER COVER AND DOOR WILL VOID THE ARC RESISTANT RATING.
VERIFY THAT THE DOOR AND COVER ARE SECURE PRIOR TO ENERGIZING THE ARC RESISTANT LV MCC.**

Accessibility

Note: If an installed MCC is wall mounted or has access that is less than 3 feet wide to a wall on the MCC sides and rear, the TYPE 2 accessibility rating defaults to TYPE 1. A Type 2 accessibility rating must have full OSHA and NFPA access clearance of 3 feet minimum.



Figure 49. Arc resistant LV MCC—wireway doors and labeling



Figure 50. MCC unit and vertical wireway door latches and hinges

The arc resistant MCC lineup left and right end sections are special 4-inch wide arc resistant chambers with permanent front covers. These chambers absorb the high pressure shock wave produced by an arcing event.

⚠ WARNING

DO NOT REMOVE OR ALTER THESE ARC RESISTANT END CHAMBERS. THE ARC RESISTANT RATING IS ONLY VALID WHEN THE MCC LINEUP IS COMPLETELY INSTALLED WITH THE ARC RESISTANT CHAMBERS IN PLACE ON BOTH ENDS OF THE MCC LINEUP.

⚠ WARNING

ONLY INSTALL CLEARLY MARKED UNITS (BUCKETS) WITH "ARC RESISTANT" LABEL IN FUTURE SPACES, USING INSTRUCTION MANUAL 50-41929.

Install "U" clamps in the positions as shipped. MCC frames are clamped together with four "U" clamps (4700A48H01) in the front. MCC frames are clamped together with five "U" clamps (4700A48H01) in the rear. There is one extra-long frame clamp at the rear behind the horizontal bus (79-23866). If the MCC has limited rear access, as with a bolted back-to-back MCC line, only install the very bottom clamp and extra-long top clamp.

In cases where the "U" clamp will not fit in the front, e.g., multiple 1X units, a 839A681H08 screw may be used in the normal "U" clamp position. The screw should be installed from the left structure wireway through the cornerpost into the adjacent structure cornerpost leftmost flange.



Figure 51. Arc resistant MCC lineup

Table 15. Arc resistant MCC door hinge, latch, and hardware configurations

Door arrangement	Hinges	Latches	Bolted (¼-20)
Top wireway door	2	0	1
Bottom wireway door	0	0	2
Vertical wireway door	3	3	0
MLO door	7	0	7
JG feeder 1X door	0	0	4
Dual feeder 2X door	2	0	4
LG feeder 4X door	4	0	4
RG/NG main 72-inch doors	7	0	7
6-inch unit 1X door	1	2	0
12-inch unit 2X door	2	2	0
18-inch unit 3X door	3	3	0
24-inch unit 4X door	4	4	0
30-inch unit 5X door	5	5	0
36-inch unit 6X door	6	6	0
42-inch unit 7X door	6	6	0
48-inch unit 8X door	6	6	0
54-inch unit 9X door	6	6	0
60-inch unit 10X door	6	6	0
66-inch unit 11X door	6	6	0
72-inch unit 12X door	7	7	0
TP1 transformer door 7X	6	0	6
TP1 transformer door 8X	6	0	6
20-inch wide relay panel door 12X	7	0	7
24-inch wide relay panel door 12X	7	0	7
28-inch wide relay panel door 12X	7	0	7
32-inch wide relay panel door 12X	7	0	7

Note: Contact your local Eaton representative if additional information is required.

Part 14. Contacting Eaton

Eaton understands that you have a choice in your selection of electrical products and that your expectation is that we continue to strive toward perfection in our product quality and service to you. If you require assistance, the numbers listed are available in addition to your local Eaton sales engineer or authorized distributor.

Engineering & Service: Eaton.com/Service
(800) 498-2678

Warranty Assistance: Eaton.com/Eatoncare
(800) 544-6691

Replacement Parts: Eaton.com/MCCAftermarket
(800) 653-8648

For the fastest resolution, please provide the following information when contacting Eaton.

- 1. General Order # (see master nameplate on first structure)**
- 2. MFG Date (see master nameplate on first structure)**
- 3. Description of the issue/problem**
- 4. Location in assembly (e.g., unit 2D)**
- 5. Type of application**
- 6. Your phone #'s, shipping address, email, contact name, and name of company**



Scan the QR code for more information.

Eaton
1000 Eaton Boulevard
Cleveland, OH 44122
United States
Eaton.com

© 2016 Eaton
All Rights Reserved
Printed in USA
Publication No. IM04302004E / Z18696
September 2016