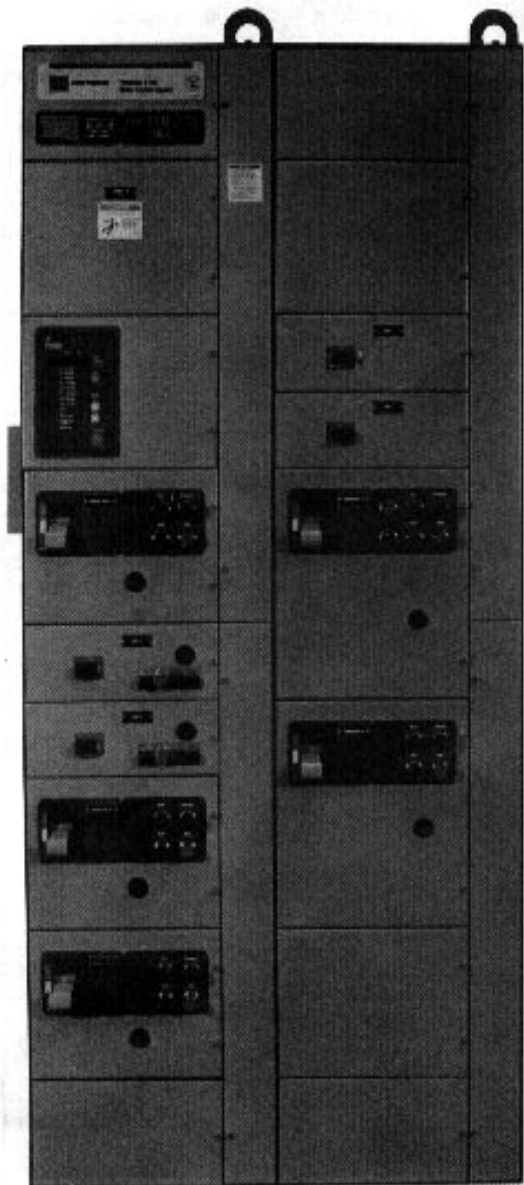

Freedom 2100
Motor Control Center

Installation and Maintenance Manual

TABLE OF CONTENTS

PART	DESCRIPTION	PAGE
1	General Information	2
2	Receiving, Handling & Storage	4
3	Installing Control Center Sections	5
4	Installing Conduit & Wiring	10
5	Incoming Line Connections	12
6	Overcurrent Protection Devices	14
7	Overload Relay Heater Selection	16
8	Inspection Prior to Energizing	18
9	Unit Installation & Adjustment	19
10	Maintenance	23
11	Plan Views	30
12	Related Instructions Leaflets	31

This electrical control equipment is designed to be installed, operated, and maintained by adequately trained workmen. These instructions do not cover all details, variations, or combinations of the equipment, its storage, delivery, installation, check-out, safe operation, or maintenance. Care must be exercised to comply with local, state, and national regulations, as well as safety practices, for this class of equipment. The maximum short circuit capability of the equipment should not be exceeded by connection to a source with higher capacity.

If maintenance or troubleshooting assistance is required, contact your nearest Westinghouse Engineering Service Division or Sales Office.

Part 1

GENERAL INFORMATION

THE MOTOR CONTROL CENTER

Although the Cutler Hammer Freedom 2100 Motor Control Center may be joined to existing Five Star, Series 2100, and Advantage installations using the same splice bar kits common to both. Units designed for the Freedom 2100 can be mounted in Five Star Series and Series 2100 sections, but the opposite is not recommended, because Five Star and Series 2100 units may lack terminal blocks and sufficient interrupting capacity. The Freedom 2100 MCC may be joined to existing Cutler-Hammer Freedom Unitrol and FI 0 Unitrol MCC's with a special splice bar kit, but units are not interchangeable.

CONTROL CENTER NOMENCLATURE

The numbers shown in parentheses in the following text refer to the balloon legends in Figure 2.

The Cutler Hammer Freedom 2100 Motor Control Center consists of one or more totally enclosed, dead front, free standing structural assemblies (1) 90 inches high which are compartmentalized to house individual control units. (2) With control units mounted in the front side only, the structure may be 16 or 21 inches deep. For mounting units back-to-back, the structure is 21 inches deep. Steel covers (7) enclose the structure at the top, sides and at the rear of front-mounted-only structures.

Each control center contains a main horizontal bus system (9) mounted at the top and extending across the length of the control center.

A vertical bus system (8) installed in each vertical section is connected to the horizontal bus to feed the individual control units. (6) The vertical bus is isolated by a full height barrier. (14) An optional labyrinth barrier provides both isolation and insulation. An automatic shutter is included with the labyrinth barrier system to cover the stab openings for each control unit.

At the top of each section, a door provides ready access to the top horizontal wireway (11) and ground bus (10). The horizontal wireway is isolated from the bus systems by steel barriers (12) which can be removed for installation and maintenance operations. Adequate space is provided for control wiring and top cable entry.

At the bottom of each section, a door (18) provides ready access to the bottom horizontal wireway, (19) and neutral bus (if provided). The bottom of each section is completely open to provide unrestricted bottom entry of cable and conduit. Channel sills may be installed across the bottom of the control center if specified, and an optional B. 8926-1

tional bottom plate may also be specified.

A vertical wireway 8 inches deep, (16) extending the full 90 inch height of the control center is located to the right of each unit compartment. This wireway is covered by two hinged doors (15) and contains cable supports to secure wire bundles and cables. The vertical wireway joins the horizontal wireway at top and bottom to provide unobstructed space for interwiring.

Each vertical section provides space to mount up to six controller units (2) with a minimum height of 12 inches, in increments of six inches, for a total of 72 inches of usable space. Controllers through NEMA Size 5 are drawout type (except reduced-voltage starters). These drawout unit assemblies are a completely self-contained package consisting of a steel enclosure, operating handle and electrical components. The drawout assembly slides into its compartment on guide rails (13) to provide easy withdrawal and reinsertion and to ensure precise alignment of the unit stabs with the vertical bus. Each drawout unit is held in place by a single quarter-turn latch (3) which can only be engaged when the unit stabs are fully mated with the vertical bus. Each unit has a separate door, (1) held closed by a minimum of two quarter-turn fasteners.

The operating handle on the controller unit (4) moves vertically. In the ON or TRIPPED positions, the handle interlocks with the unit door to prevent its opening. In this position, authorized personnel can open the door by turning the defeater mechanism screw. (21) With the unit door open and the operating handle in the ON position, another interlock to the divider pan prevents removal of the unit. This same interlock prevents insertion of the unit unless the handle mechanism is in the OFF position. To ensure that units are not energized accidentally or by unauthorized personnel, the handle mechanism can be padlocked in the OFF position.

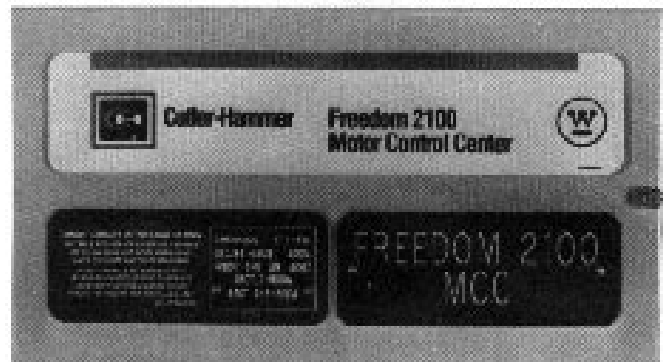

Fig. 1 Nameplate

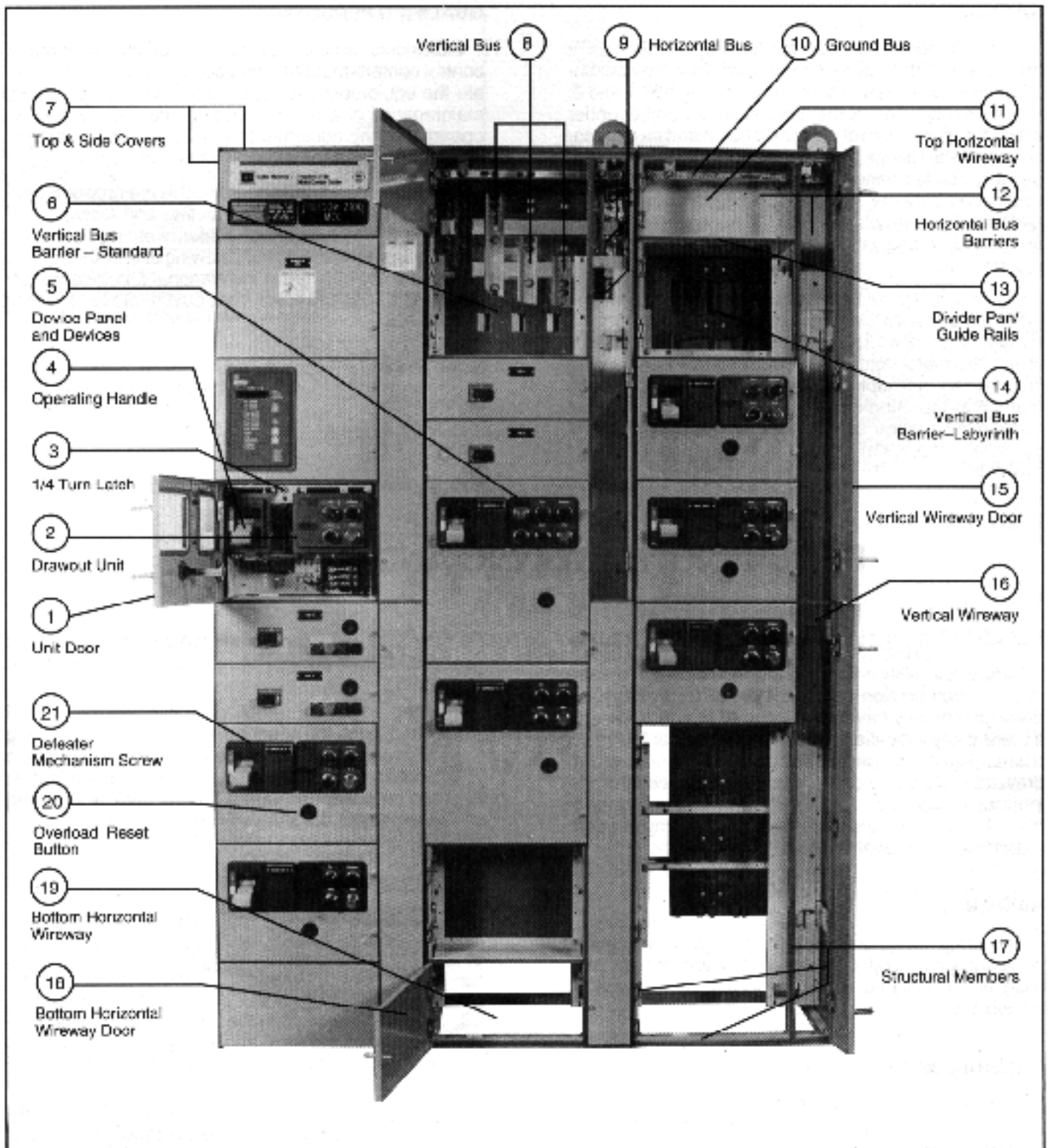

Fig. 2 Motor control Center Nomenclature

Space for a minimum of three padlocks is provided on each handle.

The device panel (6) is mounted on the drawout unit. It

will accommodate up to six pilot devices. The overload reset button (20) is mounted on the unit door.

RATINGS

Each Freedom 2100 Motor Control Center has a rating nameplate attached to the door of the top horizontal wireway of the primary section. See Figures 1 and 2. This nameplate shows the general order number under which the motor control center was built and its continuous electrical ratings, in terms of incoming line voltage, phases, and frequency, and ampere ratings of the horizontal bus and the vertical bus for each section. In addition, this nameplate shows the passive short-circuit (withstand) rating of the horizontal and vertical bus system.

The active short-circuit (interrupting) ratings of the main and unit short-circuit protective devices are shown on labels attached to the inside of each unit. Before installing a motor control center, calculate and record the fault current available at the incoming line terminals. Verify that the short-circuit withstand and short-circuit interrupting ratings of the units in the motor control center are

appropriate for the fault current available.

QUALIFIED PERSONNEL

Individuals who install, operate or maintain motor control centers must be trained and authorized to operate the equipment associated with the installation and maintenance of a motor control center, as well as the operation of the equipment that receives its power from controller units in the motor control center.

Such individuals must be trained in the proper procedures with respect to disconnecting and locking OFF power to the motor control center, wearing protective clothing and equipment, and following established safety procedures as outlined in the *National Electrical Safety Code (ANSI C2)* and *Electrical Equipment Maintenance (NFPA 70B)*.

Part 2 RECEIVING, HANDLING AND STORAGE

RECEIVING

Before and after unloading the motor control center, inspect each section and unit exterior for evidence of damage that may have been incurred during shipment. If there is any indication that the control center has been mishandled or shipped on its back or side, remove the drawout units and make a complete inspection of the internal structure, bus bars, insulators and unit components for possible hidden damage. Report any damage found to the carrier at once.

HANDLING

The following guidelines are provided to help avoid personal injury and equipment damage during handling, and to facilitate moving the motor control center at the job site.

GENERAL HINTS

1. Handle the motor control center with care, to avoid damage to components and to the enclosure or its paint finish.
2. Keep the motor control center in an upright position.
3. Insure that the moving means has the capacity to handle the weight of the motor control center.
4. The control center should remain secured to the shipping skid until the motor control center is in its final

- location.
5. Exercise care during any movement and placement operations to prevent falling or unintentional rolling or tipping.
6. Lifting angles for handling by overhead crane are bolted to the top of each shipping section. Handling by overhead crane is preferable but when crane facilities are not available, the motor control center can be positioned with a fork-lift truck or by using rollers under the shipping skid.

OVERHEAD CRANE

1. See Figure 3 for recommended lifting configuration.
2. Select or adjust the rigging lengths to compensate for any unequal weight distribution, and to maintain the motor control center in an upright position.
3. To reduce tension on the rigging and the compressive load on the lifting angles, do not allow the angle between the lifting cables and vertical to exceed 45 degrees.
4. Use slings with safety hooks or shackles. **Do not pass ropes or cables through lifting angle holes.**
5. After removing the lifting angles, replace the mounting hardware to prevent the entrance of dirt, etc.

FORK-LIFT TRUCK

Motor control centers are normally top and front heavy. Balance the load carefully and steady, as necessary, while moving. **Always use a safety strap when handling with a fork-lift.**

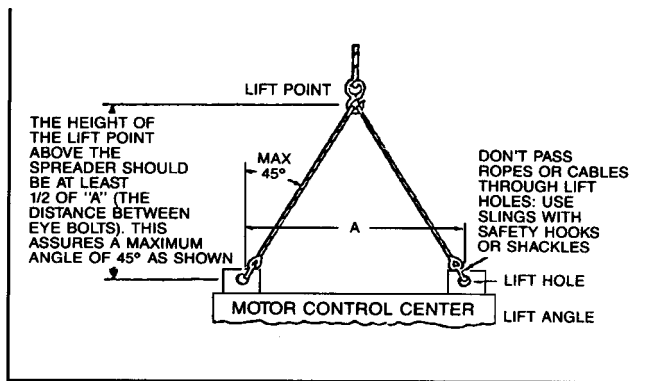

Fig. 3 Correct Use of Lifting Angle

ROLLERS

Rod or pipe rollers, with the aid of pinch bars, provide a simple method of moving the motor control center on one floor level, if there is no significant incline. Roll the motor control center slowly, and steady the load to pre-

vent tipping.

STORAGE

When a motor control center cannot be installed and placed into operation immediately upon receipt, take steps to prevent damage by condensation or harsh environmental conditions. If the motor control center cannot be installed in its final location, store it in a clean, dry, ventilated building, heated to prevent condensation, and protected from dirt, dust, water, and mechanical damage. When storage conditions are less than ideal, install temporary electrical heating, typically in the form of light bulbs, totaling 150 watts per section, hung in the vertical wireway, or by applying power to self-contained space heaters that the motor control center may be equipped with. Remove all loose packing and flammable materials before energizing any of the heating ele-

Part 3 INSTALLING CONTROL CENTER SECTIONS

ments.

GENERAL

Freedom Series 21 00 Motor Control Centers (MCC's) are designed for installation in accordance with both the *National Electrical Code (NEC)*, *NFPA 70*, and the *National Electrical Safety Code (NESC)*, *ANSI C2*.

Caution - If work is involved in connecting the control center with existing equipment, ensure that incoming power is disconnected before work is begun. Disconnecting means should be locked out and/or tagged out of service. Where it is not feasible to de-energize the system, the following precautions should be taken:

- A) Persons working near exposed parts that are or may be energized should be instructed and should use practices (including appropriate apparel, equipment, and tools) in accordance with the NESC.
- B) Persons working on exposed parts that are or may be energized should, in addition, be qualified persons who have been trained to work on energized circuits.

INSTALLATION

1. Before any installation work is begun, consult all drawings furnished by Cutler-Hammer as well as all applicable contract drawings for the installation. Give particular attention to the physical location of units in the control center and their relation to existing or planned conduit, busways, etc. Provide for future conduit entrance prior to control center installation.
2. Locate the control center in the area shown on the building floor plans. If in a wet location or outside of the building, protect the control center from water entering or accumulating within the enclosure. Recommended clearances or working spaces are as follows:
 - a) Clearance from walls (where not rear accessible) - a minimum of 1/2inch for indoor and 6 inches for outdoor or wet locations.
 - b) Clearance from front of MCC (working space) minimum of 3 feet for control centers without exposed live parts. See NEC 110-16d. NOTE: This working space should not be used for storage and should have adequate lighting.
3. Since control centers are assembled at the factory on smooth and level surfaces to assure correct alignment of all parts, control centers should be securely

mounted on a level surface. The foundation furnished by the purchaser must be true and level, or the bottom frames must be shimmed to support the entire base in a true plane. It is recommended that leveled channel sills under both the front and rear of the control center be used to provide this level base. Drill and tap the channel sills for mounting bolts in accordance with the applicable floor plan drawing and then either install the MCC level with, or on top of, the finished floor. If sills are grouted in concrete, the mounting bolts should be screwed in place and remain until the concrete has hardened.

4. For bottom entry, position the motor control center so that the conduit stubs or floor openings are located in the shaded areas shown on the MCC floor plan drawings (refer to pages 30 and 31 for floor plan dimensions). The shaded areas represent the open space available for conduit entry through the bottom of each section. A shaded area may be restricted if large controllers or autotransformers are mounted in the bottom of the sections. If optional bottom plates are supplied, the plates may be removed and drilled for conduit entry.
5. Install the MCC in its final position, progressively leveling each section and bolting the frames together if they are separated. If necessary, secure the MCC to walls or other supporting surfaces. Do not depend on wooden plugs driven into holes in masonry, concrete, plaster, or similar materials. See NEC 110-13.
6. If two or more shipping sections are to be joined into an integral assembly or a shipping section is to be joined to an existing section, refer to paragraphs below before proceeding with the installation.
7. Ground and bond the motor control center as follows:
 - a) Motor control centers used as service equipment for a grounded system or as an incoming line section for a separately-derived previously grounded system:
 - i) Run a grounding electrode conductor (ground wire) having a size in accordance with NEC 250-94 from the grounding electrode to the MCC ground bus or ground terminal provided. See also NEC 250-91 (a) and 92(b).
 - ii) If the system is grounded at any point ahead of the MCC, the grounded conductor must be run to the MCC in accordance with NEC 250-23(b), and connected to the ground bus terminal.
 - iii) Do not make any connections to ground on the load side of any neutral disconnecting line or any sensor used for ground-fault protection. Do not connect outgoing grounding conductors to the neutral.
 - b) Motor control centers used as service equipment for an ungrounded system or as an incoming line section for a separately-derived previously ungrounded system:

i) Run a grounding electrode conductor (ground wire) having a size in accordance with NEC 250-94 from the grounding electrode to the MCC ground bus terminal. See NEC 250-91 (a) and 92(b).

c) Motor control centers not used as service equipment nor as an incoming line section for a separately-derived system, and used on either a grounded or ungrounded system:

i) Ground the MCC ground bus by means of equipment grounding conductors having a size in accordance with NEC 250-95 or by bonding to the raceway enclosing the main supply conductors in accordance with NEC 250-91 (b).

8. When all wiring and adjustments are complete, close all unit and wireway doors.
9. In damp indoor locations, shield the MCC to prevent moisture and water from entering and accumulating.
10. Unless the motor control center has been designed for unusual service conditions, it should not be located where it will be exposed to ambient temperatures above 40°C (104°F), corrosive or explosive fumes, dust, vapors, dripping or standing water, abnormal vibration, shock or tilting.

JOINING COMPATIBLE SECTIONS

If two more shipping blocks are to be joined into an integral assembly, or a section added to an existing installation, splicing or horizontal bus, ground bus, neutral bus and joining of the adjacent vertical sections must be planned with the installation.

1. Remove the side sheets from adjacent vertical sections to be joined. (These sheets will have been removed from factory-assembled sections.)
2. The horizontal bus splice plates and connection hardware will be shipped with the MCC attached to one end of shipping section. Refer to Figure 4. This method provides the most convenient access to the bolts, and eliminates the need to remove the horizontal bus barriers in that structure. Should the existing bus be oxidized, sand lightly with a fine aluminum oxide paper. CAUTION - Do not use emery cloth or any abrasive containing metal.

3. Remove the upper horizontal wireway door from the structure on the right side of the left-hand (LH) section and remove the two-piece wireway barrier to provide access to the ends of the bus in that section.
4. Move the section in place, aligning the upright structural channels and bottom channels. Alignment of the section with floor sills and foundation provisions will be facilitated by removing the bottom horizontal wireway doors. Using the "U" type frame clamps provided, clamp adjacent front upright channels together at the top, bottom and approximate center of the vertical structure. This operation will be facilitated by removing the vertical wireway doors from the left-hand structure and one or more drawout units from the right-hand structure. See Part 9.
5. If rear access is available, "U" clamps should also be used to clamp the rear upright channels together. In front-mounted-only structures this will require removal of the adjacent back sheets. In a back-to-back mounted structure, remove the vertical wireway doors and one or more drawout units as above.
6. Secure the sections to the floor sills or mounting bolts as provided for the installation.
7. Bolt the horizontal bus splice plates to the bus in the left-hand structure, torquing all bus splice bolts to 275 pound-inches (23 pound-feet). See Figure 5.
8. Replace all unit, bus barriers, and doors.

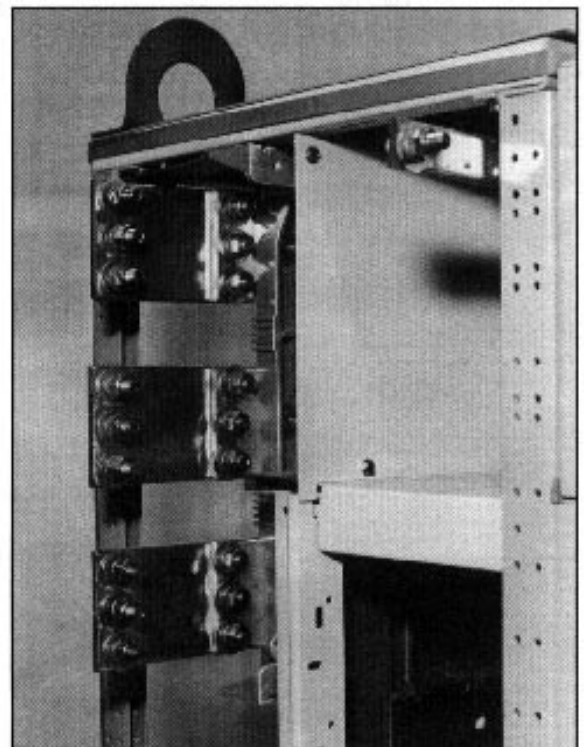

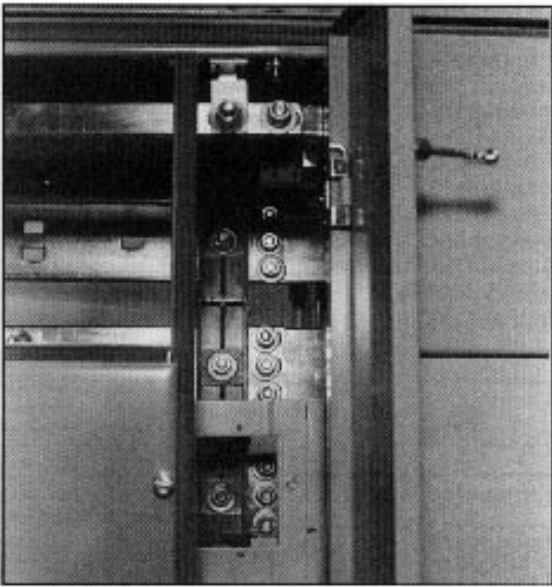

Fig. 5 Access to LH Splice Plate connections

JOINING INCOMPATIBLE SECTIONS

Joining a Freedom 21 00 Motor Control Center to the equipment such as Type W and 11 -300 Control Centers will usually involve a transition section, installed between the two varieties of equipment. This transition section will be detailed on drawings provided by Cutler Hammer and the applicable contact drawings. If provided separately, it should be installed first. Review the overall installation task to determine whether the transition section should be attached to the existing equipment or to the Freedom 21 00 section, before it is move into place, and select the sequence which will provide best access to bus splicing and joining of the structures.

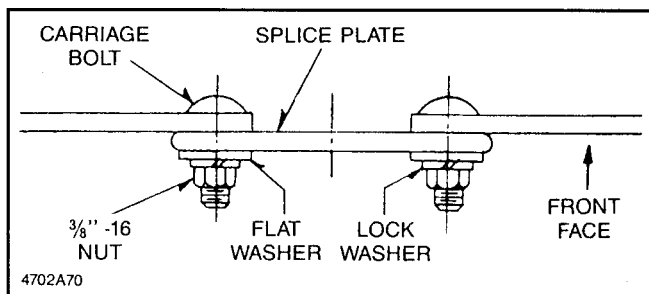

Fig. 6 Single Bar Splice Kit

SPLICE PLATES

Each splice plate kit consists of short pieces of bus bar the same width as the main horizontal bus of the MCC the kit is shipped with, four bolts per phase, an appropriate

quantities of related hardware. For a single bus bar per phase the hardware is used as shown in Figure 6 for either 16" or 20" deep enclosures. Each splice plate is punched with rectangular holes to accept a square shank carriage bolt that will not rotate as the nut is tightened.

Where the MCC is built with two horizontal bus bars per phase, the splice plates are installed as shown in Figure 7. The top edge of Figures 7 through 10 represents the back side of the MCC. The top portion of each of these figures applies to 20" deep enclosures and the lower portion to 16" deep enclosures. Note that for all but the single-bar per phase (Figure 6) installation, the 16" deep enclosures require the use of a nut plate that is mounted with the same carriage bolt used to attach the horizontal bus bars to the channel-shaped insulators. Install these nut plates before mounting the splice plates. Tighten the splice plate bolts with a driving torque of 275 pound-inches (23 pound-feet).

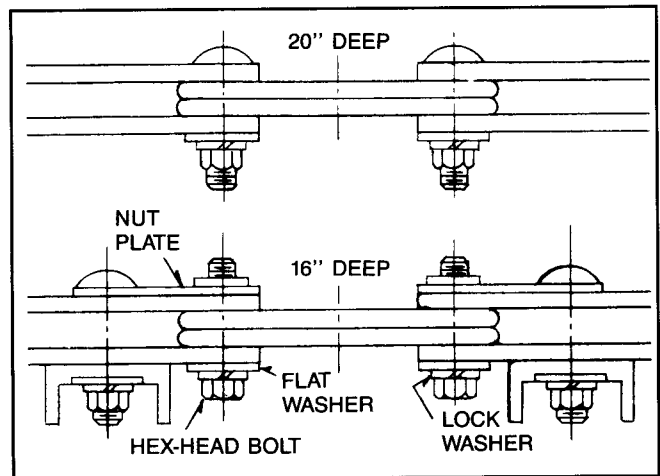

Fig. 7 Double Bar Splice Kit

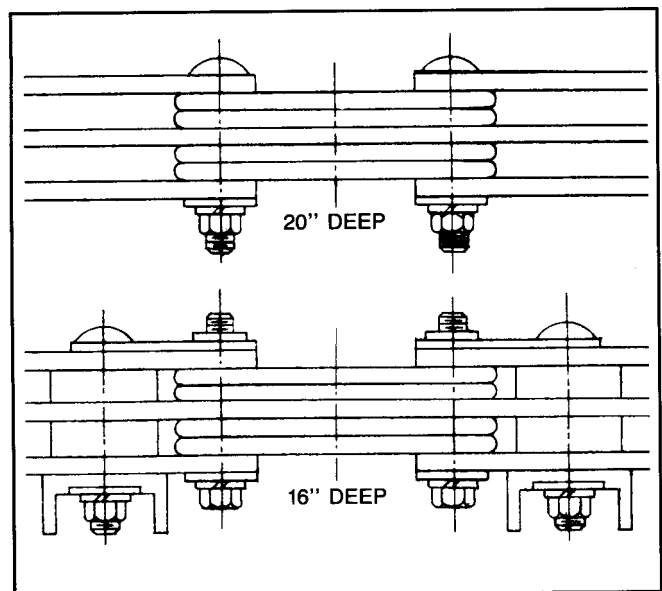

Fig. 8 Triple Bar Splice Kit

TYPE 3R ENCLOSURES

Where the MCC is supplied in a Type 3R enclosure for an outdoor application, apply roof splice caps at each shipping block junction to maintain the enclosure integrity.

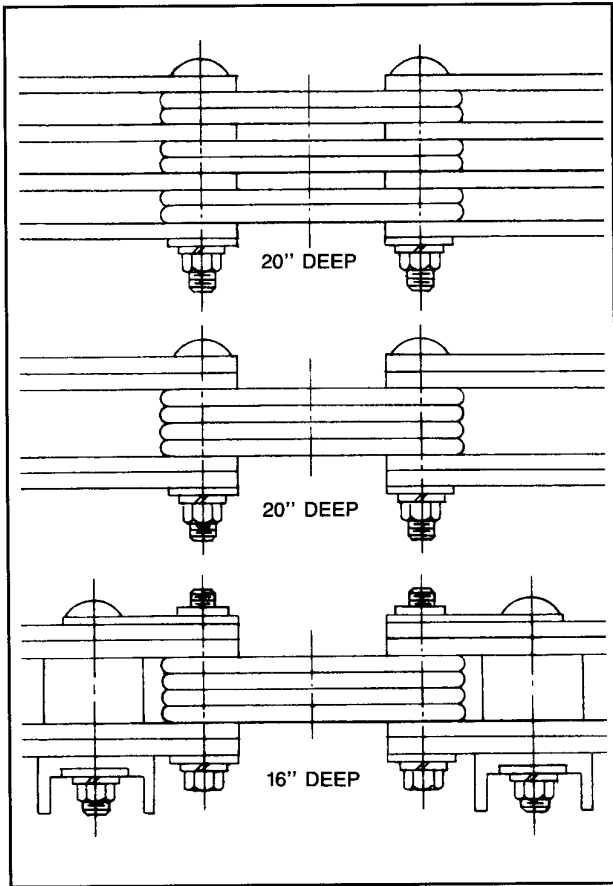

Fig. 9 Quadruple Bar Splice Kits

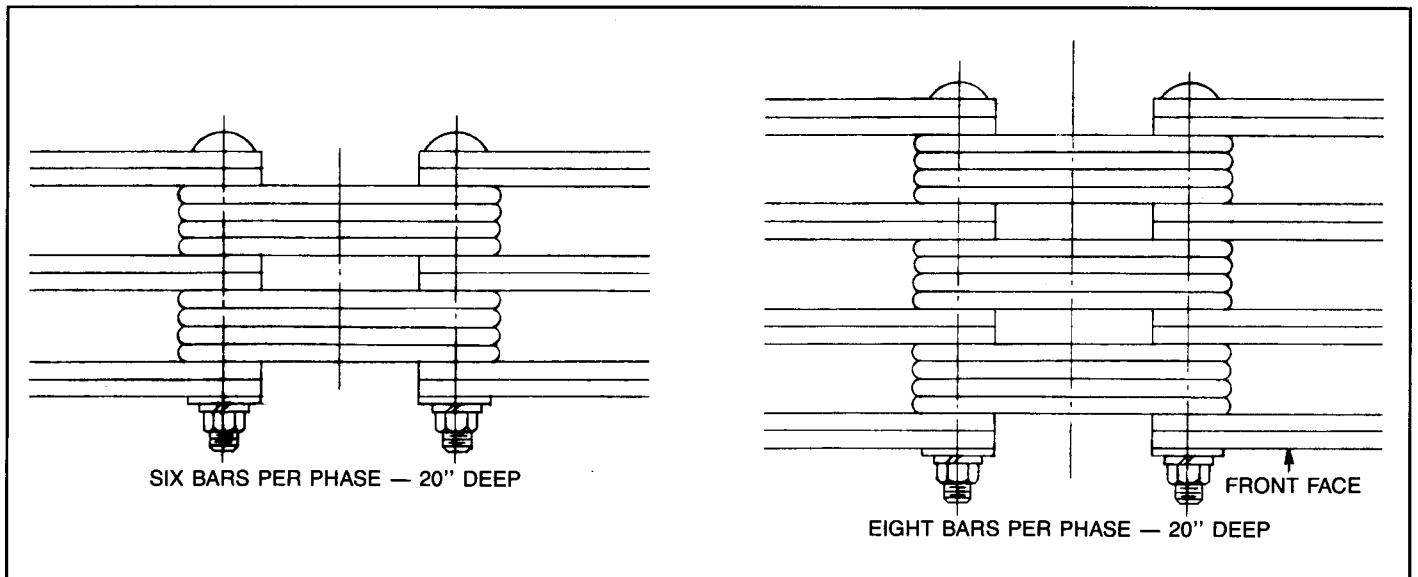

Fig. 10 Six and Eight Bar Splice Kits

JOINING FREEDOM 2100 TO FREEDOM UNITROL OF F10 UNITROL

Consult the assembly instructions supplied with every Freedom 2100 Motor Control Center set up for splice to Freedom Unitrol of F10 Unitrol.

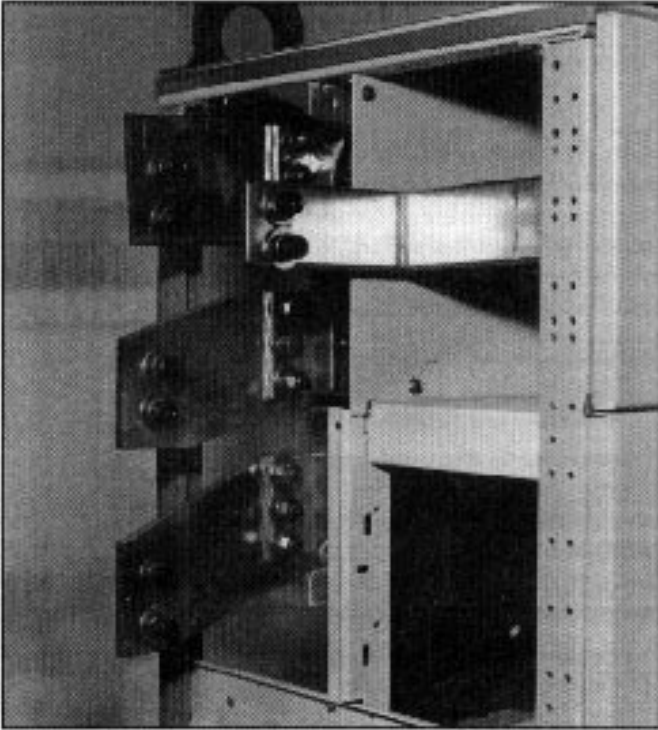

Fig. 11 Splice Plates Attached to Freedom 2100 - Horizontal bus and Ground Bus at Top.

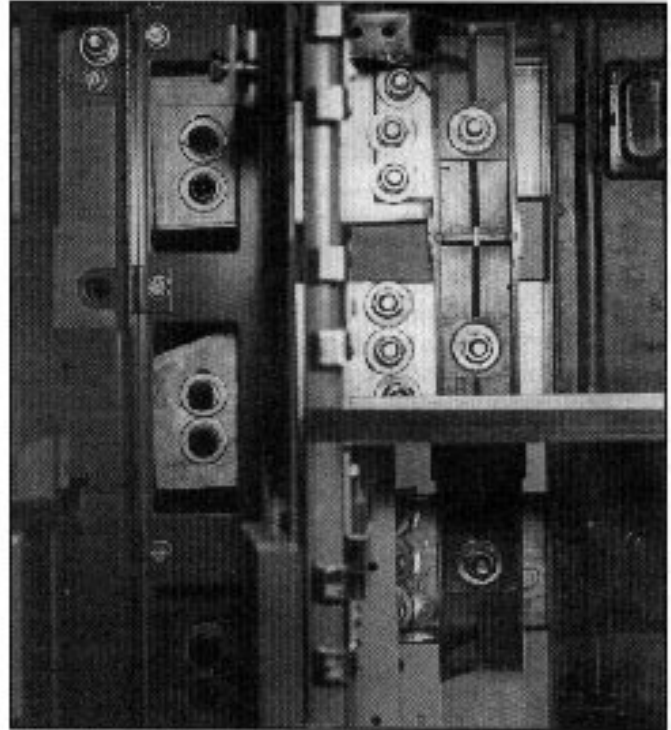

Fig. 12 Horizontal bus Splice Freedom unitrol On Left, Freedom 2100 on Right.

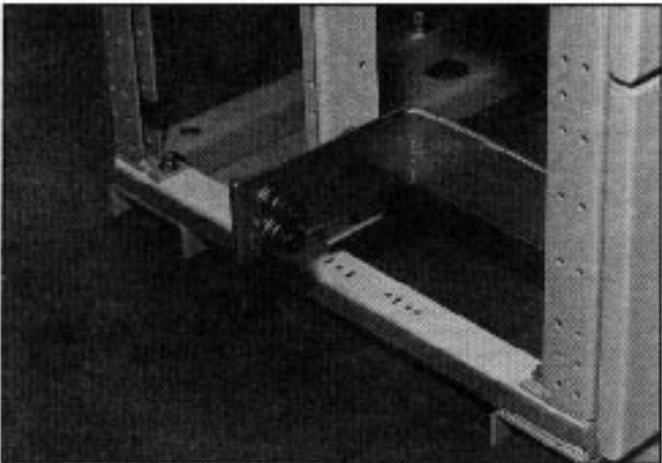

Fig. 13 Splice Plate Attached to Freedom 2100 - Ground Bus at Bottom.

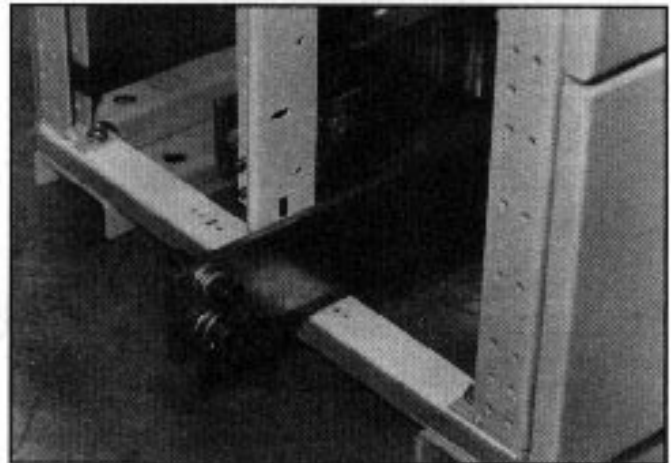

Fig. 14 Splice Plate Attached to Freedom 2100 - Neutral Bus.

PART 4

INSTALLING CONDUIT AND WIRING

CONDUIT

Install conduit in such a manner as to prevent water from entering and accumulating in the conduit or the enclosure. Eliminate sags in conduit. Have the conduit enter the motor control center (MCC) in the areas designated for conduit entry on the plan views. See pages 30 and 31 of this booklet and outline drawings shipped with the MCC. Keeping conduit within the shaded areas shown in the plan views will avoid cable interference with structural members and live bus. (See Part 12.)

WIRING

Install the line and load conductors sized in accordance with the NEC. **Use copper wire only for control terminations. Use copper wire only for power terminations unless they are marked "CUIAL."** Use conductors with a temperature rating of 75°C or higher, but regardless of the insulation temperature rating select the wire size on the basis of 75°C wire ampacity. Using a higher temperature wire ampacity table often results in a smaller cross-section of copper available for carrying heat away from terminals.

Install insulated wire and cable at a temperature sufficiently warm to prevent the insulation from cracking or splitting.

When more than one conduit is run from a common source or to a common load, be sure to have each conduit carry conductors from each phase and the same number of conductors per phase. If the phase conductors are not distributed uniformly, eddy currents will be generated in the steel between the conduits.

Locate conductors within the MCC to avoid physical damage and to avoid overheating. Secure incoming power lines in a manner adequate to withstand the forces which will act to separate the conductors under short-circuit conditions. Use the cable ties furnished in both horizontal and vertical wireways to support the load and interconnection wire. Use a shielded communications cable inside of flexible metal conduit to protect very low voltage signals transmitted to or from a computer or programmable controller.

Lugs furnished with the MCC and its components are for Class B and Class C stranding. Verify the compatibility of wire size, type, and stranding with the lugs furnished. Where they are not compatible, change the wire or lugs accordingly. If crimp lugs are used, crimp with the tools recommended by the manufacturer.

Use care in stripping insulation to avoid nicking or ringing the metal.

All field wiring to control units should be made in accordance with the wiring drawings that are furnished with the control center. Load and control wiring can be brought in through the upper and/or lower horizontal wireways. Determine the type of wiring installed in the control center (NEMA Type B or C) and proceed per the appropriate paragraph below.

The phase sequence of the power circuit load terminals (left-to-right: T1, T2, T3) in units mounted on the rear side of the MCC is opposite to that of the load terminals in units mounted on the front side of a back-to-back MCC. To obtain the same direction of rotation for a motor connected to a rear-mounted unit as for one connected to a front-mounted unit, relabel the terminals in the rear-mounted unit: T3, T2, T1, and wire accordingly. Refer to the warning sticker supplied with rear-side units.

When making connections to the load terminals be sure to leave sufficient slack in the wires so that the unit can be withdrawn to the detent position for maintenance. See page 20.

NEMA TYPE B WIRING

Each control unit is factory assembled with devices interwired within the unit. In addition, all control wiring is carried to unit terminal blocks mounted on the right-hand side of the unit. See Figure 15. Bring the field wiring of control wires from a horizontal wireway into the vertical wireway on the right-hand side of the applicable control unit and terminate them at the unit terminal blocks. Bring load wiring from the vertical wireway, under the bottom right-hand side of the unit, to terminations within the unit. See below.

ENGAGING PULL-APART TERMINAL BLOCKS

The male portion of the pull-apart terminal block is located in a plastic bag tied to the pivot rod inside the unit. This terminal block can be wired outside of the vertical wireway. To engage the terminal block, align the fingers of the male connector with the slot at the back of the female portion of the terminal block. Then rotate the male portion forward and to the left into the female portion of the terminal block.

Each male portion of the pull-apart terminal block has two cavities adjacent to the center terminal screw to

accept the blade of an electrician's screwdriver used to cam the block into and out of engagement. Each male

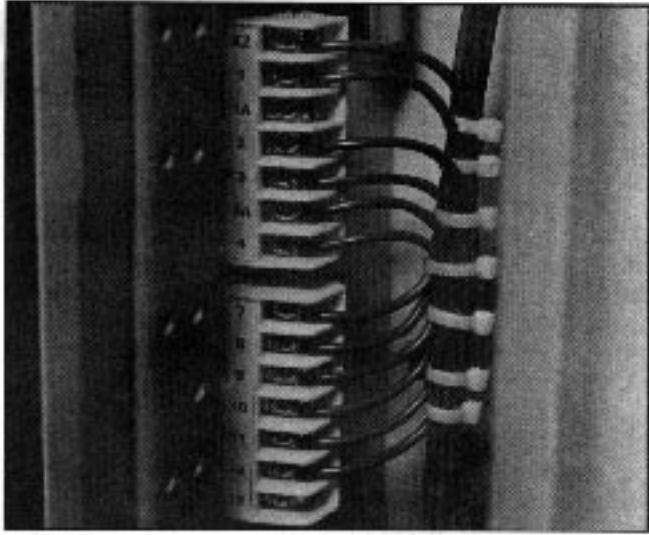

Fig. 15 Unit Terminal Blocks

portion also has a rear slot that can engage the edge of the unit frame where it can be mounted for ease in trouble-shooting.

NEMA TYPE C WIRING

Each control unit is factory assembled with device interwired within the unit. In addition, all control wiring is carried to unit terminal blocks on the side of the unit and from these unit blocks, along with load wiring through Size 3, to master terminal blocks located at the top or bottom of the structure. See Figure 16. Master terminal blocks can be either fixed or drawout mounted. In the drawout design the terminal blocks are rack mounted to permit withdrawal of the entire assembly for ease of wiring during installation and maintenance. Bring field wiring from the horizontal wireway to the master terminal blocks except for load wiring larger than Size 3. These latter load wires should be carried into the vertical wireway and under the bottom right-hand side of the unit to terminations within the unit.

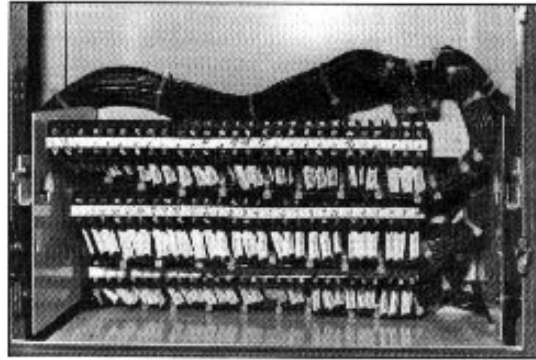

Fig. 16 Master Terminal Blocks

PART 5 INCOMING LINE CONNECTIONS

OVERCURRENT PROTECTION

All ungrounded conductors in a motor control center (MCC) installation require some form of overcurrent protection in order to comply with Section 240-20 of the NEC. Such overcurrent protection for the incoming lines to the MCC is in the form of fuses or a circuit breaker located at the transformer secondary that supplies the MCC. The conductors from the transformer secondary constitute the feeder to the MCC, and the "10-foot rule" and the "25-foot rule" of NEC 240-21 apply. These latter exceptions to the general rule allow the disconnect means and overcurrent protection to be located in the MCC, provided the feeder taps from the transformer are sufficiently short and other requirements are met.

MAIN DISCONNECTS

A circuit breaker or a circuit interrupter combined with fuses controlling the power to the entire MCC may provide the overcurrent protection required as described above or may be a supplementary disconnect (isolation) means. See Figures 17, 18 and 19.

When the MCC has a main disconnect, bring the incoming lines (the feeders) to the line terminals of the circuit breaker or circuit interrupter. The load side of the

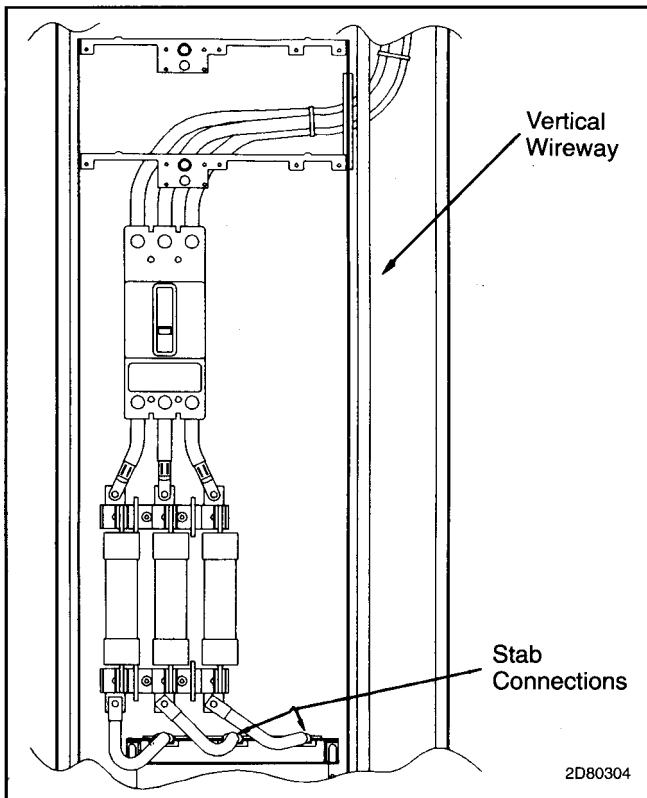

Fig. 17 Main Disconnect with Stab Load Connections

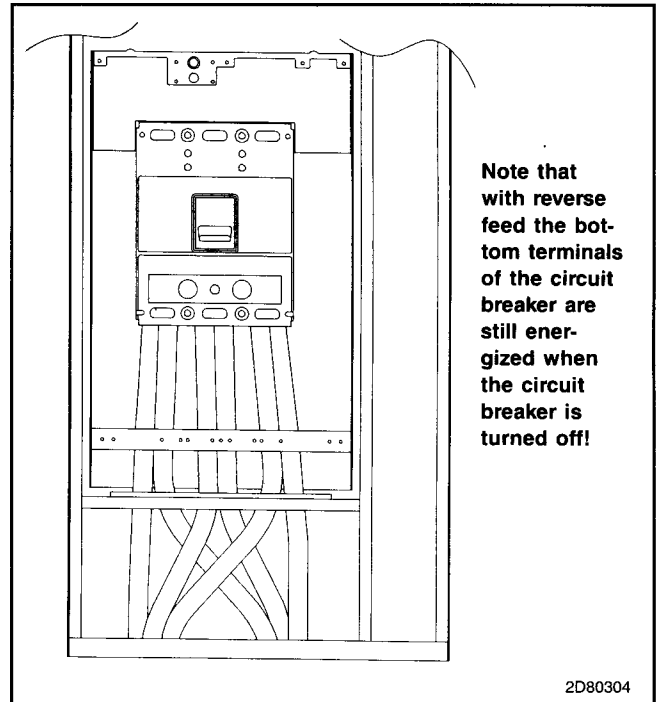

Fig. 18 Main Circuit Breaker with Reverse Feed

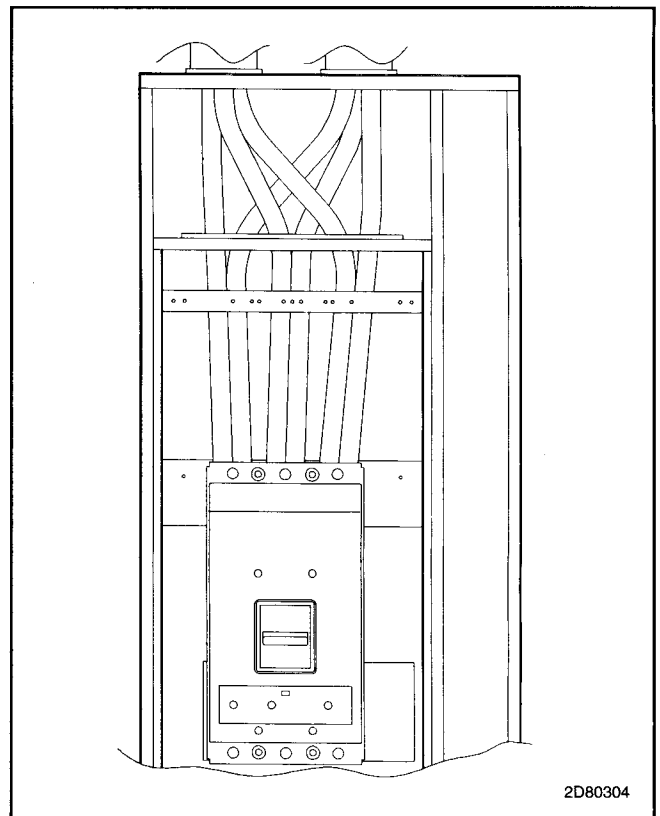

Fig. 19 Main Circuit Breaker

circuit breaker or the load side of the fuses associated with the circuit interrupter has already been connected to the MCC bus bar distribution system. In the case of main disconnects rated 400 amperes or less, this load connection is made by stab connections to vertical bus bars which connect to the horizontal bus distribution system. See Figure 17.

INCOMING LINE LUGS

Where the overcurrent protection for the MCC is at a remote location, the MCC feeder lines are connected to incoming line lugs attached to the bus bar distribution system. See Figure 20. For high-ampere rated horizontal bus bar systems, the incoming line lugs are mounted on vertical risers which connect to the horizontal bus bars. See Figure 21.

SHORT-CIRCUIT BRACING

All incoming lines to either incoming line lugs or to main disconnects must be braced to withstand the mechanical forces created by a high fault current. With the remainder of a Freedom 21 00 MCC braced for not less than 65,000 amperes (rms symmetrical), the installing electrician needs to anchor the cables at the incoming line connections sufficiently and tighten the lugs correctly. Each incoming line compartment is equipped with a two-piece spreader bar located about nine inches from the conduit entry. Use this spreader bar and appropriate lacing material to tie cables together where they can be bundled and to hold them apart where they are separated. In other words, position the incoming line cables and then anchor them in place. See Figure 22 and the instruction sheet inside of the MCC.

MAKING CONNECTION

CAUTION: All incoming line compartments present an obvious hazard when the door is opened or cov-

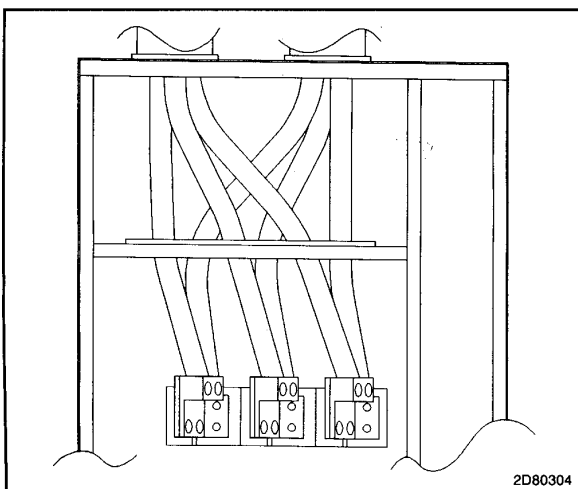

Fig. 20 Incoming Line Lug Connections

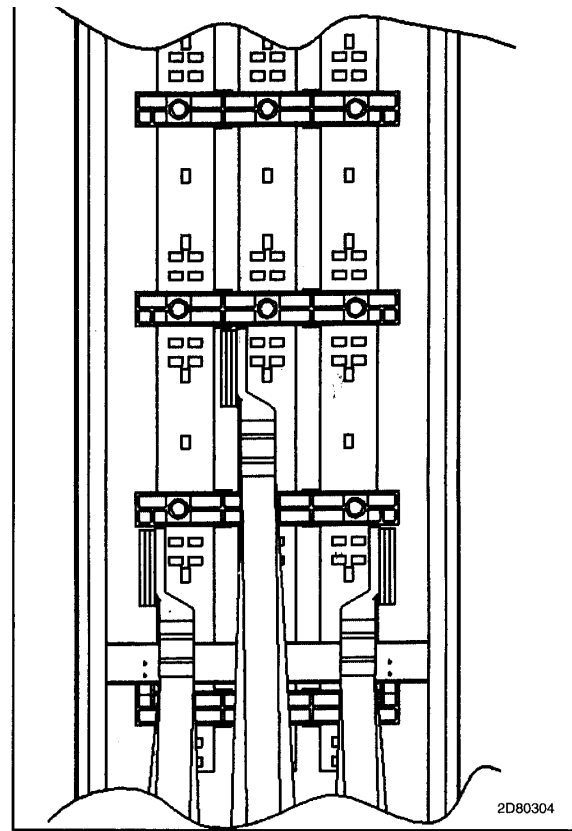

Fig. 21 Incoming Line Compartment, 2000A

ers are removed with power on. When working in this area, the incoming feeder should be de-energized.

Before beginning work on incoming line connections, refer to all drawings furnished by Cutler Hammer, as well as, all applicable contract drawings for the particular installation.

Depending on the location, size and type of the incoming arrangement, remove one or more horizontal and vertical wireway doors, and selected units to provide complete access. See Part9 for unit removal instructions.

For top entry, the top cover plates are easily removed for drilling or punching operations.

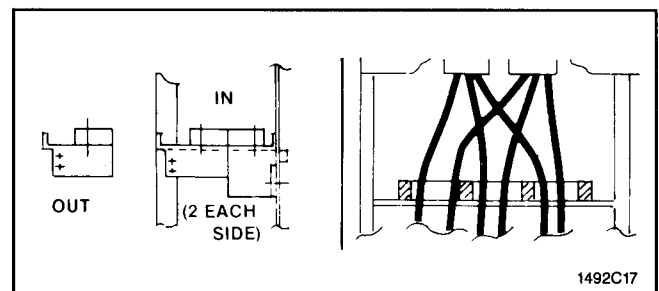

Fig. 22 Spreader Bar For Top Entry

PART 6 OVERCURRENT PROTECTION DEVICES

DEVICE SELECTION

Articles 240 and 430 of the NEC contain the rules for selecting fuses, circuit breakers and overload relays by type and by voltage and ampere rating. Follow these rules for feeder circuits, and the instructions attached to the inside of the left-most vertical wireway door, for motor branch circuits. Select and install overload relay current elements (heaters) based on the motor service factor and full-load current. Ambient compensated overload relays are used in motor control centers (MCC's) to offset the temperature gradient which occurs from top to bottom in a loaded vertical section.

HEATERS MUST BE INSTALLED IN THE STARTER OVERLOAD RELAY ASSEMBLIES BEFORE THE STARTER IS ENERGIZED.

C306 THERMAL OVERLOAD RELAYS (Fig. 24)

C306 Overload Relays are provided on Freedom Starters. Four sizes are available for overload protection up to 114 amperes. Features include:

- Selectable Manual or Automatic Reset operation.
- Interchangeable Heater Packs adjustable $\pm 24\%$ to match motor FLA and calibrated for use with 1.0 and 1.15 service factor motors.
Heater packs for 32 ampere overload relay will mount in 75 ampere overload relay-useful in derating applications such as jogging.
- Class 10 or 20 heater packs. (Fig. 24) Use Class 10 heaters with fusible or thermal magnetic breaker disconnects only.
- Bimetallic, ambient compensated operated. Trip free mechanism.
- Electrically isolated NO-NC contacts (pull RESET button to test).
- Overload trip indication.
- Single phase protection.
- UL listed, CSA certified and NEMA compliance.

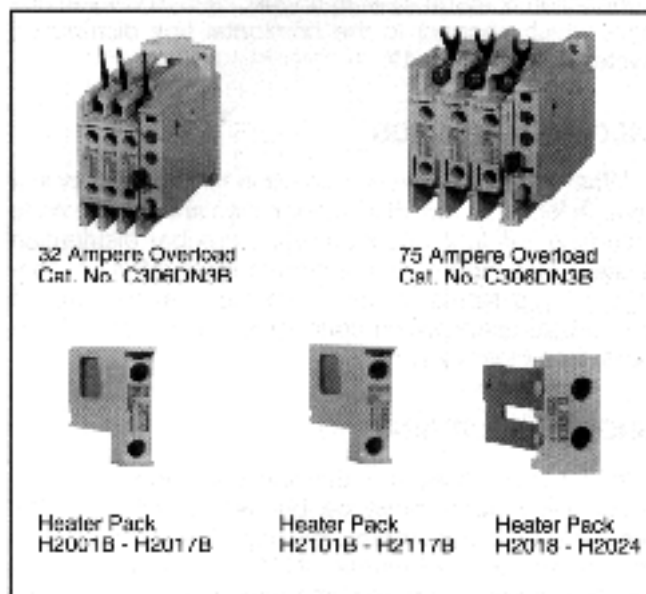

Fig.24 C306 Thermal Overload Relay and Heater Pack.

C306 OVERLOAD RELAY SETTING

FLA DIAL ADJUSTMENT- For motors having a 1.15 service factor, rotate the FLA adjustment dial to correspond to the motor's FLA rating. Estimate the dial position when the motor FLA falls between two letter values as shown in Fig. 23.

For motors having a 1.0 service factor, rotate the FLA dial one-half position counterclockwise (CCW).

MANUAL/ AUTOMATIC RESET -The overload relay is factory set "M" for manual reset operation as shown in Fig. 23. For automatic reset operation, turn the reset adjustment dial to the "A" position.

Automatic reset is not intended to two-wire devices.

TEST FOR TRIP INDICATION -To test overload relay for trip indication when in manual reset, pull out the blue reset button. An orange flag will appear indicating that the device has tripped. Push reset button in to reset.

TEST FOR TRIP INDICATION - To test overload relay for trip indication when in manual reset, pull out the blue reset button. An orange flag will appear indicating that the device has tripped. Push reset button in to reset.

WARNING -To provide continued protection against fire or shock hazard, the complete overload relay must be replaced if burnout of the heater element occurs.

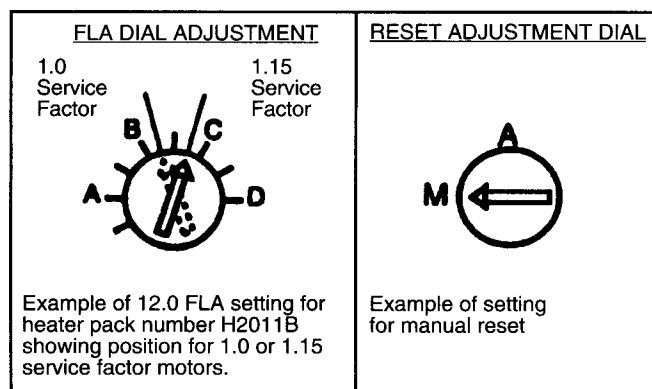

Fig. 23 Overload Relay Settings

CURRENT TRANSFORMERS

When current transformers are used with overload relays, the current through the overload relay heater is related to the motor full-load by the inverse of the current transformer ratio.

WARNING: Do not ever remove heaters from Size 5 and larger starters to check unit operation. These starters use current transformers to drop the current to the range of the size 1 overload relay. Operation with heaters removed will not interrupt voltage to the motor and will generate dangerous voltages in the open secondary of the current transformer.

MOTOR CIRCUIT PROTECTOR (HMCP)

AFTER INSTALLATION OF THE CONTROL CENTER, EACH MCP MUST BE ADJUSTED TO ACTUAL MOTOR FULL-LOAD AMPERES (FLA) SO THAT IT WILL TRIP AT ANY CURRENT WHICH EXCEEDS STARTING INRUSH. This setting provides low-level fault protection. The first half-cycle inrush will vary with the motor characteristics. Motors with locked-rotor currents of six times motor full-load amperes will usually require an instantaneous magnetic setting of 7 to 11

times motor full-load amperes to prevent tripping when starting.

A cam to accept a small narrow-blade electrician's screwdriver is near the lower left corner and around which are eight lettered adjustment points, calibrated in trip amperes. See Figure 25. Adjustment should never exceed 13 times FLA which is in accordance with NEC requirements for magnetic-trip-only breakers. **Adjustment should be made as follows:**

1. Obtain FLA from motor nameplate.
2. Multiply FLA by 13.
3. Set the cam to the highest trip setting which does not exceed the calculated figure of Item 2. This is the maximum setting that should be used.
4. Depress and turn the screwdriver adjustment counter-clockwise one setting at a time, until the breaker trips in starting and then adjust upward one setting position. This will insure that the circuit will open instantly on any current above the motor inrush, usually 7 to 11 time FLA.

The PUSH-TO-TRIP button checks the tripping function and is used to periodically exercise the operating mechanism. The button is designed to be operated by using a small screwdriver.

Freedom 21 00 MCC's are supplied with Type HMCP motor circuit protectors having an interrupting rating to match the short-circuit withstand rating of the bus bar system. For HMCP's in 225,400 and 600 ampere frame sizes, the magnetic-trip adjustment is set for each pole. A three-pole HMCP has three trip settings to adjust. Place all three poles at the same setting.

CURRENT LIMITERS FOR USE WITH TYPE HMCP AND FD BREAKERS

The addition of the current limiter provides interrupting capacity above the range handled by the HMCP in motor starters or by FD thermal-magnetic feeder breakers.

Each HMCP or FD breaker rated up to 150 amps has its own current limiter to provide coordinated protection against faults up to 1 00,000 amperes, rms symmetrical.

Built-in trip indicators in each phase immediately show when a fault has blown the current limiter and tripped the circuit breaker. This provides protection against single phasing. **After interrupting a fault, the current limiter will require replacement. After the fault has been cleared, the current limiter is replaced by the removal of three screws. The breaker can then be reset to provide for subsequent high overcurrent protection.**

TYPE HMCP AND FD CIRCUIT BREAKERS WITH TERMINAL END COVERS

Circuit breakers installed in units connected to 600 volt distribution systems require a terminal end cap to be installed on the line side. Replace the terminal end cap when replacing circuit breakers in such units.

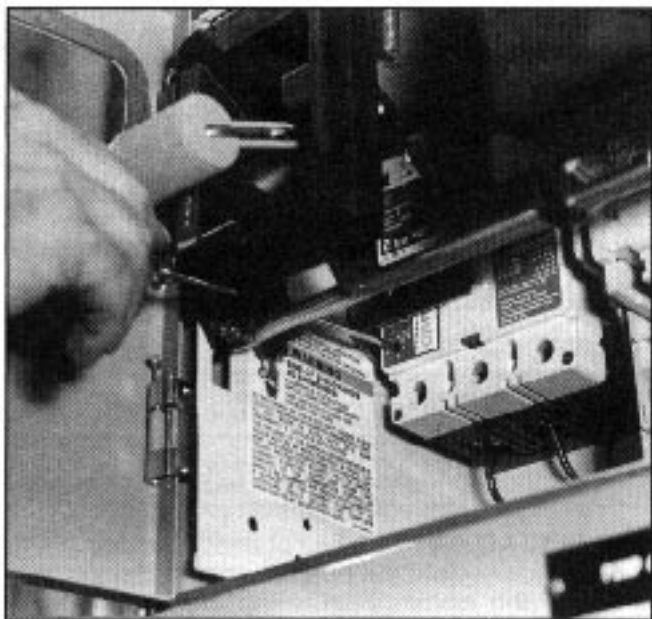

Fig. 25 HMCP Magnetic Adjustment

PART 7 OVERLOAD RELAY HEATER SELECTION

HEATER SELECTION AND INSTALLATION

Heaters should be selected on the basis of the actual full load current and service factor as shown on the motor nameplate or in the motor manufacturer's published literature.

When motor and overload relay are in the same ambient and the service factor of the motor is 1.15 to 1.25, select heaters and set **FLA** adjustment dial from the heater application table. **If the service factor of the motor is 1.0, or there is no service factor shown, rotate the FLA adjustment dial counter-clockwise one half (1/2) position.**

The conductors attached to the terminals of an overload relay act as a heat sink and are a consideration in establishing the current rating of each heater element. To prevent nuisance tripping, which will occur if undersized conductors are used, select the wire size as if the conductors had an insulation temperature rating of 75°C, even if the conductors actually used have a temperature rating higher than 75°C.

Protect heater and starter against short circuits by providing branch circuit protection in accordance with the National Electric Code.

Note: Before installing heater packs, refer to the motor nameplate for **FLA** (full load amps) and service factor (1.5 or 1.0). Select the heater pack from the proper table below.

To install:

A. Insert three (3) identically numbered heater packs into the overload relay with an **FLA** rating that includes the motor nameplate **FLA** (full load amps).

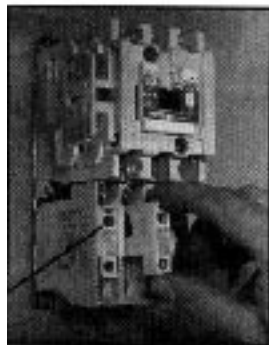

B. Tighten the heater pack mounting screws securely per recommended torque values listed below.

Heater Pack Numbers	Recommended Torque
H2001B thru H2017B H2018 thru H2024	9 lb-in [1 N · m] 24-30 lb-in [2.7-3.4 N·m]

C. Adjust the **FLA** adjustment dial to the motor nameplate **FLA** (full load amps).

THE OVERLOAD IS NOW SET FOR 1.15 SERVICE FACTOR.

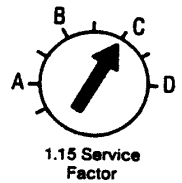

D. If the motor nameplate is 1.0 service factor, rotate the **FLA** adjustment dial counter-clockwise one half (1/2) position.

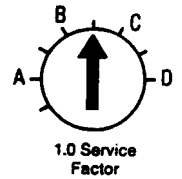

E. The overload is factory set for **M (MANUAL)** reset operation. If automatic reset is required, turn the reset adjustment dial to **A (AUTO)**. Automatic reset is not intended for two-wire control devices.

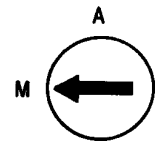

TO REMOVE HEATER PACKS

Loosen two (2) heater packs mounting screws and remove heater pack from overload relay.

OVERLOAD RELAY SETTING - This bimetallic ambient compensated overload relay is adjustable within the FLA range of the heater pack. Each heater pack is marked with its FLA ratings. With proper heater section, the overload relay will ultimately trip at 125% FLA for a 1.15 service factor motor and at 115% FLA for a 1.0 service factor motor.

HEATER SELECTION / INSTALLATION - Select the appropriate heater pack number which corresponds to the motor FLA rating for your application. Insert each heater into the overload relay and tighten heater mounting screws securely per table below.

NOTE: A total of three individual heaters **must** be installed in order for the overload relay to work properly.

Heater Pack Numbers	Torque
H2001B thru H2017B H2018 thru H2024	9 lb-in 24-30 lb-in

FLA DIAL ADJUSTMENT - For motors having a 1.15 service factor, rotate the FLA adjustment dial to correspond to the motor's FLA rating. Estimate the dial position when the motor FLA falls between two letter values as shown in the example.

For motors having 1.0 service factor, rotate the FLA dial one-half position counter-clockwise (CCW).

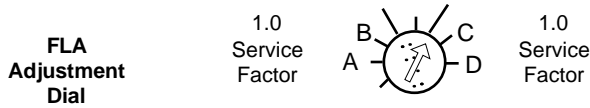

Example of a 12.0 FLA setting for a heater pack number H2011B showing position for 1.0 or 1.15 service factor motor.

MANUAL/AUTOMATIC RESET - The overload relay is factory set at "M" for manual reset operation as shown in the illustration. For automatic reset operation, turn the reset adjustment dial to the "A" position. Automatic reset is not intended for two-wire control devices.

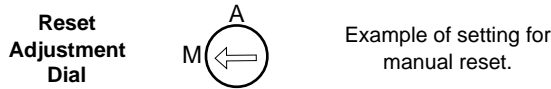

TEST FOR TRIP INDICATION - To test overload relay for trip indication when in manual reset, pull out the blue reset button. An orange flag will appear indicating that the device has tripped. Push reset button into reset.

NEMA SIZE 0 AND 1				SIZE F
HEATER PACK SELECTION TABLE				STD TRIP CLASS 20
MOTOR FLA RATING ◆				
FLA DIAL POSITIONS				
A	B	C	D	
.254	.306	.359	.411	H2001B
.375	.452	.530	.607	H2002B
.560	.676	.791	.907	H2003B
.814	.983	1.15	1.32	H2004B
1.20	1.45	1.71	1.96	H2005B
1.79	2.16	2.53	2.90	H2006B
2.15	2.60	3.04	3.49	H2007B
3.23	3.90	4.56	5.23	H2008B
4.55	5.50	6.45	7.40	H2009B
6.75	8.17	9.58	11.0	H2010B
9.14	10.8	12.4	14.0	H2011B
14.0	16.9	19.9	22.8	H2012B
18.7	22.7	26.7	30.7	H2013B ■
23.5	28.5	33.5	—	H2014B ■

MAXIMUM RATINGS

NEMA SIZE	AMPERES	SIZE	AMPERES
0	18		
1	27	F	32

Use 75°C copper conductors only
Max. Wire Size - 8 AWG

NOTE: After the above referenced settings have been made, rotate the FLA dial **one position clockwise** for these heaters (see table). If less than one position is available, rotate dial maximum. This note **does not** apply when these heaters are used with adapter base. Catalog No. C306TB1.

Exception does not apply to AN16DN0.

WARNING - To provide continued protection against fire or shock hazard, the complete overload relay must be replaced if burnout of the heater element occurs.

NEMA SIZE 2				SIZE J AND K
HEATER PACK SELECTION TABLE				STD TRIP CLASS 20
MOTOR FLA RATING ◆				
FLA DIAL POSITIONS				
A	B	C	D	
3.23	3.90	4.56	5.23	H2008B
4.55	5.50	6.45	7.40	H2009B
6.75	8.17	9.58	11.0	H2010B
9.14	10.8	12.4	14.0	H2011B
14.0	16.9	19.9	22.8	H2012B
18.7	22.7	26.7	30.7	H2013B
23.5	28.5	33.5	38.5	H2014B
29.0	34.0	39.1	44.1	H2015B
39.6	45.5	51.5	57.4	H2016B ●
53.9	60.9	67.9	74.9	H2017B ●

MAXIMUM RATINGS

NEMA SIZE	AMPERES	SIZE	AMPERES
2	45	J	60
		K	73

Use 75°C copper conductors only
Max. Wire Size - 3 AWG

NOTE: After the above referenced settings have been made, rotate the FLA dial **one position clockwise** for these heaters (see table). If less than one position is available, rotate dial to maximum. This note **does not** apply when these heaters are used with adapter base. Catalog No. C306TB1.

NEMA SIZE 3 and 4				SIZE N
HEATER PACK SELECTION TABLE				STD TRIP CLASS 20
MOTOR FLA RATING ◆				
FLA DIAL POSITIONS				
A	B	C	D	
18.0	20.2	22.3	24.5	H2018
24.6	27.6	30.5	33.4	H2019
33.5	37.5	41.5	45.6	H2020
45.7	51.2	56.7	62.1	H2021
62.2	69.7	77.1	84.6	H2022
84.7	94.9	105	115	H2023
106	118	131	144	H2024

MAXIMUM RATINGS

NEMA SIZE	AMPERES	SIZE	AMPERES
3	90	N*	14
4*	135		

Minimum Wire Size - 6 AWG

- **NOTES: Part Winding Starters** - Select heater packs for 50% of the motor FLA
- **Wye Delta Starters** - Select heater packs for 58% motor FLA

◆ For motor FLA values not listed, turn the dial clockwise for higher or counterclockwise for lower ratings.

NEMA SIZE 5				
HEATER PACK SELECTION TABLE				STD TRIP CLASS 20
MOTOR FLA RATING ▲				
FLA DIAL POSITIONS				
A	B	C	D	
34	41	48	54	H2003B
49	59	69	79	H2004B
72	87	103	118	H2005B
107	130	152	174	H2006B
129	156	182	209	H2007B
194	234	274	—	H2008B

MAXIMUM RATINGS

NEMA Size 5 = 270 Amperes Min. Wire Size - 2 AWG

NEMA SIZE 6				
HEATER PACK SELECTION TABLE				STD TRIP CLASS 20
MOTOR FLA RATING ▲				
FLA DIAL POSITIONS				
A	B	C	D	
144	174	205	235	H2005B
215	259	304	348	H2006B
258	312	365	419	H2007B
388	468	547	—	H2008B

MAXIMUM RATINGS

NEMA Size 6 = 540 Amperes

▲ FLA rating marked on heater pack multiplied by a transformation ratio. For motor FLA values not listed, turn the dial clockwise for higher or counterclockwise for lower ratings.

Magnetic Reduced Voltage Starter Classes F600, F700, F890 with C306 Thermal Overload Relay.			
Starter Type	Class	Multiply actual motor full load current by factor below and refer to adjusted full load current column in tables.	Qty. of heaters required per starter
Autotransformer	F600	1	3
Part-Winding	F700	.5	6
Star-Delta	F890	.575	3

PART 8 INSPECTION PRIOR TO ENERGIZING

1. Before energizing the motor control center (MCC), conduct a thorough inspection to make certain that all foreign materials such as tools, scraps of wire and other debris are removed from all units and the structure. Remove any accumulation of dust and dirt with a vacuum cleaner.
2. All circuit connections are tightened at time of assembly by power-driven tools with controlled torque. However, the vibrations experienced in transit may loosen some of these connections. Check at least 1 0% of the total connections for a tight connection. **Should this spot-check reveal some loose connections, it will be necessary to check all connection points.** The connections to be checked include bus hardware, circuit breaker and switch terminals, contactor and relay terminals and terminal blocks. Always check the incoming line connections. Tighten to the torque values shown in Tables 8-1 and 10-4 (page 27).
3. Remove all blocks or other temporary holding means used for shipment from all component devices in the MCC interior.
4. Check the enclosure to see that it has not been damaged so as to reduce electrical spacings.
5. Compare all circuits for agreement with the wiring diagrams which accompany the MCC. Be sure that each motor is connected to its intended starter.
6. Make certain that field wiring is clear of live busses and physically secured to withstand the effects of fault current.
7. Check to determine that all grounding connections are made properly.
8. Check all devices for damage. Make all necessary repairs or replacements, prior to energizing.
9. Manually exercise all switches, circuit breakers, and other operating mechanisms to make certain that they are properly aligned and operate freely.
10. Test any ground-fault protection systems that were furnished.
11. Set any adjustable current and voltage trip mechanisms to the proper values.
12. Ensure that overload relay heater elements are installed and selected to the full-load current shown on the nameplate of each motor.
13. Install power circuit fuses in the fusible switches in accordance with NEC application requirements. Make sure that fuses are completely inserted in the clips provided. Do not attempt to defeat the rejection feature on the fuse clip, when provided.
14. Do not operate a current transformer with its secondary circuit open. Insure current transformer is

TABLE 8-1 DRIVING TORQUE			
Control Wiring:			
Coil Leads			8 lb.-in.
Relays			8 lb.-in.
Push Buttons			8 lb.-in.
Control Fuse Blocks			8 lb.-in.
Auxiliary Contacts			8 lb.-in.
Terminal Blocks			12 lb.-in.
Power Wiring:			
Starters:			
Using Overload Catalog Number	Tightening Torque Load Side		Conductors
C306DN3	20 lb-in		
	Wire Size(AWG)	Torque (lb-in)	Use 75° C copper conductors
C306GN3 and size 2 Contactor)	14-10	35	
	8	40	
	6 - 4	45	
	3 - 2	50	
For Starters	Slotted Head Screw		Use 75°C copper or aluminum conductors
	Wire size(AWG)	Torque (Lb-in)	
	8	40	
	6 - 4	45	
	3 - 2	50	
	Socket Head Screw		
Size 3	Socket Size (In)	Torque (Lb-in)	
	3/16	120	
	1/4	200	
	5/16	250	
Size N and Size 4	275 lb-in		
Size 5 and Size 6	500 lb-in		
Fused Switches:			
30 Amp Fuse Assy			25 lb.-in.
60 Amp Fuse Assy			50 lb.- in.
100 Amp Fuse Assy			50 lb.- in.
200 Amp Fuse Assy			300 lb.- in.
400 Amp Fuse Assy			300 lb.- in.
600 Amp Fuse Assy			300 lb.- in.
BREAKERS- Refer to Torque Values on Breaker Case			
Incoming Line Lugs:			
#2/0- 350 MCM			360 lb.- in.
#2/0- 650 MCM			360 lb.- in.
#2/0- 750 MCM			500 lb.- in.
500-1000 MCM			600 lb.- in.
Bus Bolts:			
All			275 lb.- in.(23lb.-ft.)

connected to a load, or a secondary shorting bar is installed.

15. To prevent possible damage to equipment or injury to personnel, check to insure that all parts and barriers that may have been removed during wiring and installation have been properly reinstalled.
16. Conduct an electrical insulation resistance test make sure that the MCC and field wiring are free from short circuits and grounds. Do this test phase-to-phase, phase-to-ground, and phase-to-neutral with the switches or circuit breakers opened.
17. If the MCC contains a labyrinth vertical bus barrier system, verify the operation of the automatic shutters. See Part 9 for adjustments of this mechanism.
18. Install covers, close doors, and make certain that no wires are pinched and that all enclosure parts are properly aligned and tightened.
19. Turn all circuit breakers and fusible switches to the OFF position before energizing the bus.

PART 9 UNIT INSTALLATION AND ADJUSTMENT

DOOR REMOVAL AND INSTALLATION

All doors on the control center are mounted on pin hinges to facilitate removal for installation and maintenance operations. With the operating handle in the OFF position, rotate the quarter-turn latches, open the door, remove the hinge pins as shown in Figure 26, partially close the door and lift it from the structure. Reverse this procedure for installation.

UNIT REMOVAL AND INSTALLATION

After opening and/or removing the unit door, the control unit is exposed. With a screwdriver, push in on the latch at the top center of the unit and rotate 1/4 turn counterclockwise. **CAUTION** - Units 18" or more high have a retaining brace at the lower edge of each side of the unit frame to add stability in shipping. The shipping braces may be retained or removed after installation; unscrew prior to unit withdrawal. Pull-apart terminal blocks in the vertical wireway must be disengaged (see Figure 27 and page 10) and wiring from the unit to other units, to master terminal blocks or to load devices must be disconnected before the unit is removed. Grasp the unit as shown in Figure 28 and pull it outward. The first inch of travel pulls the stabs free from the vertical bus, and the grounding clip on the side of the unit frame is also disengaged.

To replace a control unit, position the mounting points on the unit frame with the mating guide rails. Slide the

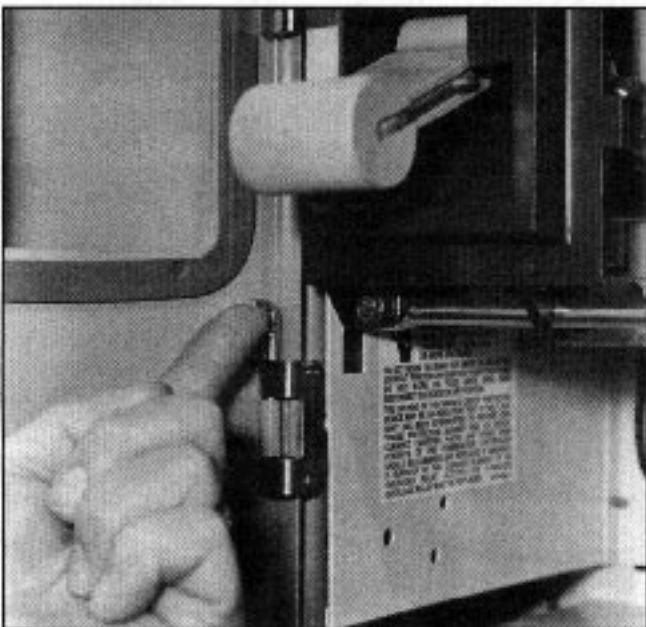

Fig. 26 Hinge Pin Removal

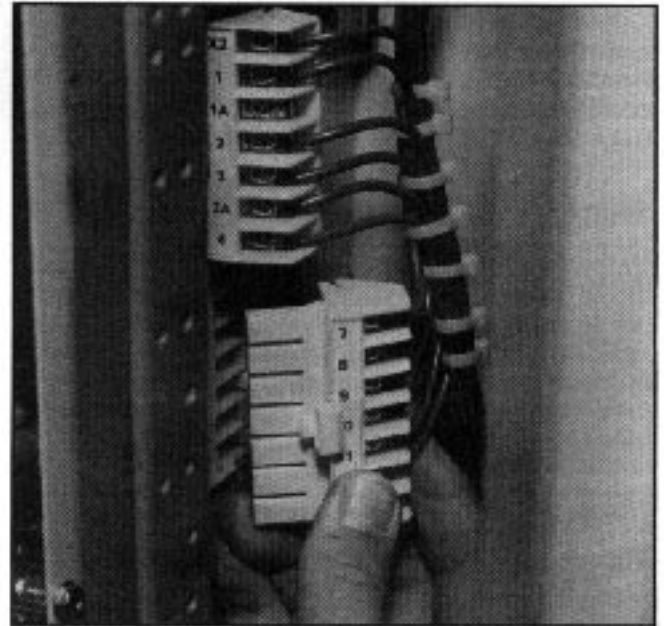

Fig. 27 Disengaging Pull Apart Terminal Blocks

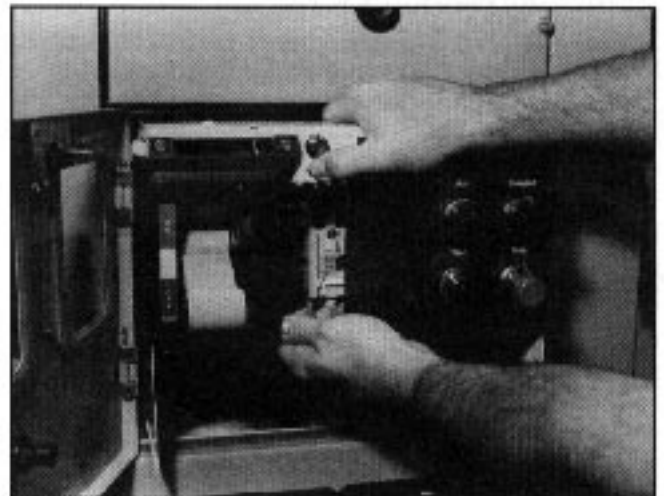

Fig. 28 Withdrawing a Unit

unit inward until all four mounting points are engaged, then move it inward with a quick push. This movement easily overcomes the compression of the stabs as they engage the vertical bus. With the unit in its correct position, the quarter-turn latch is easily engaged by pushing inward and rotating 1/4 turn clockwise.

DETENT POSITION

For maintenance and test purposes, the unit can be partially withdrawn (approximately 1 inches) until the stabs are free of the bus. In this position, the quarter-turn latch can be rotated clockwise to engage the detent position slot; this will secure the unit to ensure the stabs remain disengaged during maintenance. See Figure 29. The latch can be padlocked in this position.

OPERATING HANDLE LINKAGE ADJUSTMENT

Movement of the operating handle in the vertical plane should not be restricted by the handle cavity at either the top or bottom to its travel. Should restriction occur, eliminate it adjusting the length of the operating linkage as shown in Figure 30. Depending on the type of primary disconnect device contained in the control unit, it may be necessary to lengthen or shorten the linkage.

AUTOMATIC SHUTTER TRAVEL ADJUSTMENT

When the optional labyrinth vertical bus barrier is installed in the control center, a shutter is provided to automatically cover the stab openings when a control unit is withdrawn. The shutter is opened by engagement of the left-hand side of the control unit with the shutter arm linkage attached to the left-hand vertical structural members. When the unit is withdrawn free of the linkage, a spring automatically moves the shutter to its closed position. See Figure 31 and Figure 4.

With the control unit removed, the shutter should completely cover the stab openings. If it does not cover the openings, use an adjustable wrench to bend the link arm to the right until the shutter covers the stab openings.

If, on re-insertion of the control unit, interference is felt between the stab assembly at the rear of the unit and the shutter, the engagement of the control unit with the shutter arm linkage is insufficient to fully open the shutter. Use an adjustable wrench to bend the linkage arm inward toward the unit to increase its engagement with the unit. An inward bend of approximately 1/4 inch will provide sufficient additional shutter travel.

INSTALLING PILOT DEVICES

The device panel can accommodate up to six pilot devices such as oil-tight pushbuttons, indicating lights, selector switches and miniature meters. If unused space is available and the addition of other devices is desired, observe the following procedure.

After opening the unit door, loosen the two screws at the top of the device panel. Slide the panel 1/2inch left to permit it to swing down for access. See Figure 32. With the peen end of a ball-peen hammer or with a drift or chisel, remove the desired knockout.

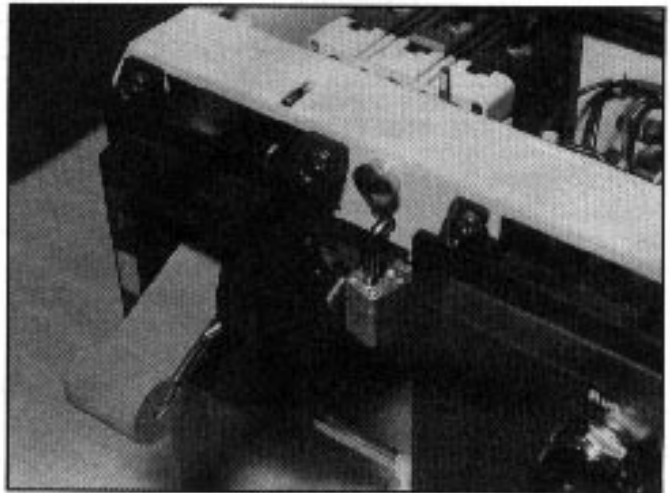

Fig. 29 Unit Locked in Detent Position

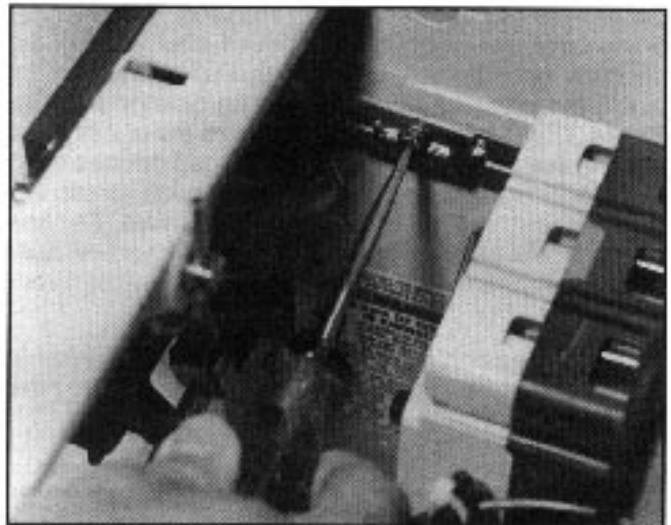

Fig. 30 Operating Handle Linkage Adjustment

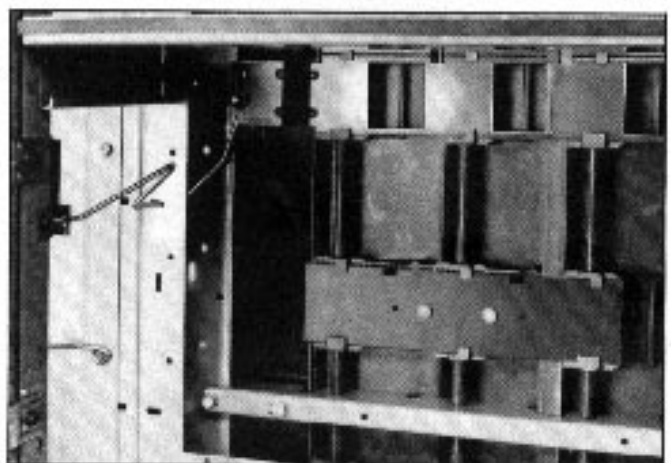

Fig. 31 Shutter Arm Linkage

CAUTION: Brace the panel solidly to avoid breaking the hinge points. Use a knife or small file to remove remaining plastic burrs. Install and wire the new device and re-attach the top of the device panel to the unit.

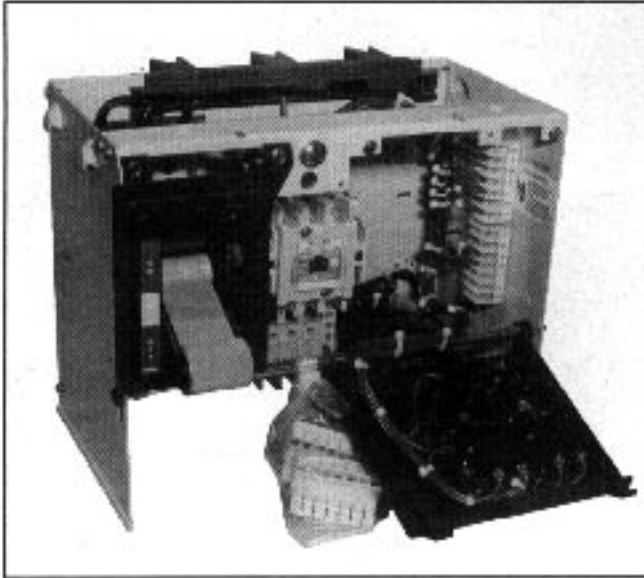

Fig. 32 Unit Device Panel

INSTALLING A NEW UNIT

It is recommended that a new unit be installed in a unit space at the top of a vertical compartment or directly below an existing unit. Material provided with the new unit by the factory includes: a divider pan with integral guide rails, a unit door, hinges, catches and hardware. Observe the following sequence of operations for installation.

1. Remove the existing blank door.
2. Position the new unit door over the open space to ensure the hinges and latches are aligned. If the spaces differ, the hinges and latches on the structure must be re-located to match the unit door hinges and latches. Mount the door, using the hinge pins provided.
3. Install the new divider pan in the notches provided in the rear barrier so that it is aligned with the bottom of the new door. Attach the pan to the vertical structure channels with one thread-forming screw on each side.
4. Remove from the vertical bus barrier the flat plate which covers the stab holes that will align with the stabs on the new unit. If an optional labyrinth vertical bus barrier is in place, install an automatic shutter over the stab cutouts. Follow the instruction sheet provided with the shutter kit.

PART 10 MAINTENANCE

PREVENTIVE MAINTENANCE

Preventive maintenance should be a program, a scheduled periodic action that begins with the installation of the equipment. At that time, specific manufacturer's instruction literature should be consulted, then stored for future reference. Follow-up maintenance should be at regular intervals, as frequently as the severity of duty justifies. Time intervals of one week, or one month, or one year may be appropriate, depending on the duty. It is also desirable to establish specific checklists for each control, as well as a logbook to record the history of incidents. A supply of renewal parts should be obtained and stored.

This control equipment is designed to be installed, operated, and maintained by adequately trained workmen. These instructions do not cover all details, variations, or combinations of the equipment, its storage, delivery, installation, check-out, safe operation, or maintenance. Care must be exercised to comply with local, state, and national regulations, as well as safety practices, for this class of equipment.

Authorized personnel may open a unit door of a motor control center (MCC) while the starter unit is energized. This is accomplished by defeating the mechanical interlock between the operating mechanism and the unit door. A clockwise quarter-turn of the slotted head screw located above operating handle will allow the door to open. See Figure 33.

When servicing and adjusting the electrical equipment, refer to the applicable drawings covering the specific motor control center (MCC) and any other related interconnection drawings. Follow any instructions which may be given for each device. A list of instruction leaflets covering standard components is shown on the back page of this manual. Any of these leaflets may be obtained by contacting your nearest Westinghouse Representative.

General guidelines. The whole purpose of maintaining electrical equipment can be summarized in two rules:

- a. Keep those portions conducting that are intended to be conducting.
- b. Keep those portions insulated that are intended to be insulated.

Good conduction requires clean, tight joints, free of contaminants such as dirt and oxides.

Good insulation requires the absence of carbon tracking and the absence of contaminants such as salt and dust that become hygroscopic and provide an unintended circuit between points of opposite polarity.

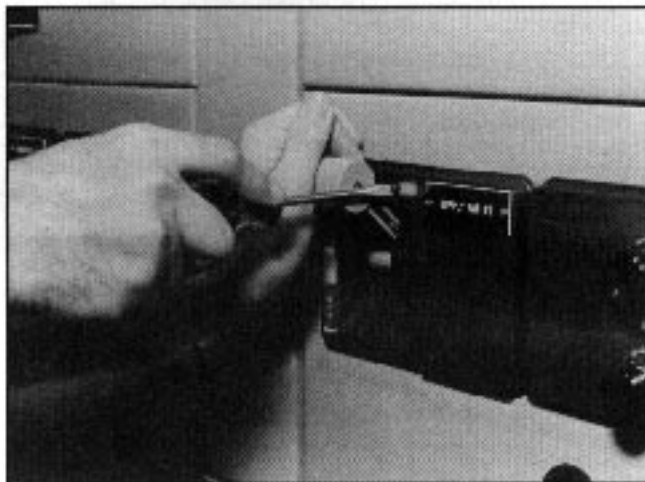

Fig. 33 Defeater Mechanism

CAUTION: Maintenance of control components requires that all power to these components be turned OFF by opening the branch circuit disconnect means and withdrawing the unit to the detent position (see Figure 29) or removing the unit entirely from the MCC. **When units are fully inserted into the MCC, the line side of each disconnect is energized. Do not work on fixed units unless the main disconnect for the MCC is OFF.**

When working on portions of a branch circuit remote from the MCC, lock the disconnect means for that circuit in the OFF position. To positively lock the operating mechanism in the OFF position, a metal locking bar

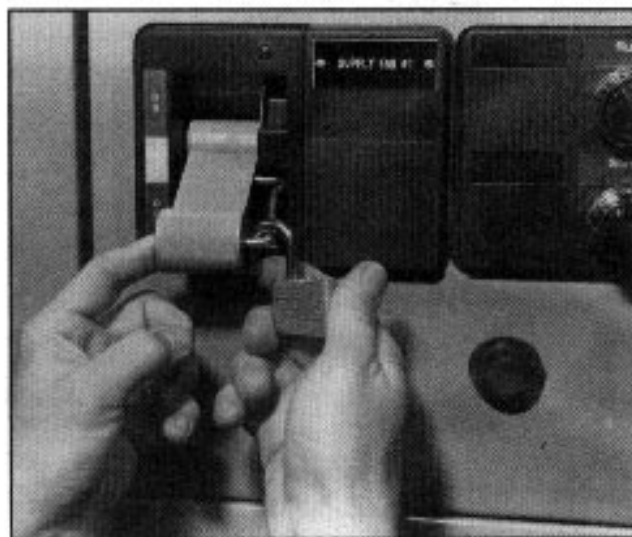

Fig. 34 Locking Out a Disconnect

recessed in the handle may be extended and padlocked with from one to three padlocks. See Figure 34.

With the door open and the disconnect device OFF, the operating handle is mechanically interlocked to prevent inadvertently being pushed ON. To defeat this interlock, the bar on the top of the mechanism should be pushed in slightly, allowing the handle to move upward to the ON position. **WARNING: IF FULLY INSERTED, THE POWER AND CONTROL CIRCUITS WILL BE ENERGIZED.** Padlocking to prevent this handle movement may be accomplished by the same method as described above.

Separate control sources of power must also be disconnected. If control power is used during maintenance, take steps to prevent feedback of a hazardous voltage through a control transformer. Be alert to power factor correction capacitors that may be charged. Discharge them before working on any part of the associated power circuit.

Cleaning. Soot, smoke, or stained areas (other than inside arc chutes), or other unusual deposits, should be investigated and the source determined before cleaning is undertaken. Vacuum or wipe clean all exposed surfaces of the control component and the inside of its enclosure. Equipment may be blown clean with compressed air that is dry and free from oil. (Be alert to built-in oilers in factory compressed air lines!) If air blowing techniques are used, remove arc covers from contactors and seal openings to control circuit contacts that are present. It is essential that the foreign debris be removed from the control center, not merely rearranged. Control equipment should be clean and dry. Remove dust and dirt inside and outside the cabinet without using liquid cleaner. Remove foreign material from the outside top and inside bottom of the enclosure, including hardware and debris, so that future examination will reveal any parts that have fallen off or dropped onto the equipment. If there are liquids spread inside, determine the source and correct by sealing conduit, adding space heaters, or other action as applicable.

Mechanical checks. Tighten all electrical connections. Look for signs of overheated joints, charred insulation, discolored terminals, etc. Mechanically clean to a bright finish (don't use emery paper) or replace those terminations that have become discolored. Determine the cause of the loose joint and correct. Be particularly careful with aluminum wire connections. Aluminum wire is best terminated with a crimp type lug that is attached to the control component. When screw type lugs (marked CU/AL) are used with aluminum wire, joint should be checked for tightness every 200 operations of the device.

Wires and cables should be examined to eliminate any chafing against metal edges caused by vibration, that could progress to an insulation failure. Any temporary wiring should be removed, or permanently secured and diagrams marked accordingly.

The intended movement of mechanical parts, such as the armature and contacts of electromechanical contactors,

and mechanical interlocks should be checked for freedom of motion and functional operation.

Wrap-up. Check all indicating lamps, mechanical flags, doors, latches, and similar auxiliaries and repair, if required.

Log changes and observations into record book before returning equipment into service. Do not remove any labels or nameplates. Restore any that are damaged.

SLIDER OPERATOR MECHANISM- (6-inch Units) (See Figure 35)

The following features are found on 6-inch units with circuit breaker operators.

A. Door Interlock

The operator mechanism is factory adjusted and normally does not need field adjustment. The door interlock mechanism engages a hook that is mounted to the welded bracket. This allows the unit door to open when the operator handle is in the "off" (right) position. With the handle in the "on" (left) position, the door is interlocked and should not open. If the door hook and the mechanism do not engage properly, the positioning of the door hook on the bracket may need adjustment. The door hook can be adjusted left or right by loosening the screw (see photograph). After adjustment, tighten screw to 201b./in. [2.2 N-m]. See Figure 38 insert.

B. Defeater Screw

Turning the defeater screw clockwise allows you to open the unit door (access to the panel mounted components) with the operator handle (padlocked or not) in the "on" (left) position.

C. Padlocking (See Figures 36, 37 & 38)

The operator handle can be padlocked in the "off" position with up to three 3/8" [1 9.5 mm](Max.) shank padlocks.

To provide for padlocking the circuit breaker operator in the "on" position, drill the appropriate size hole through the drill point located on the operator mechanism.

D. Unit Interlock

The unit interlock is provided to assure that the unit circuit breaker is:

- Open before the stab clips can contact the vertical bus.
- Open before the stab clips can be disengaged from the vertical bus.

The unit interlock and bracket does not need field adjustment. The interlock bracket will be adjusted to almost touch the side of the unit interlock rod when the operator is in the "on" position.

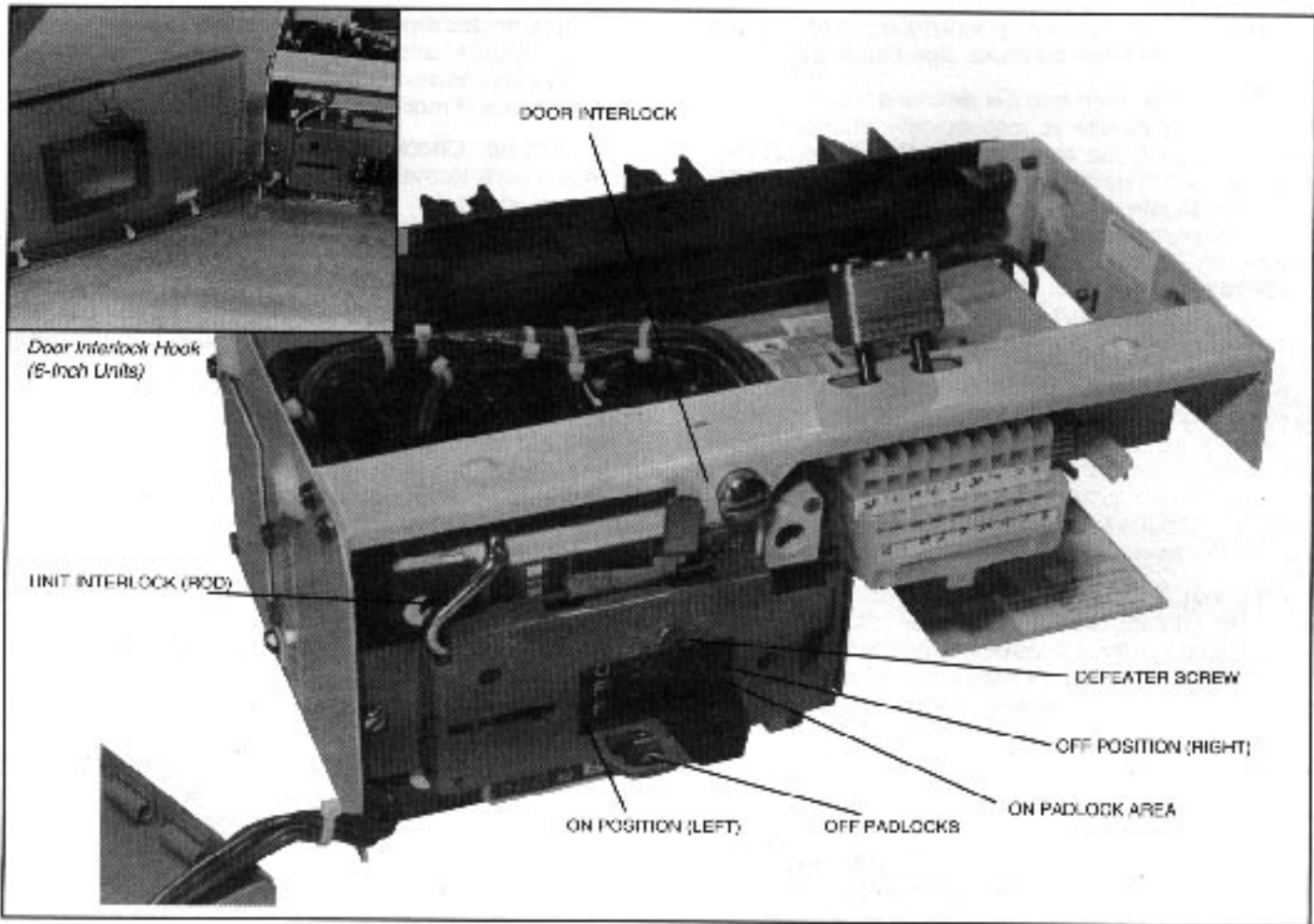

Fig. 35 6-inch Breaker Unit Slider Operator Mechanism

MCC Slider Operator Mechanism Padlocking

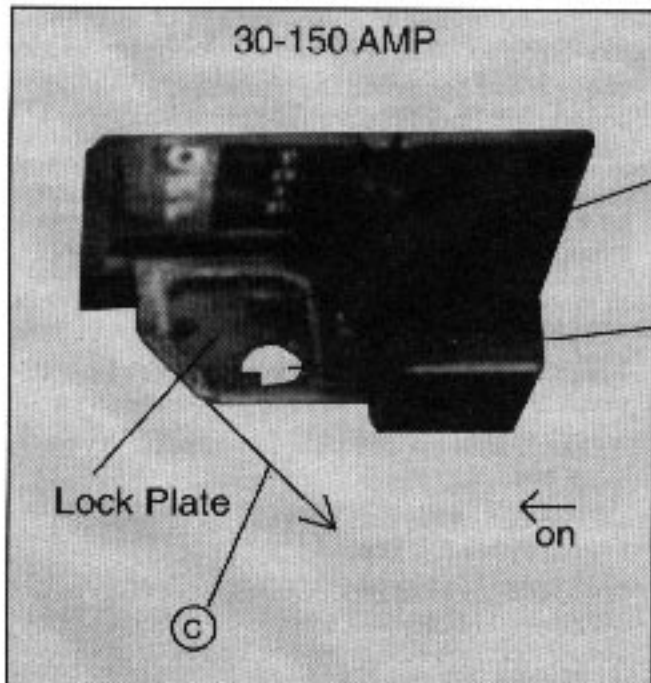

Fig. 36

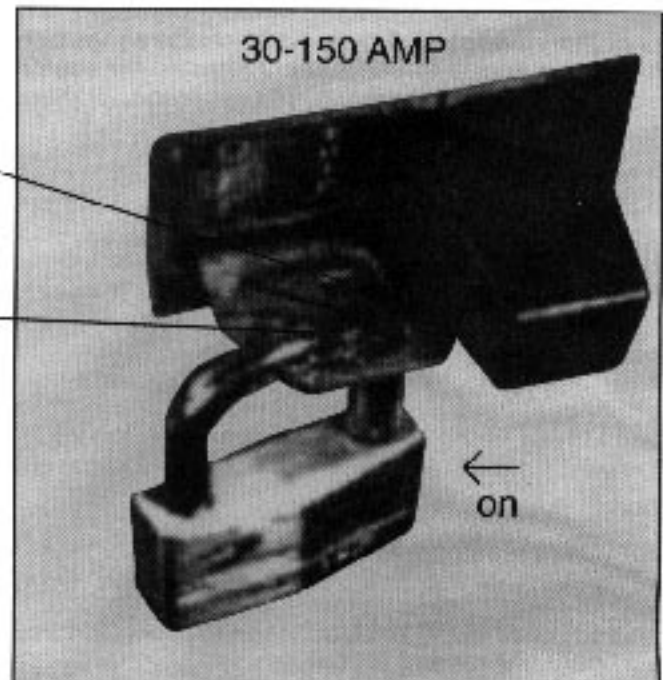
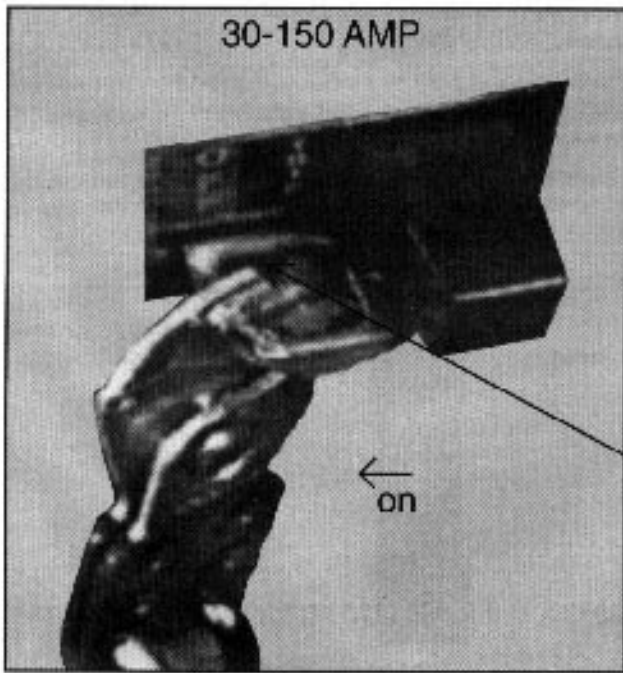

Fig. 37



(A)

Rectangular slot for scissors

(B)

One 1/411 or 5/16" diameter padlock hasp.

(C)

Rotate lock plate for one to three 3/8" diameter padlock hasp locks.

(A)

Fig. 38

CONTACT WEAR AND REPLACEMENT

Contractors are subject to both mechanical and electrical wear during their operation. In most cases mechanical wear is insignificant. The erosion of the contacts is due to electrical wear. During arcing, material from each contact is vaporized and blown away from the useful contacting surface.

A critical examination of the appearance of the contact surfaces and a measurement of the remaining contact overtravel will give the user the information required to get the maximum contact life.

OVERTRAVEL MEASUREMENT

Contact life has ended when the overtravel of the contacts has been reduced to .020 inch.

Overtravel of the contact assembly is that part of the stroke which the moving contacts would travel after touching the fixed contacts if they were not blocked from movement by the fixed contacts.

A method of measuring overtravel is as follows:

- A. Place a .020 inch feeler gauge between the armature and magnet, with the armature held tightly against the magnet.

- B. Check continually in each phase, i.e., determine if circuit from terminal-to-terminal for each pole is open under these conditions.
- C. If there is continuity through all phases, the remaining overtravel is sufficient. If there is not continuity through all phases, replace all stationary and moving contacts plus moving contact overtravel springs. After replacing parts, manually operate contactor to be sure binding does not occur.

CONTACTOR TROUBLESHOOTING CHART

Defect	Cause	Remedy
Short contact life	Low contact force	Adjust overtravel, replace contacts, and replace contact springs as required to correct contact force.
	Contact bounce on opening or closing	Correct improper voltage applied to coil. Correct any mechanical defects or misalignment.
	Abrasive dust on contacts	Do not use emery cloth to dress contacts.

CONTACT EVALUATION

Time of Service	Contact Appearance
New	The new contact has a uniform silver color.
Start of Service	The contact surface will have a blue coloring. The geometric form of the contact is unchanged. The sharp outer corners will be rounded with small silver beads. (See Figure 39.)
Intermediate Service to End of Service Life	The coloring changes to brown or black with distributed small silvery white areas. The surface has a finely chiselled appearance. Material transfer causes small peaks and valleys in the contact button surface. (See Figure 40.)

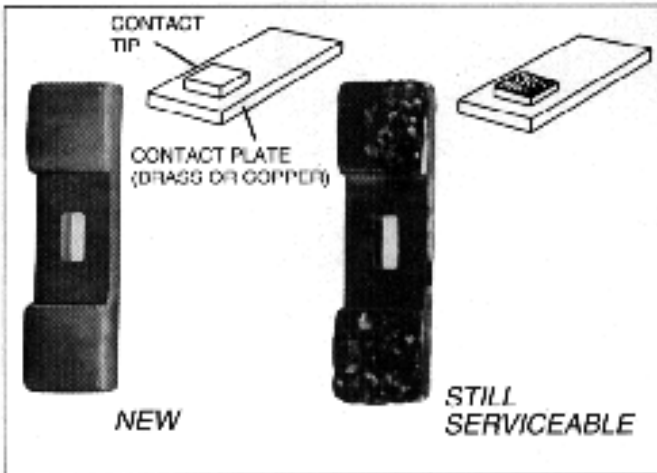

Fig. 39 Normal Service Wear

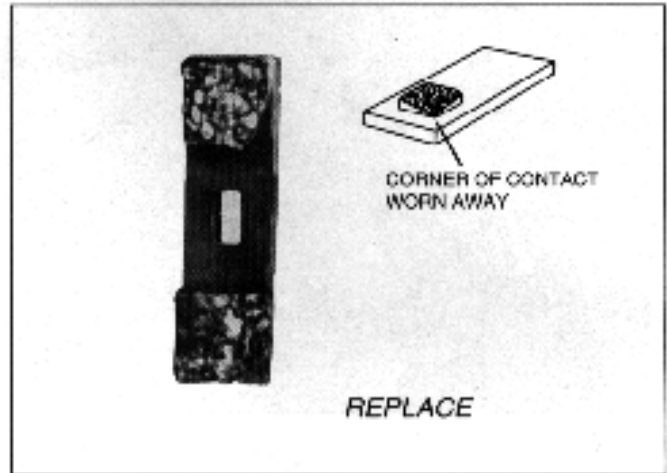

Fig. 40 End of Service Life

ABNORMAL WEAR CONDITIONS

Contact Appearance	Cause
Curling and Separation of Corner of Contact	Curling is usually a result of service that produces very high heat, as under jogging or inching duty.
Irregular Contour or Slantwise Wear	One corner of a contact may wear more quickly than the other three corners. This wear is normally due to misalignment of the moving and stationary contacts. Contacts should be replaced if it is apparent that one contact is nearly making direct contact with the contact carrier.
Large Beads of Silver On Edges of Contacts	Breaking an excessive current.
Welded Spot (Core of Smooth, Shining Silver Surrounded by a Roughened Halo)	Making an excessive current. High frequency of operation, i.e., jogging.

CONTACTOR TROUBLESHOOTING CHART (Cont.)

Defect	Cause	Remedy
Overheating	Ambient temperature is too high	Reduce load. Provide better ventilation. Relocate starter. Use larger block and run larger conductors between contactor and terminal block.
	Line and/or cables are too small	
Welding of contacts	Excessive contact bounce on closing	Correct coil overvoltage condition
	Jogging duty is too severe	Reduce jogging cycle
	Excessive inrush current	Motor has locked rotor code letter greater than G. Most contactors are designed for motors with code letters A through G. therefore, use larger contactor. check factory for weld-resistant contact material.
	Vibration in starter mounting	Move starter to location having less shock and vibration. Insulate starter from shock and vibration. Provide more rigid support for starters

MAINTENANCE OF MOTOR CONTROLLERS AFTER A FAULT†

In a motor branch circuit which has been properly installed, coordinated and in service prior to the fault, opening of the branch-circuit short-circuit protective device (fuse, circuit breaker, motor short-circuit protector, etc.) indicates a fault condition in excess of operating overload. This fault condition must be corrected and the necessary repairs or replacements made before reenergizing the branch circuit.

It is recommended that the following general procedures be observed by qualified personnel in the inspection and repair of the motor controller involved in the fault.

Procedure. Caution: All inspections and tests are to be made on controllers and equipment which are deenergized, disconnected and isolated so that accidental contact cannot be made with live parts and so that all plant safety procedures will be observed.

Enclosure. Substantial damage to the unit door or frame such as deformation, displacement of parts or burning, requires replacement of the entire unit.

Circuit breaker. Examine the unit interior and the cir-

cuit breaker for evidence of possible damage. If evidence of damage is not apparent, the breaker may be reset and turned ON. If it is suspected that the circuit breaker has opened several short-circuit faults or if signs of circuit breaker deterioration appear within the enclosure, the circuit breaker should be replaced.

Disconnect switch. The external operating handle of the disconnect switch must be capable of opening the switch. If the handle fails to open the switch or if visual inspection after opening indicates deterioration beyond normal wear and tear, such as overheating, contact blade or jaw pitting, insulation breakage or charring, the switch must be replaced.

Fuse holders. Deterioration of fuse holders or their insulating mounts requires their replacement.

Terminals and internal conductors. Indications of arcing damage and/or overheating such as discoloration and melting of insulation require the replacement of damaged parts.

Contactors. Contacts showing heat damage, displacement of metal, or loss of adequate wear allowance require replacement of the contacts and the contact springs. If deterioration extends beyond the contacts, such as binding in the guides or evidence of insulation

Reproduced by permission of the National Electrical Manufacturers Association from NEMA Standards Publication No. ICS 2-1978 (R1983), Industrial Control Devices, Controllers and Assemblies, copyright 1978 by NEMA.

damage, the damaged parts or the entire contactor must be replaced.

Overload relays. If burnout of the current element of an overload relay has occurred, the complete overload relay must be replaced. Any indication that an arc has struck and/or any indication of burning of the insulation of the overload relay also requires replacement of the overload relay.

If there is no visual indication of damage that would require replacement of the overload relay, the relay must be electrically or mechanically tripped to verify the proper functioning of the overload relay contact(s).

Return to service. Before returning the controller to service, checks must be made for the tightness of electrical connections and for the absence of short circuits, grounds and leakage.

All equipment enclosures must be closed and secured before the branch circuit is energized.

RENEWAL PARTS

When ordering renewal control center parts, give the complete nameplate reading. Always give the name of the part wanted, the part, catalog or style number of the individual apparatus on which it is to be used, and the order number of the complete motor control center.

Control center renewal parts identified by part or style number are detailed in Cutler-Hammer Renewal Parts Data. The nomenclature to identify these parts is shown in figures 2 and 41. The most common renewal parts of components are shown in Table 10-1.

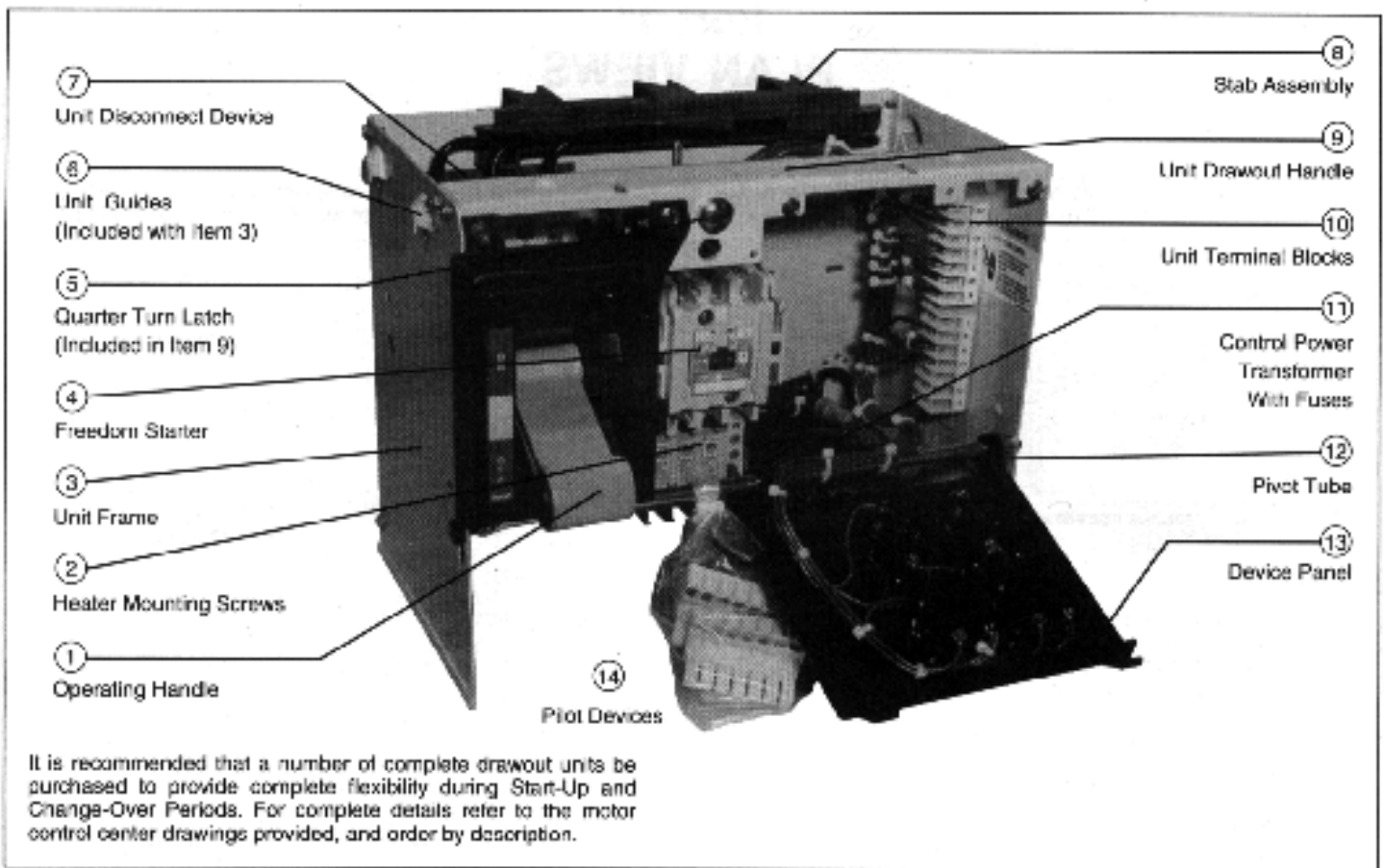

Fig. 41 Control Center Unit Nomenclature

STARTER TYPE

Unit Catalog Number Destination (Class)

Description	Disconnect Means:		
	Fusible	Circuit Breaker	Circuit Breaker With Current Limiter
Full Voltage, Non-Reversing	F204	F206	F207
Full Voltage, Reversing	F214	F216	F217
Reduced Voltage, Autotransformer Type	F604	F606	F607
Reduced Voltage, Part Winding Type	F704	F706	F707
Reduced Voltage, Closed Transition Star Delta	F894	F896	F897
Full Voltage, Non-Reversing, 2 Speed, 2 Windings	F954	F956	F957
Full Voltage, Non-Reversing, 2-Speed, 1 Windings	F944	F946	F947

Part 11 PLAN VIEWS

**20 Inches Wide, 16 Inches Deep
Front Mounted Only (4710A30)**

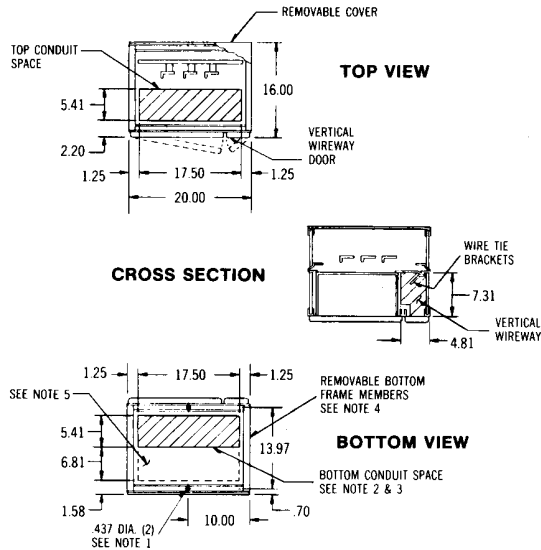

1. Minimum length of anchor bolt 2 inches (.36-16 recommended.)
 2. Recommended maximum conduit height above floor line 3.50 inches.
 3. Maximum conduit space with channel sills 17.5 x 9.73 inches.
 4. For multiple structure assemblies either one or both of these members are removed to provide maximum un-restricted conduit space at bottom.
 5. This conduit space not recommended when neutral bus required. Otherwise available.
- See side View A, far right for vertical dimensions.

**20 Inches Wide, 21 Inches Deep
Front Mounted Only (4710A31)**

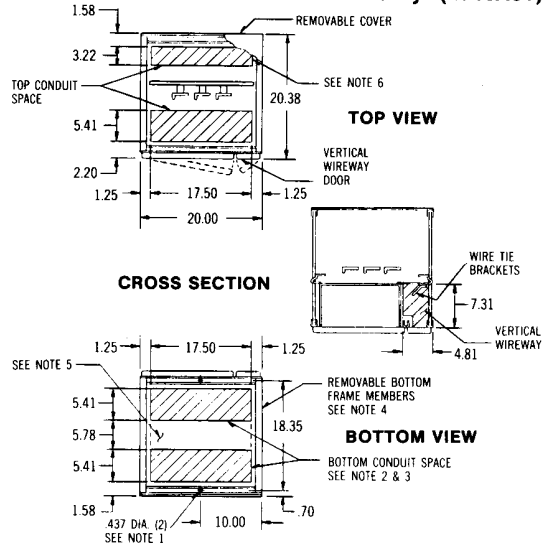

1. Minimum length of anchor bolt 2 inches (.36-16 recommended.)
 2. Recommended maximum conduit height above floor line 3.50 inches.
 3. Maximum conduit space with channel sills 17.5 x 14.11 inches.
 4. For multiple structure assemblies either one or both of these members are removed to provide maximum un-restricted conduit space at bottom.
 5. This conduit space not recommended when neutral bus required. Otherwise available.
 6. Top rear conduit space not recommended for conduit entry in FMO structure.
- See side View A, far right for vertical dimensions.

**24 Inches Wide, 16 Inches Deep
Front Mounted Only (4710A33)**

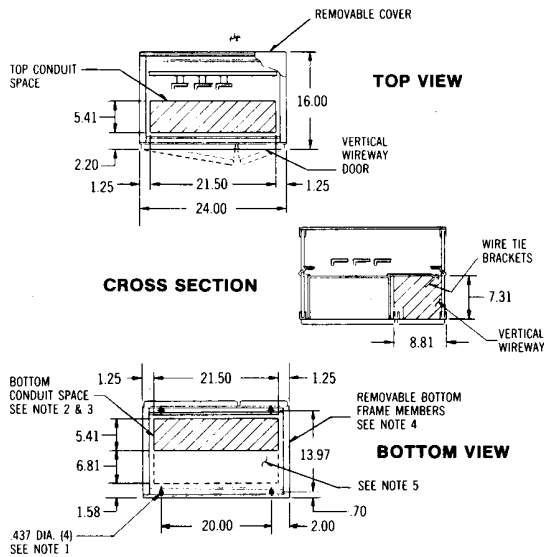

1. Minimum length of anchor bolt 2 inches (.36-16 recommended.)
 2. Recommended maximum conduit height above floor line 3.50 inches.
 3. Maximum conduit space with channel sills 21.5 x 9.73 inches.
 4. For multiple structure assemblies either one or both of these members are removed to provide maximum un-restricted conduit space at bottom.
 5. This conduit space not recommended when neutral bus required. Otherwise available.
- See side View A, far right for vertical dimensions.

**24 Inches Wide, 21 Inches Deep
Front Mounted Only (4710A34)**

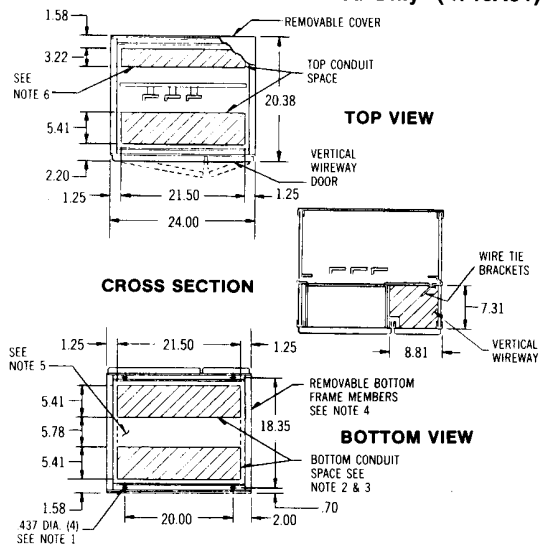

1. Minimum length of anchor bolt 2 inches (.36-16 recommended.)
 2. Recommended maximum conduit height above floor line 3.50 inches.
 3. Maximum conduit space with channel sills 21.5 x 14.11 inches.
 4. For multiple structure assemblies either one or both of these members are removed to provide maximum un-restricted conduit space at bottom.
 5. This conduit space not recommended when neutral bus required. Otherwise available.
 6. Top rear conduit space not recommended for conduit entry in FMO structure.
- See side View A, far right for vertical dimensions.

Effective December, 1994

**20 Inches Wide, 21 Inches Deep
Front and Rear Mounted (4710A32)**

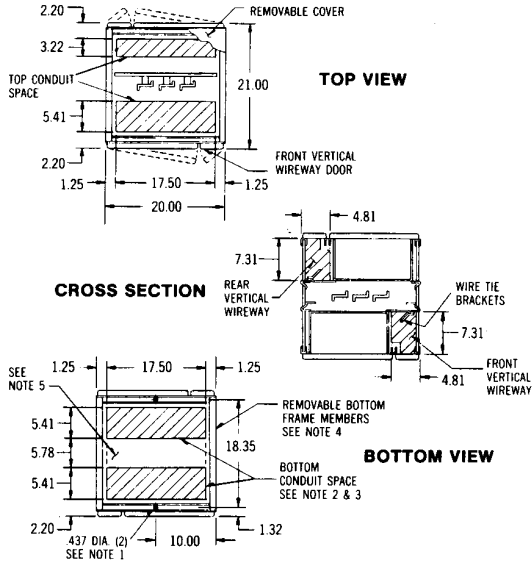

1. Minimum length of anchor bolt 2 inches (.36-16 recommended.)
2. Recommended maximum conduit height above floor line 3.50 inches.
3. Maximum conduit space with channel sills 17.5 x 14.11 inches.
4. For multiple structure assemblies either one or both of these members are removed to provide maximum un-restricted conduit space at bottom.
5. This conduit space not recommended when neutral bus required. Otherwise available.

See side View B, far right for vertical dimensions.

**10 Inches Wide, 16 or 21 Inches Deep
Transition Structures (4710A35/6)**

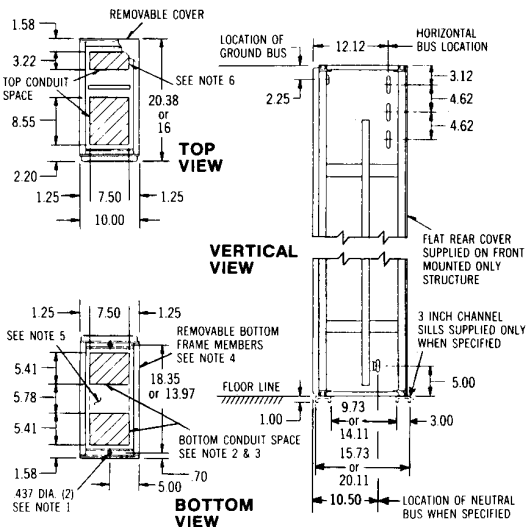

1. Minimum length of anchor bolt 2 inches (.36-16 recommended.)
2. Recommended maximum conduit height above floor line 3.50 inches.
3. Maximum conduit space with channel sills 7.5 x 14.11 inches in 21" deep structure, 7.5 x 9.73 inches in 16" deep structure.
4. For multiple structure assemblies either one or both of these members are removed to provide maximum un-restricted conduit space at bottom.
5. This conduit space not recommended when neutral bus required. Otherwise available.
6. Top rear conduit space not recommended for conduit entry in 21" deep FMO structure. Space not available in 16" deep structure.

SIDE VIEWS

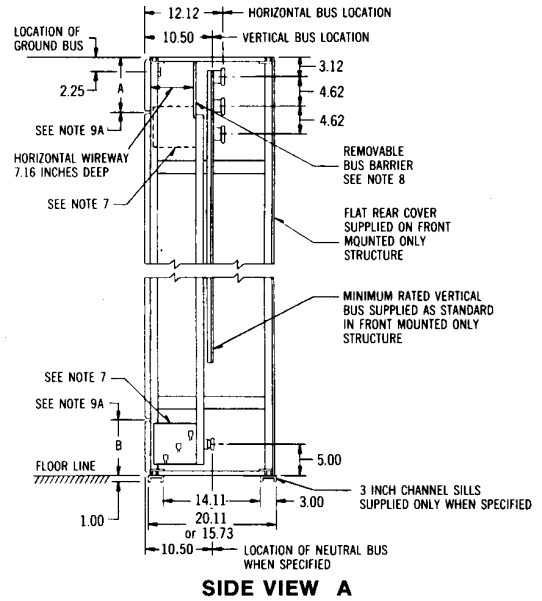

SIDE VIEW A

Common Notes

7. Master terminal block assembly furnished for Type C wiring only. When location not specified, MTB supplied at the bottom.
8. Rear horizontal bus barrier not supplied with front mounted only structure.
9. Standard structure arrangement
 - (a) In Front
 - Without MTB: A & B = 9"
 - With MTB at bottom: A & B = 9"
 - With MTB at top: A = 15", B = 3"
 - (b) In Rear
 - Without MTB: C = 0, D = 72", E = 3"
 - With MTB at bottom: C = 0, D = 66", E = 9"
 - With MTB at top: C = 12", D = 60", E = 3"

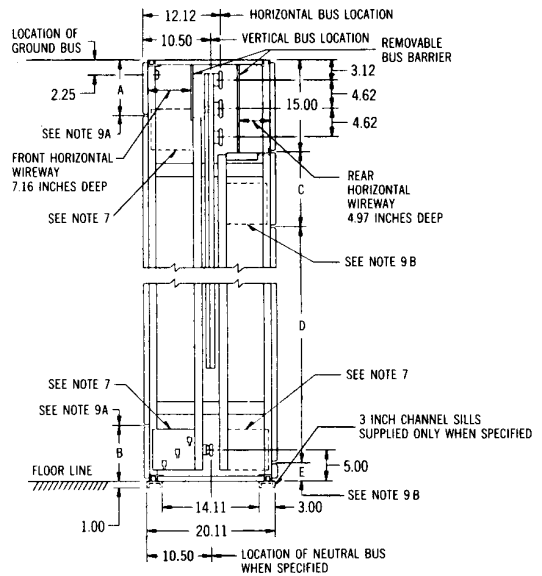

SIDE VIEW B

RELATED INSTRUCTION LEAFLETS

Starters:

Size 5, non-reversing and reversing, vacuum	I.L. 17087
Size 6, non-reversing and reversing, vacuum	I.L. 17089
Accutrol 150, 5-50 HP	I. L. 8730
Accutrol 300, 7.5-600 HP	I.L. 8720

Contactors:

Size 5, non-reversing and reversing, vacuum	I.L. 16999
Size 6, non-reversing and reversing, vacuum	I.L. 17088

Metering:

IQ Data Plus	TD 17195
--------------------	----------

Circuit Breakers:

Series C, F-frame	I.L. 29CIO1
Series C, J-frame	I.L. 29CIO3
Series C, K-frame	1. L. 29C 1 04
Series C, L-frame	1. L. 29C 1 05
Series C, N-frame	1. L. 29C 1 06
Series C, R-frame	I.L. 29CIO7
Transfer Switches	I.L. 14477
