



Horizontal Pump System Husky Alliance

(Canada)

Reference:	HPS/RFQ-120242
Version:	A
Release Date:	22-Dec-2008
EDMS UID:	
Produced:	10-Sept-2009
Owner:	Husky Energy
(Canada)	

Private

Intentionally Blank

Private

Copyright © 2008 Schlumberger, Unpublished Work. All rights reserved.

Legal Information

Copyright © 2008 Schlumberger, Unpublished Work. All rights reserved.

This work contains the confidential and proprietary trade secrets of Schlumberger and may not be copied or stored in an information retrieval system, transferred, used, distributed, translated or retransmitted in any form or by any means, electronic or mechanical, in whole or in part, without the express written permission of the copyright owner.

Trademarks & Service marks

Schlumberger, the Schlumberger logotype, and other words or symbols used to identify the products and services described herein are either trademarks, trade names or service marks of Schlumberger and its licensors, or are the property of their respective owners. These marks may not be copied, imitated or used, in whole or in part, without the express prior written permission of Schlumberger. In addition, covers, page headers, custom graphics, icons, and other design elements may be service marks, trademarks, and/or trade dress of Schlumberger, and may not be copied, imitated, or used, in whole or in part, without the express prior written permission of Schlumberger.

A complete list of Schlumberger marks may be viewed at the Schlumberger Oilfield Services Marks page: <http://markslist.slb.com>

Private

Copyright © 2008 Schlumberger, Unpublished Work. All rights reserved.

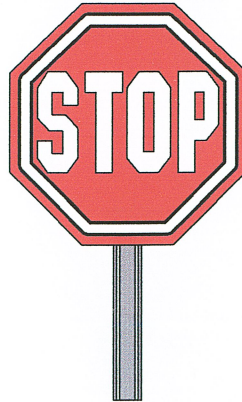

Read The Following Before Starting This Equipment

DANGER

ALWAYS ground this equipment correctly
NEVER operate this equipment without safety guards
NEVER attempt to operate this piece of equipment at a ZERO FLOW condition
FOLLOW LOCK-OUT / TAG-OUT procedures when servicing this unit
DO NOT use piping or fittings that are damaged or have inadequate pressure ratings with this equipment

WARNING

ALWAYS follow correct start up procedure (see operators manual)
ALWAYS maintain pump flow and pressure within its recommended operating range (see operators manual)
CHECK that shaft clamps are removed prior to starting
ALWAYS lift from designated lifting points only
ALWAYS comply with recommended service intervals and use recommended lubricants
FAILURE to follow start up and operating procedures may void warranty

ADVISORY

NEVER operate this equipment without shutdown systems in place
USE a check valve (non-return valve) on the discharge to avoid 'back spinning' the pump
ALWAYS adjust valves slowly
IF OPERATING IN COLD CONDITIONS BEWARE OF LIQUID FREEZING IN PUMP

SLB QHSE STANDARDS



SLB QHSE S001.
Journey Management
and Driving



SLB QHSE S002. Event
Reporting and
Management



SLB QHSE S003.
Personal Protective
Equipment



SLB QHSE S004.
Business Continuity,
Emergency and Crisis
Management



SLB QHSE S005.
Training and Competency



SLB QHSE S006. Health



SLB QHSE S007.
Management System
Audits

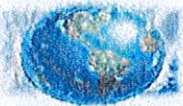

SLB QHSE S008.
Environment



SLB QHSE S009. Loss
Prevention Teams



SLB QHSE S010.
Management of Change
and Exemption



SLB QHSE S011.
Employee and Asset
Security



SLB QHSE S012.
Contracting



SLB QHSE S013.
Mechanical Lifting



SLB QHSE S014.
Pressure



SLB QHSE S015.
H2S



SLB QHSE S016.
Fire Prevention and
Mitigation



SLB QHSE S017.
Injury Prevention



SLB QHSE S018.
Radiation



SLB QHSE S019.
Explosives



SLB QHSE S020. Hazard
Analysis and Risk Control



SLB QHSE S021. Data
Quality

Schlumberger



**Power you can count on
anytime, anywhere**



**RedaHPS Horizontal
Surface Pumping Systems**



The RedaHPS* horizontal multistage surface pumping system delivers power you can count on for your surface pumping applications.

The RedaHPS system has proved to be a long-term, cost-effective, low-maintenance alternative to conventional high-pressure pumps. RedaHPS pumps provide years of problem-free service in any environment, with packages customized for the harshest climates. From intense desert heat to extreme Arctic cold, our pumps keep the fluid moving.

The RedaHPS system uses the REDA* electric submersible pump (ESP) technology originally designed for harsh downhole pumping conditions.

These pumps offer exceptional performance in even the toughest operating environment and are designed to provide services for a wide range of surface applications. The durable and flexible units operate in applications varying from high-pressure water injection and crude-oil transfer to lean amine service, liquid natural gas (LNG) pumping, and refinery operations. No matter what the challenge, RedaHPS surface pumps perform—anytime, anywhere.

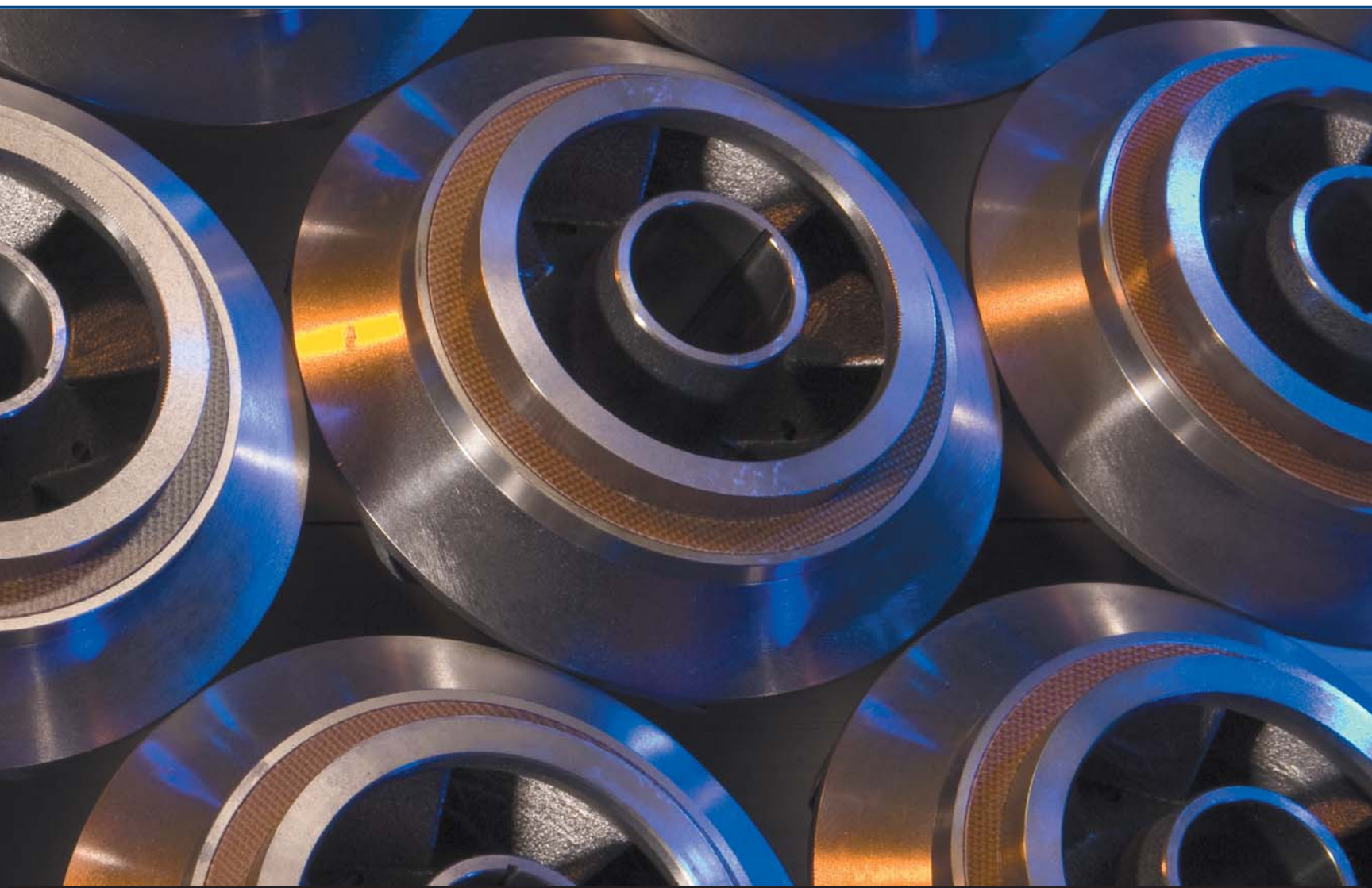

A POWERFUL PACKAGE

- 2,000 hp in a single unit
- 18,000 ft.lbf of thrust
- 1,850 galUS/min of flow
- 6,000 psi pressure rating

POCKET

A tradition of **dependability** and **power**

The RedaHPS horizontal multistage pump has a rich history of continuous product improvement, owing largely to quality assurance practices that were put in place soon after the REDA electric submersible pump system was awarded the original patent for ESPs worldwide. Since the 1940s, the RedaHPS pump series has been a reliable, cost-effective, flexible alternative to conventional pumping systems. The RedaHPS system is used today in a wealth of applications around the globe, from simple water injection and disposal to more complex refinery and offshore crude oil transfer and refinery pumping service. Cost-competitive and customizable for your specific needs, the RedaHPS equipment requires less inventory and delivery time than conventional equipment and has a lower life-cycle cost, thanks to minimized downtime and low maintenance requirements. The result is increased mean time between failures (MTBF), giving you a powerful pumping system you can count on.

■ Tradition

The RedaHPS series is the industry leader in ESP surface-style pumping equipment. With more than 60 years of experience, Schlumberger continues to build on a tradition of dependability and power.

■ Dependability

The RedaHPS system incorporates flexible features and API 610 designs that maximize overall pump run life and minimize downtime. The pump's modular design enables easy modification whenever needed—all major components can be exchanged within 2 to 3 hours.

■ Power

The RedaHPS pumping system can deliver up to 2,000 hp in a single unit. Alternatively, multiple units can be configured in series or parallel to provide redundancy, additional volume, or pressure.

Cost-competitive and customizable for your specific needs

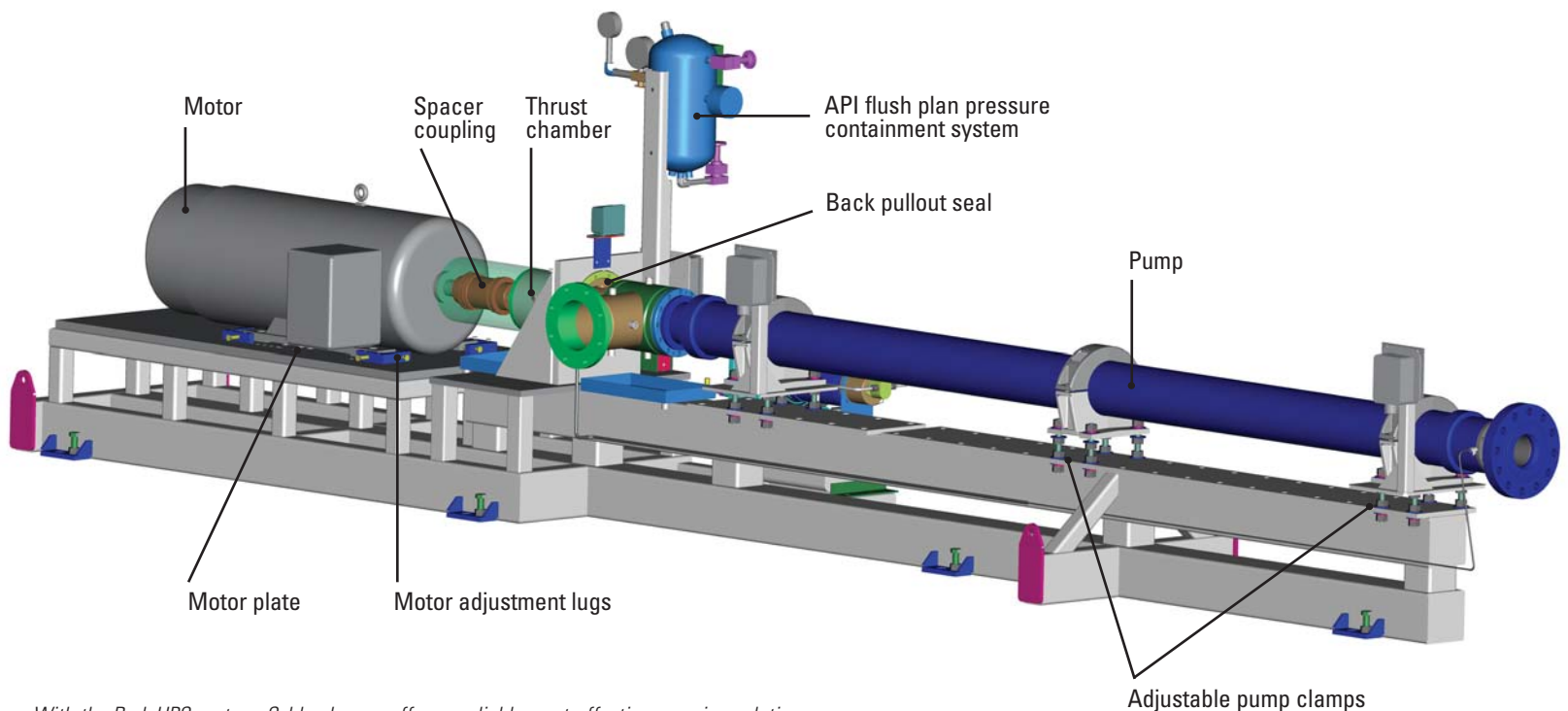

With the RedaHPS system, Schlumberger offers a reliable, cost-effective pumping solution that is delivered quickly and is flexible enough to be modified in the field. Features are built in to provide a low-maintenance, flexible, cost-effective system, including back pullout seals, spacer coupling, adjustable pump clamps, and an adjustable motor plate.

Reliable, flexible, modular design

APPLICATIONS

- Water injection and disposal
- Reservoir pressure maintenance
- Power fluid boost for hydraulic lift systems
- Coalbed methane fracturing
- Crude oil transfer
- Geothermal injection
- Effluent disposal
- Mine dewatering
- Lean amine charge
- Salt dome leaching
- LNG boosting and transfer
- Carbon dioxide boosting
- Boiler feedwater
- Pipeline boosting

PROVEN RELIABILITY AROUND THE WORLD

RedaHPS equipment is effective in both land-based and offshore installations. From the deserts of the Middle East to the tundra of Siberia and from the underground mines of Canada to the jungles of South America, RedaHPS units are working 24/7, giving years of dependable, trouble-free service.

SYSTEM FEATURES MEET A VARIETY OF NEEDS

The RedaHPS system is application-ready. Low-maintenance centrifugal pumps, boasting a field-friendly modular design, offer competitive pricing and delivery times for an array of applications. The API back-pullout feature means quick seal changes—which minimize downtime and protect the environment—and higher nozzle load capacity, which delivers on the promise of reliability and improved productivity.

In addition, the unit offers single, double, or triple thrust-bearing designs within one housing, with load capacity up to 18,000 ft.lbf for increased thrust loads. Optional motor frames and seal designs, adjustable clamps, and modular components set the RedaHPS equipment apart from conventional API 610 pumps and easily accommodate future modifications and upgrades. Minimal noise, vibration, and emissions make the RedaHPS pump a lower environmental risk as well.

MANUFACTURING AND TESTING CENTER REDUCES LEAD TIMES AND COSTS

Rigorous testing at the Bartlesville Product Center (BPC) ensures that the RedaHPS system meets design specifications and exceeds industry standards. With its emphasis on quality, cost, and delivery, the new facility offers manufacturing and testing under one roof, significantly reducing production lead times and trimming costs. Using generators capable of 4 MW, the BPC can assemble and test units up to 2,000 hp at full load.

Quality at the source

Stringent testing of RedaHPS pumping equipment conducted at the BPC surpasses industry standards and assures production of a system that can reliably meet a host of customer needs.



RedaHPS Horizontal Surface Pumping Systems

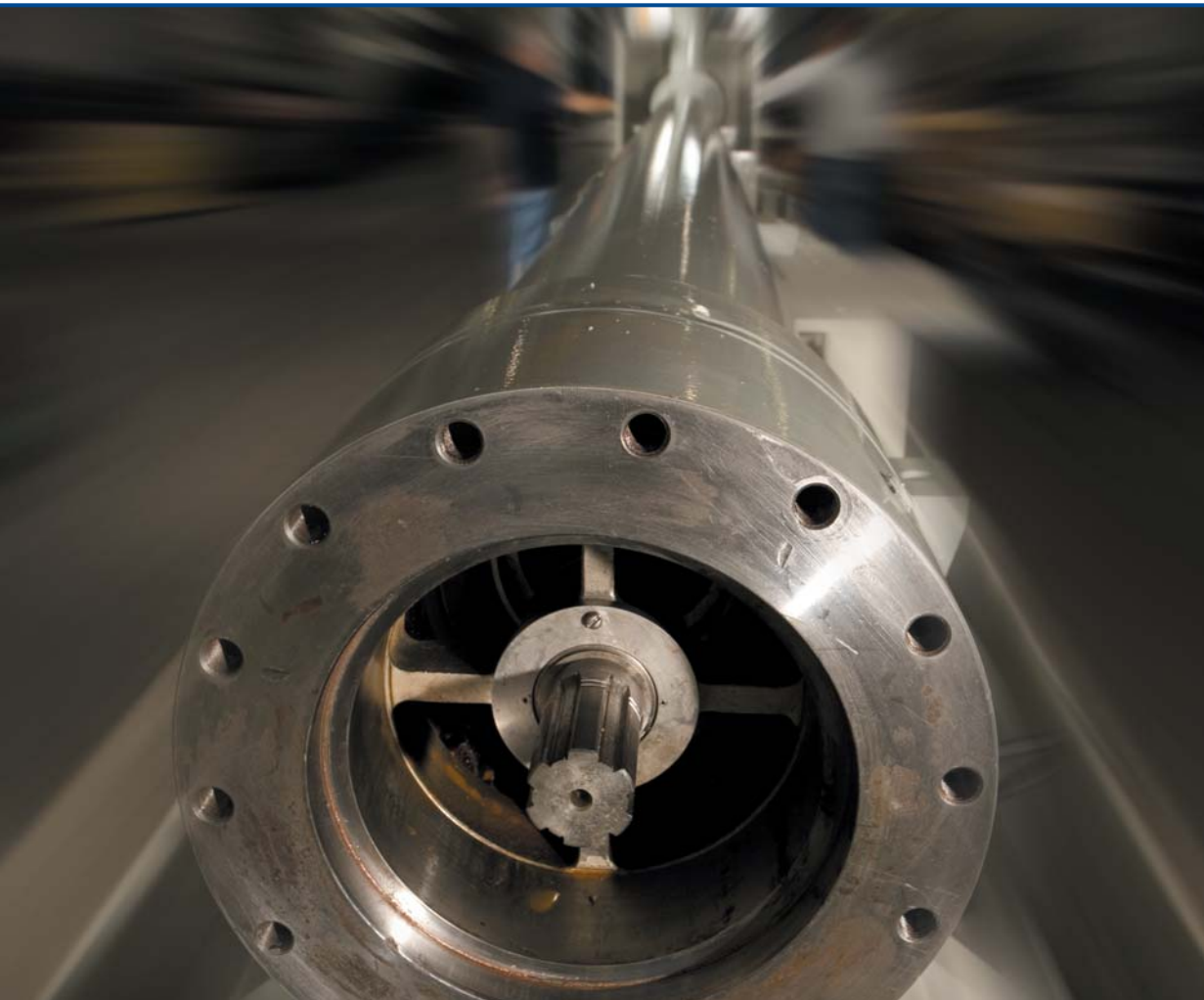

Reliable, powerful,
cost-effective

RedaHPS pumps continue to gain recognition, thanks to competitive capital costs, superior MTBF, and reduced maintenance expense.

Choose the dependable RedaHPS horizontal multistage pumping system for your next high-pressure pump application.

www.slb.com/redahps

Schlumberger

Table of Contents

1	Design	
1.1	Technical Design Data _____	1-1
1.2	Pump Performance Data _____	1-1
2	Equipment Information	
2.1	HPS Assembly Checklist _____	2-1
2.2	Motor Information _____	2-1
2.3	Seal Information _____	2-1
2.4	Pressure Switchgauge Information _____	2-1
2.5	Vibration Switchgauge Information _____	2-1
2.6	Motor/TC Coupling Information _____	2-1
2.7	Thrust Chamber Information _____	2-1
3	Drawings and Bills of Materials	
3.1	General Assembly Drawing and Bill of Materials _____	3-1
3.2	Thrust Chamber Serviceable Parts Drawing and Bill of Materials _____	3-1
3.3	Seal Drawing _____	3-1
3.4	Motor Drawing _____	3-1
3.5	Electrical Drawing _____	3-1
3.6	Pump Shaft Setting Procedure _____	3-1
3.7	Pump Drawing and Bill of Material _____	3-1
4	Pump Performance Tests and Reports	
4.1	Pump Test Results and Hydro Test Certs _____	4-1
4.2	Hydrostatic Test Certs (Intake and Discharge) _____	4-1
5	Recommended Spare Parts and Servicing Tools	
6	Installation and Commissioning	
6.1	Operational Checklist _____	6-1
6.2	Transport and Handling _____	6-3
6.3	Site Requirements _____	6-8
6.4	Piping Connections _____	6-10
6.5	Commissioning _____	6-12
6.6	Vibration _____	6-18
6.7	HPS Storage _____	6-23
7	Maintenance	
7.1	Lubrication Maintenance Summary _____	7-1
7.2	Recommended Maintenance Schedules _____	7-2
7.3	HPS Field Service Report _____	7-3
7.4	Decommissioning Procedures _____	7-7

Private

Copyright © 2008 Schlumberger, Unpublished Work. All rights reserved.

7.5	Recommissioning Procedures _____	7-9
8	Troubleshooting	
8.1	Troubleshooting Basics _____	8-1
8.2	Troubleshooting Electric Motors and Starters _____	8-2
8.3	Troubleshooting Thrust Chamber Vibrations _____	8-5
8.4	Troubleshooting Thrust Chamber Overheating (The HPS Unit Has a Thrust Chamber Cooling and Filtration System) _____	8-7
8.5	Troubleshooting Thrust Chamber Overheating (The HPS Unit Does Not Have a Thrust Chamber Cooling and Filtration System.) _____	8-8
8.6	Troubleshooting Instruments _____	8-10
8.7	Troubleshooting Gearbox Noise _____	8-11
8.8	Troubleshooting Gearbox Overheating _____	8-11
8.9	Troubleshooting Gearbox Vibration _____	8-11

List of Tables

7-1	Lubrication requirements for the motor, and thrust chamber _____	7-1
7-2	Lubrication chart for standard systems _____	7-1
7-3	Lubrication chart for flush-plan systems _____	7-2
7-4	Client and Date of Report _____	7-3
7-5	General Information _____	7-3
7-6	Pump Data _____	7-4
7-7	Motor Data _____	7-4
7-8	Engine-Driven Units _____	7-4
7-9	Thrust Chamber and Intake Assembly _____	7-5
7-10	Shutdown Switches _____	7-5
7-11	Observed Operating Parameters _____	7-5
7-12	Motor Maintenance Check List _____	7-6
7-13	Thrust Chamber Maintenance Checklist _____	7-6
7-14	Metastream Spacer Coupling Maintenance Checklist _____	7-6
7-15	General Operation Checklist _____	7-6
7-16	Vibration Measurements _____	7-7
8-1	Troubleshooting electric motors and starters _____	8-4
8-2	Troubleshooting Thrust Chamber Vibrations _____	8-6
8-3	Troubleshooting Thrust Chamber Overheating Problems on HPS Units With a Thrust Chamber Cooling and Filtration System _____	8-7
8-4	Troubleshooting Thrust Chamber Overheating Problems On HPS Units Without a Thrust Chamber Cooling and Filtration System. _____	8-9
8-5	Troubleshooting a Motor Starter That Does Not Engage _____	8-10

Intentionally Blank

Design

1.1	Technical Design Data	_____	1-1
1.2	Pump Performance Data	_____	1-1

Intentionally Blank

November 14, 2008

Tartan Engineering Ltd.
700,110 Twelfth Avenue S.W.
Calgary, Alberta
T2R 0G7

Attention: Muhammad Mairaj Ahmed

REDA^{*} HPS PUMPING SYSTEM PROPOSAL

Proposal Number: **1-JG1D16**

Client Reference: **RFQ 361700-001**

HPS Proposal for: **Husky Energy – Alliance Battery**

Service: **Disposal Pump Replacement**

Capacity: **4126 m3/d at 6895 kPa Discharge Pressure**

All the information contained in this document is the property of Schlumberger Canada Limited (SCL) and is to be treated as strictly confidential. Client or Purchaser is not allowed to disclose this information, in whole or in part, to any third parties without the prior written consent of SCL.

The following is a design proposal and equipment quotation for a Reda^{*} HPS centrifugal pump. The components selected are based on the process conditions and fluid properties stated on the Purchaser's centrifugal pump Data Sheet. If the Purchaser has not supplied a completed Data Sheet, SCL reserves the right to revise this proposal accordingly as more specific process conditions and fluid properties are made available.

Please note that as the Reda^{*} HPS Horizontal Pumping System is outside the scope of API and ANSI Centrifugal Pump Specifications, SCL takes full and complete exception to any and all references to said Specifications.

** Mark of Schlumberger*

Terms and Conditions

- Estimated delivery time for the pump and skid package is twenty four (24) weeks from receipt of order, subject to shop work load. Firm delivery will be determined upon Purchaser's approval of General Arrangement drawings.
- Standard payment terms are Net Thirty (30) Days.
- Prices are quoted in Canadian Dollars.
- This equipment quotation is valid for a period of ninety (90) days from the above date. Prices are not subject to escalation once a written order confirmation is received.
- Goods are quoted FCA (INCO Terms 2000) Nisku, Alberta with all transportation costs to be borne by the Purchaser.
- Each design, material specification, testing, or documentation change requested by Purchaser after approval of General Arrangement drawing will be subject to a \$2500 change fee, plus engineering time and materials costs.
- SCL takes exception to Purchaser's Summary of Requirements as indicated on the attached document.
- Purchaser agrees to accept delivery of the goods within thirty (30) days of notification of readiness to ship. Should Purchaser fail to accept delivery of the goods within the specified time, Purchaser agrees to pay a storage fee of two percent (2%) of the total invoice value, for each month or any portion thereof, that the goods are held by Schlumberger on behalf of the Purchaser.

Except for the matters specifically addressed in this document, this commercial proposal is subject to the set of Terms and Conditions attached as Schedule "A", and made a part hereof. In the absence of a Master Goods Agreement or Master Service Agreement between Purchaser and SCL, any work awarded to SCL as a result of this commercial proposal is to be governed by said terms and conditions.

Purchaser's Acceptance and Acknowledgement of Order

I, _____, as an authorized representative of Husky Energy, acknowledge the acceptance of the above terms and conditions, and authorize this order for the goods and services described in Schlumberger's Equipment Quotation 1-JG1D16,

(signature)

(date)

(title)

(AFE/Purchase Order Number)

Purchaser may accept this offer and order the equipment by agreeing to the above conditions and returning a signed copy of this document to Schlumberger.

If you have any questions regarding our proposal, please contact me at the number below.

Regards,

Derek Holden

HPS Sales Engineer – Reda* HPS Pumping Systems
Schlumberger Canada Limited
Telephone: 780-955-2800
Facsimile: 780-955-2921
Email: dholden@slb.com

Quote

Prepared for	TARTAN ENGINEERING LTD.	Country	Canada
Well		Field	Alliance
Tender reference #		Quote name	Tartan RFQ 361700-001 Husky Alliance
Quote #	1-JG1D16	Version #	1
Created Date	8/7/2008	Valid Up to	9/6/2008
Created by	Derek Holden	Approved by	Derek Holden

Sequence Number	Part Number	Alternate Description	Quantity	Line Item	External Comments
1	100444173	PUMP: M675-A C-CT 19 STG 862/862 19 CS BTHD, 1.37 INC 718, M-TRM, HSN, ARZ, SS H&B, HPS, BLUE PAINT	1		
2	100226149	MOTOR: SIEMENS, 700HP 460V 766A 60HZ, 5013SY, TEFC, SLEEVE BRG, BEARING/WINDING RTDS	1		Deviate as per Siemen Quote Q93354, include as well an oversized Junction Box 12" x 12" x 10" and a Vibration Transmitter.
3	139020350	WELDMENT ASSY, G3, ND, 3 CLAMP, 12.5 INCH HEIGHT, STD GRAY	1		
4	100163819	ASSEMBLY: COUPLING, METASTREAM, TSCS/TSKS 0230, W/7 IN SPACER, 2.375-2.625 BORE	1		
5	100013074	ASSEMBLY, GUARD, COUPLING, 17 IN, G2	1		
6	100447636	THRUST CHAMBER: ASSEMBLY, 1 BEARING, HPS, G3A, 1.18-6B SPLINE, STD BLUE	1		
7	7005564	SEAL: SHAFT, 1.500, HSN, M-TRM, TYPE 2, JC P/N C055-95, MATL CODE B97058M058M	1		
8	100538851	SEAL HOUSING: ASSY, G3, NON-CARTRIDGE, TYPE 2 SEAL, W/FLANGE O-RING	1		
9	3909512	ASSEMBLY: INTAKE, 8 IN, 150, RFWN, 316L SS, G2, MAWP-230 PSI	1		
10	3920299	JOINT:EXPANSION,W/RODS,8X6,240AV-NP-4,NITRILE TUBE,NEOPRENE COVER (FOR WATER & O	1		
11	3909572	ADAPTOR, END, INTAKE, 862/950 SERIES PUMP	1		
12	3907128	COUPLING: ASSY, 1.18-6B X 1.375-6B SPLINE, 3.52 IN., MONEL	1		
13	100330567	CLAMP: PUMP, HPS, 862 SERIES PUMP, STD GRAY	3		
14	3909102	HEAD ASSY: DISCHARGE, 6 IN., 900, RF, 862 SERIES, 316L SS, MAWP-1800 PSI	1		
15	3900501	SWITCH: MURPHY, VS2EX, VIBRATION TYPE, EXPLOSION PROOF	1		
16	100102422	CP: HPS-G3, 3 CLAMP, CLASS 600 INTAKE, COMPONENT HARDWARE DETAILS	1		
17	100155124	KIT, MOTOR MOUNTING,1.000 BOLTS	1		
18	100164429	KIT, HPS, O-RING SET, HSN, 862 SERIES	1		
19	100278072	KIT, DISCHARGE MOUNTING,862 SERIES PUMP,MONEL	1		
20	390DRAW	DRAWING, HPS UNIT, AS-BUILT	1		
					Quote Total :

The information in this proposal may not be disclosed outside of TARTAN ENGINEERING LTD. and may not be duplicated, used or disclosed in whole or in part for any purpose other than to evaluate the proposal. The estimated charges shown above may be exclusive of taxes. The final invoice will include all applicable taxes. Standard terms and conditions apply.

General Report

Schlumberger

Company:	Husky Energy / Tartan Engineering	Project:	HPS Design - Water Disposal Pump- Alliance Oil Battery 04-16-040-12w4m
Prepared By:	Derek Holden	Date:	8/7/2008

REDA HPS HORIZONTAL PUMPING SYSTEM

TECHNICAL DESIGN

Customer: Husky Energy / Tartan Engineering

Project: HPS Design - Water Disposal Pump- Alliance Oil Battery 04-16-040-12w4m

Flow: 4126.00 m³/d

Boost Pressure: 6965.51 kPa

Discharge Pressure: 1025.5 psig

Pump: M675-A 19 stages

Motor: SIEMENS, 700.0 hp, 460.0 Volts, 60.00 Hz

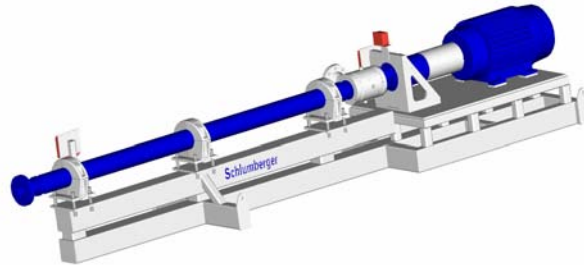

Date: 8/7/2008

General Report

Schlumberger

Company:	Husky Energy / Tartan Engineering	Project:	HPS Design - Water Disposal Pump- Alliance Oil Battery
Prepared By:	Derek Holden	Date:	04-16-040-12w4m 8/7/2008

Input Values

Process Input Data:		System Input Data:	
Liquid Type	Fresh water	Input Voltage:	
Specific Gravity	1.04	Area Classification:	Non Hazardous
Required Flow Rate:	4126.00 m3/d	Ambient Temperature:	29.00 °C
Required Suction Pressure:	15.3 psig	Liquid Temperature:	30.00 °C
Required Discharge Pressure:	985.31 psig	Input Frequency:	60 Hz
Required Boost Pressure:	970 psig	NOTES :	

Results Summary

Pump Summary:			
Operating Frequency	60.00 Hz	Pump Type	M675-A
Speed	3577.0 rpm	Stages	19
Power Required (@ Duty)	619.9 hp	Shaft Type	INCONEL 718
Run out Power	682.1 hp	Pressure Rating	2800 psig
Pump Efficiency	71.97 %	Shut in Pressure	1345.80 psig
Boost Generated	1010 psig	TDH	685.48 m

Component Details:			
Motor:		Thrust Chamber:	
Classification	Non Hazardous	Design Rating	5000.00 lbf
Voltage	460.0 Volts	Peak Downthrust	4540.58 lbf
Shaft Power	700.0 hp	Operating Downthrust	4540.58 lbf
Enclosure	TEFC	NOTES :	
Frame	5013S		
Bearing Type	BALL		
NOTES :			
Seal:		Skid Type:	
Seal Type	TYPE 2	Model	ND
Cartridge Seal	NC	Overall Unit Length	7.6 m
Seal Flush Type	Plan 2	NOTES :	
NOTES :			
Intake Flange:		Discharge Flange:	
Size:	203.19 mm	Size:	152.39 mm
Flange Class	150	Flange Class	900
Configuration:	RF	Configuration:	RF
Material:	316L SS	Material:	SS

General Report



Company:	Husky Energy / Tartan Engineering	Project:	HPS Design - Water Disposal Pump- Alliance Oil Battery
Prepared By:	Derek Holden	Date:	04-16-040-12w4m 8/7/2008

Limits

Process Input Data:			
Frequency	60.00 Hz	Controller kW	543.13
Voltage	460.0 Volts	Controller kVA	609.58
Motor Amps	766.0 Amps	PF at Controller	0.89
Motor Rating	700.0 hp		
Pump Power Draw	619.9 hp		
Motor Load Factor	88.55 %		

System Summary at Design Point:		System Summary at Maximum Condition:	
Pump:		Pump:	
MAWP Rating	2800 psig	MAWP Rating	2800 psig
Discharge Pressure	1025.5 psig	Discharge Pressure	1345.80 psig
Pressure Load Factor	23.30 %	Pressure Load Factor	30.58 %
Shaft Rating	1569.7 hp	Shaft Rating	1569.7 hp
Required Power	619.9 hp	Peak Required Power	682.1 hp
Shaft Load Factor	39.49 %	Shaft Load Factor	43.45 %
Thrust Chamber:		Thrust Chamber:	
TC Rating	5000.00 lbf	TC Rating	5000.00 lbf
TC Load Factor	90.81 %	TC Load Factor	90.81 %
Flanges:		Flanges:	
Intake Rating	230.0 psig	Intake Rating	230.0 psig
Load Factor	6.65 %	Load Factor	6.65 %
Discharge Rating	1800.0 psig	Discharge Rating	1800.0 psig
Discharge Load Factor	56.97 %	Discharge Load Factor	74.76 %

General Report



Company:

Husky Energy / Tartan Engineering

Project:

HPS Design - Water Disposal Pump- Alliance Oil Battery
04-16-040-12w4m
8/7/2008

Prepared By:

Derek Holden

Date:

8/7/2008

Husky Energy / Tartan Engineering HPS Design - Water Disposal Pump- Alliance Oil Battery 04-16-040-12w4m M675-A

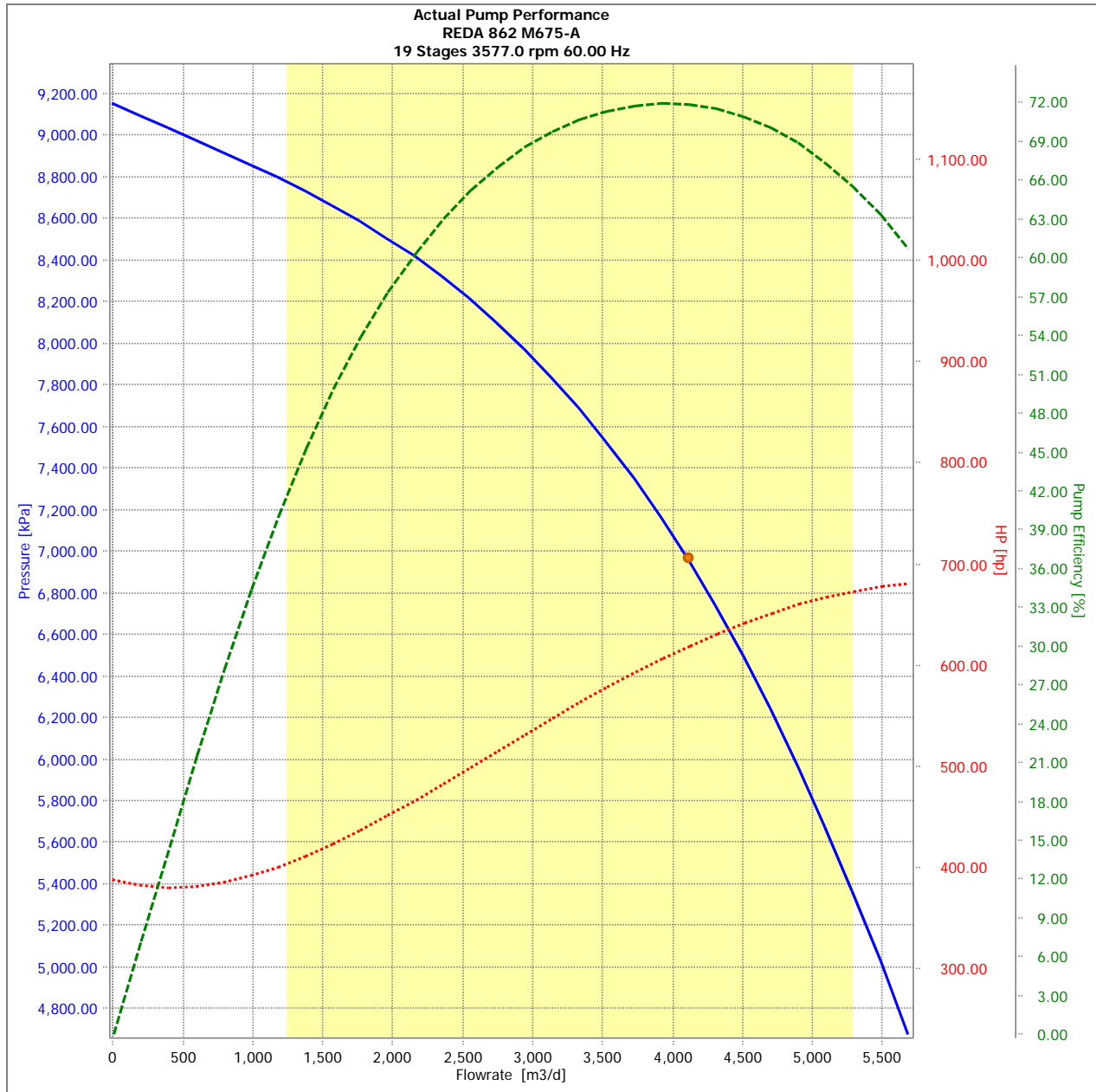

General Report



Company:	Husky Energy / Tartan Engineering	Project:	HPS Design - Water Disposal Pump- Alliance Oil Battery 04-16-040-12w4m
Prepared By:	Derek Holden	Date:	8/7/2008

Appendix

Husky Energy / Tartan Engineering HPS Design - Water Disposal Pump- Alliance Oil Battery 04-16-040-12w4m M675-A NPSH Actual Curves Plot

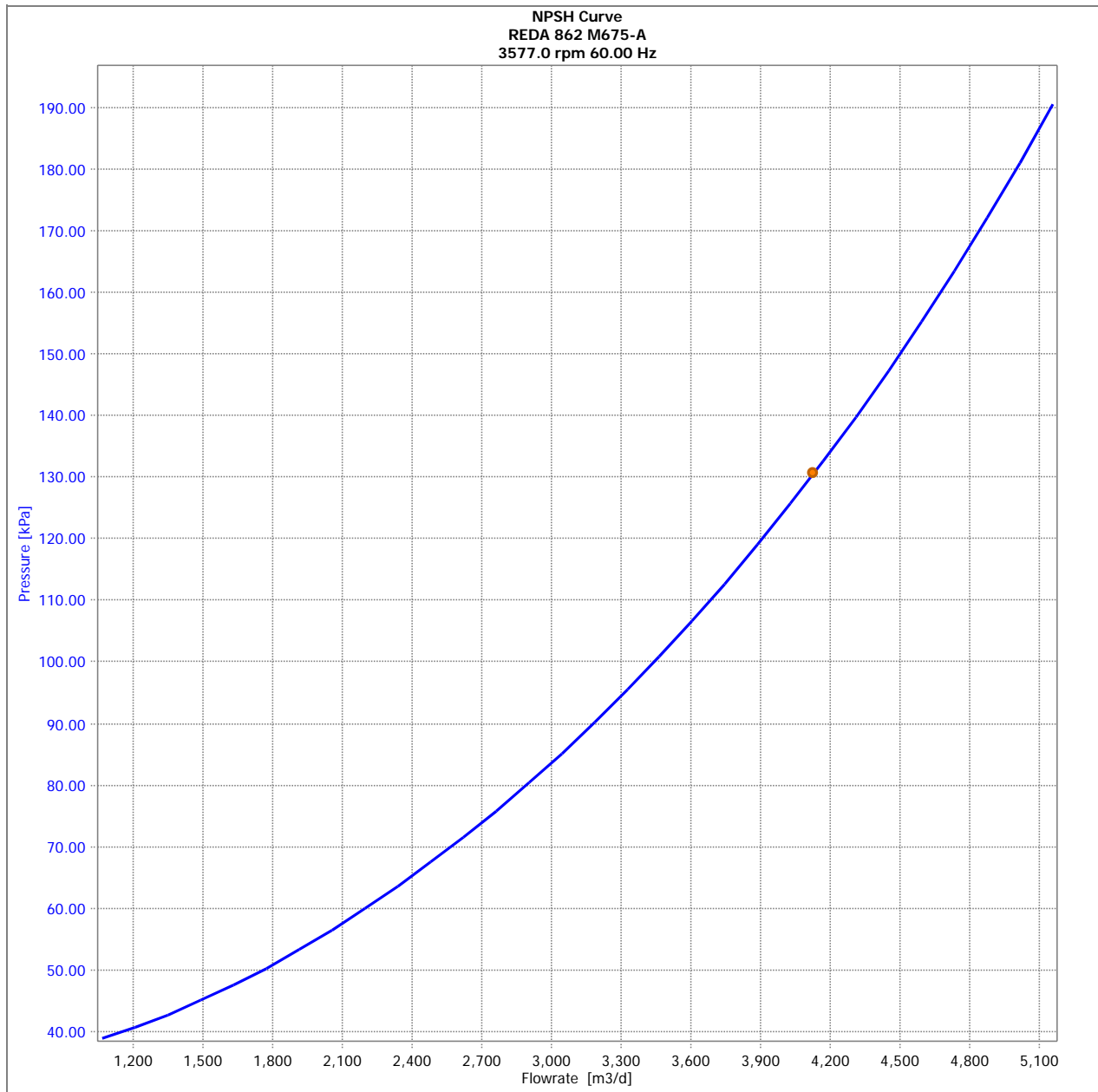

General Report



Company:

Husky Energy / Tartan Engineering

Project:

HPS Design - Water Disposal Pump- Alliance Oil Battery
04-16-040-12w4m

Prepared By:

Derek Holden

Date:

8/7/2008

Husky Energy / Tartan Engineering HPS Design - Water Disposal Pump- Alliance Oil Battery 04-16-040-12w4m M675-A VSD Curves Plot

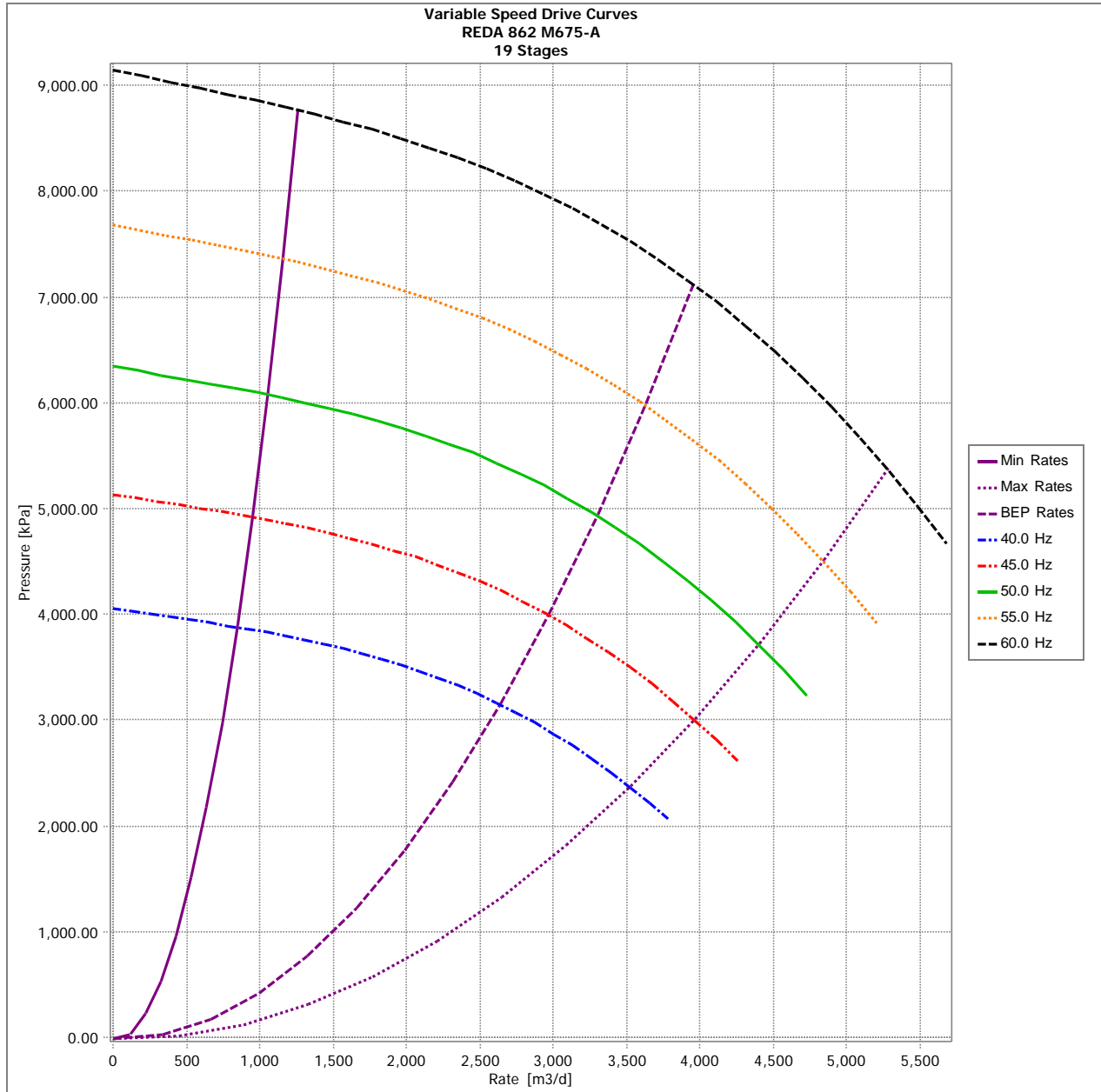

General Report



Company:

Husky Energy / Tartan Engineering

Project:

HPS Design - Water Disposal Pump- Alliance Oil Battery
04-16-040-12w4m
8/7/2008

Prepared By:

Derek Holden

Date:

8/7/2008

Skid Diagram

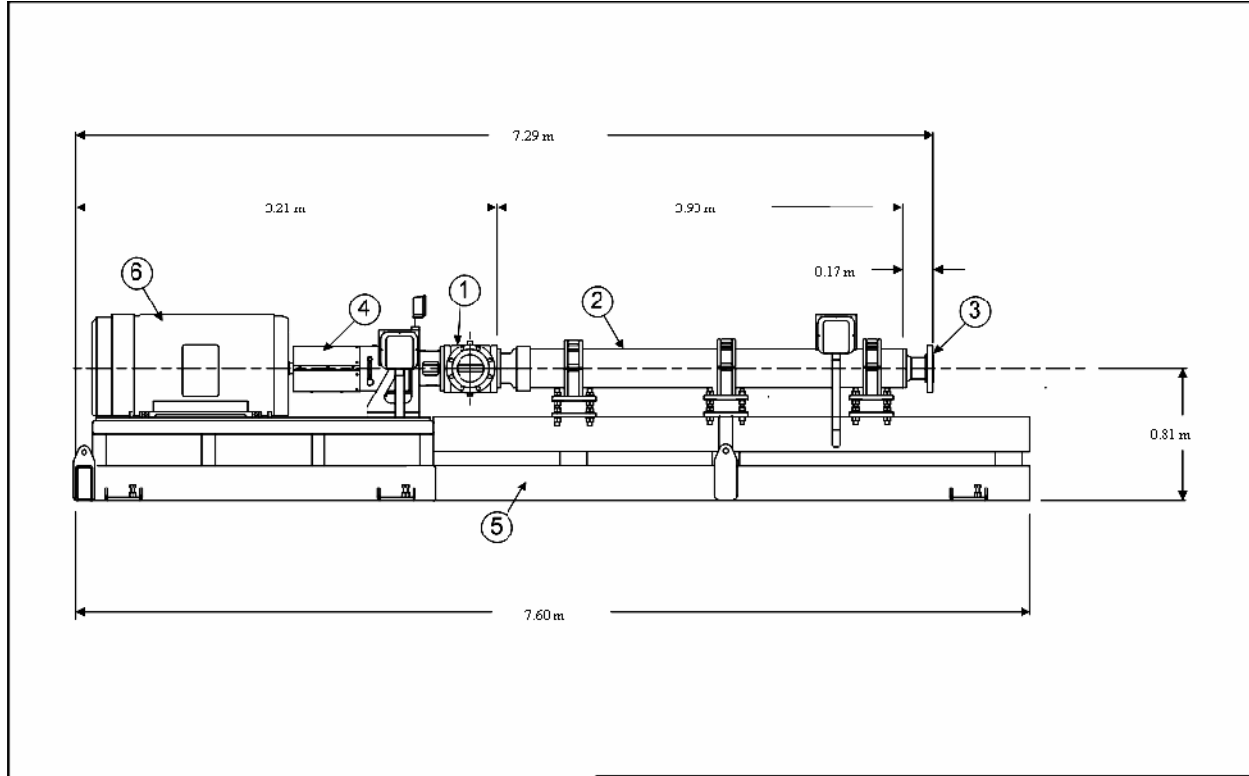

Parts List				For quotation purposes only, this drawing contains estimated dimensions and weights. Drawing not to scale. DO NOT CERTIFY	Confidential and trade secret. Do not disclose or reproduce without prior written approval from Manufacturer	Husky Energy / Tartan Engineering			
Item	Description					Design Data			
1	Intake Flange:	203.19 mm	ANSI 150			Designed By:	Derek Holden	Length:	7.29 m
2	Pump:	19 Stage	M675-A			Approved By:		Width:	1.13 m
3	Discharge Flange:	152.39 mm	ANSI 900			Date:	8/7/2008	Weight:	3.00 lbs
4	Thruet Cambor:	1 Deazing	5000.00 lbs						
5	Skid Assembly:	ND	3 Clamps						
6	Motor:	700.0 hp	TEFC 460.0 Volts						
				© Schlumberger 2006	Reda-HPS				

Equipment Information

2.1	HPS Assembly Checklist _____	2-1
2.2	Motor Information _____	2-1
2.3	Seal Information _____	2-1
2.4	Pressure Switchgauge Information _____	2-1
2.5	Vibration/ Switchgauge Information _____	2-1
2.6	Motor/TC Coupling Information _____	2-1
2.7	Thrust Chamber Information _____	2-1

Intentionally Blank

2-1

HPS Assembly Checklist

CUSTOMER Husky
LOCATION _____
FIELD Alliance

TICKET NUMBER 25645
DATE July 8, 2009
SERVICE TECH Coely J. Turner

SKID: MODEL Gen 3 S.N. 0137-CA9 P/N _____

EQUIPMENT CHANGED OUT

~~MOTOR: HP _____ VOLTS _____ AMPS _____ MANUFACTURER _____
PUMP: TYPE _____ S/N _____ HSG _____ P/N _____ STGS _____ THRUST _____
PUMP: TYPE _____ S/N _____ HSG _____ P/N _____ STGS _____ THRUST _____
THRUST CHAMBER: MODEL NUMBER _____ S/N _____ P/N _____
COMMENTS: _____~~

EQUIPMENT INSTALLED

MOTOR: MANUFACTURER Siemens S/N 2070538-010-1 HP 700 AMPS 719 VOLTS 480
S.F. 1.15 FRAME 5812SY ENCL TEFC RPM 3575

THRUST CHAMBER: MODEL NUMBER Gen3A-1B S/N XDBSK10963 P/N 100447636

INTAKE JACKET: MATERIAL SS STD yes HIGH PRES No RATING 150 Ansi

INTAKE: PIPED IN SOLID No EXPANSION JOINT USED yes SIZE 8" Drilled Neoprene skid

PUMP: TYPE M675A S/N 2SE9A5284 HSG 19 P/N 10044413 STGS 19 THRUST C-CT-AR

TRIM: HEAD CS BASE SS HSG CS
PUMP: TYPE _____ S/N _____ HSG _____ P/N _____ STGS _____ THRUST _____
TRIM: HEAD _____ BASE _____ HSG _____

DISCHARGE SIZE 6" RATING 900 Ansi MATERIAL SS P/N 3909102

PRESSURE SWITCH: MANUFACTURER Vibration Switch
INTAKE SETTING LOW _____ INTAKE SETTING HIGH _____
DISCHARGE SETTING LOW _____ DISCHARGE SETTING HIGH _____

MOTOR CONTROLLER: MANUFACTURER _____ MODEL NUMBER _____
VOLTAGE _____ AMPERAGE _____

STARTUP INFORMATION



SUPPLY PRESSURE _____ DISCHARGE PRESSURE _____ SPGR _____
AMPERAGE _____ PRODUCTION RATE _____
FLUID TEMP _____ PUMP TEMP _____ MOTOR TEMP: DRIVE END _____ NON-DRIVE END _____
THRUST CHAMBER TEMP: MOTOR _____ MIDDLE _____ PUMP _____

Intake -> Part Number #3909512
Serial Number # JPB8L21464

Discharge flange -> Part # 09102
SN # JDB8157459

8" expansion joint and control rods strapped to skid.

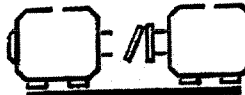
DISCOVER _____ PHONE _____
PHONE _____

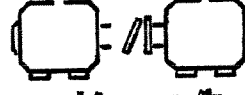
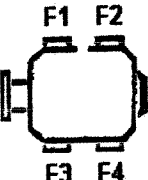
Serial Number - <u>0137-CA9</u>		Skid Model <u>G3</u>		
Customer <u>Husky - Alliance</u>				
Verified motor to BOM and Blueprint: <u>Jim</u>				
HP <u>700</u>	Volts <u>480</u>	Amps <u>719</u>	Serial # <u>2070538-010-1</u>	
Motor Alignment:				
Vertical Offset  (+) \uparrow (-) \downarrow <u>-.0004"</u>	Vertical Gap  (+) \uparrow (-) \downarrow <u>-.0003"</u>	Horizontal Offset  (+) \rightarrow (-) \leftarrow <u>.0001"</u>	Horizontal Gap  (+) \rightarrow (-) \leftarrow <u>.0002"</u>	
Motor Soft Foot  F1 F2 F3 F4	<u>.0002"</u> F1	<u>.0002"</u> F2	<u>.0006"</u> F3	<u>.0002"</u> F4
Sleeve Bearing <input checked="" type="checkbox"/> Yes <input type="checkbox"/> No		Measurement Mag Center		
Alignment by: <u>Shawn R</u>				
Coupling Size and Type used: <u>merdestream 230</u> PN# <u>100163819.</u>				
Installed and Greased (if applicable) by: <u>NA</u>				
Thrust Chamber:				
Thrust Chamber Serial Number: <u>XDBSK10963</u> <u>codey</u>				
Thrust Chamber Model Number: <u>Gen3 A-1B</u> <u>codey</u>				
Thrust Chamber Type Verified and Installed by: <u>codey</u>				
Coupling Guard installed by: <u>Sent with junction box</u>				
Verified Oil in Thrust Chamber by: <u>codey</u> <u>yes</u>				
Pump Seal Verified by: <u>codey</u>				
Pump Seal Installed by: <u>codey</u>				
Intake verified and installed by: <u>codey</u>				
Cleats attached to intake (if required) by: <u>N/A.</u>				

Cooler Package:			
Serial Number:			
Correct Oil installed Verified by:			
Electrical Wiring Verified by:			
Oil & Fan correct rotation Verified by:			
Flow Control Valve installed by:			
Pump Alignment:			PUMP #1
Gap - <i>No Gap</i>	Height <i>3/64" low</i>	Side to Side <i>1/32" off opposite intake to left</i>	
Pump shimmed to:	Float	1/16 <i>.060"</i>	1/32
Thickness of shims used: <i>.195" split shims on comping</i>			
Serial Number <i>295E9A-52840</i>		Stages <i>9</i>	
Pump O-ring, Discharge O-ring verified and installed by: <i>Cody Turner</i>			
Pump Alignment:			Pump #2
Gap - <i>No Gap</i>	Height	Side to Side	
Down Thrust	Up Thrust	Total	
Pump shimmed to:	Float	1/16	1/32
Thickness of shims used:			
Serial Number		Stages	
Pump O-ring, Discharge O-ring verified and installed by:			
Flush Plan:			
Tubing installed by:		Fittings installed by:	
Type of Plan:			
Block and Bleed valve installed by:			
Barrier Bottle (if required) <input type="checkbox"/> Yes <input type="checkbox"/> No			
Lemco Bottle verified and installed by:			
Fittings Installed by:			
Proper Drain Orientation <input type="checkbox"/> Yes <input type="checkbox"/> No		Verified by:	
Barrier Fluid filled by:			No Leaks

Electrical:
Switches verified and installed by: <i>Cody . vibration and brackets .</i>
Wiring Installed by: <i>N/A</i>
Vibration Switches set by: <i>N/A</i>
Final Inspection by QA:
Jack pad bolts installed with locknuts by: <i>Cody .</i>
Verified all nuts and bolts for tightness by: <i>Cody + Shaun</i>
Verified all Flange Covers in place by: <i>Cody .</i>
Verified Name Plates and Sticker Information by: <i>Cody .</i>
Ready to Ship: <i>July 13/09</i> <input checked="" type="checkbox"/> <i>YES</i> Date:
Comments (if any) on:
Motor Alignment: <i>Motor coupling sent with skid. Block</i>
Thrust Chamber: <i>attached to motor for shipping</i>
Cooler package:
Pump Alignment:
Flush plan:
Electrical:

Company: *Husky / Alliance*.....

Left Machine
Thrust chamber

Coupling
Metrotren 830

Right Machine
Motor

VERTICAL RESULTS

- Inch

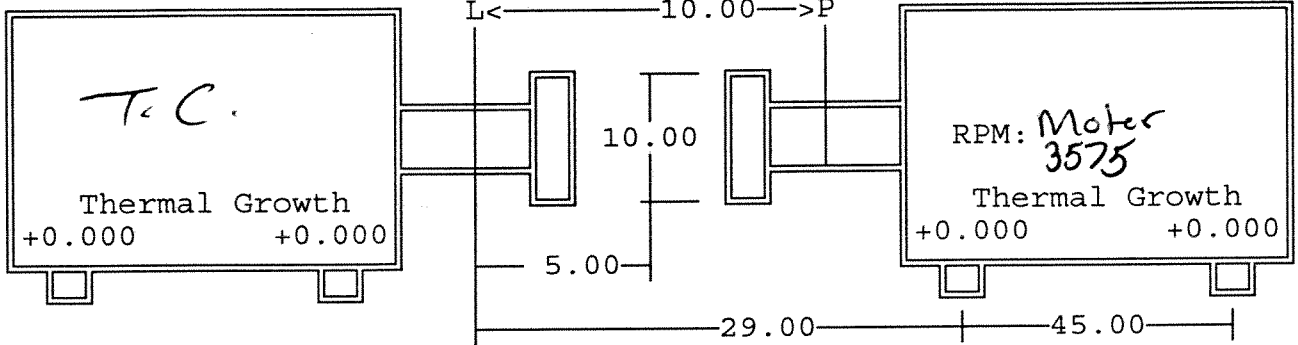

	Gap	Offset	Corrections	
Target	/+0.0000	L+0.0000	-0.000	-0.002
Actual	\ -0.0003	r -0.0004	--	--

HORIZONTAL RESULTS

- Inch

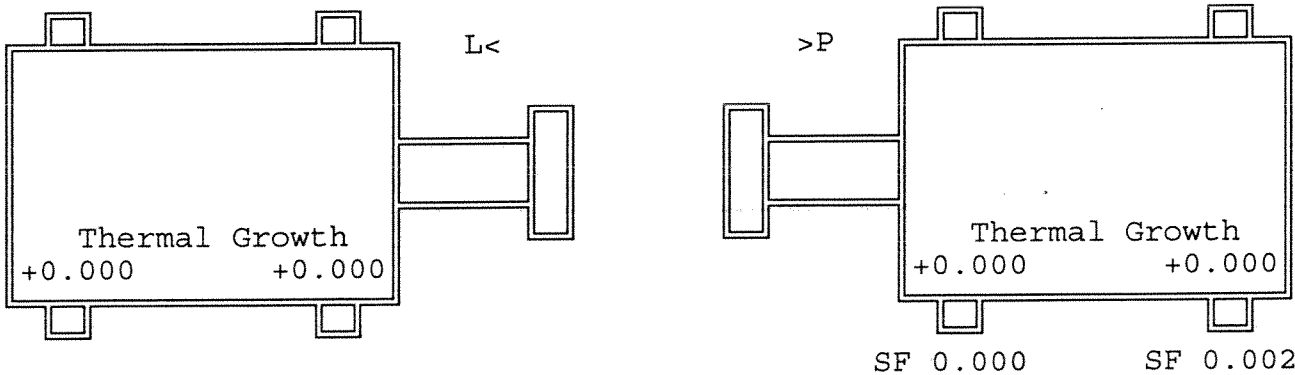

	Gap	Offset	Corrections	
Target	/+0.0000	L+0.0000	+0.000	+0.001
Actual	/+0.0002	r-0.0001	--	--

Operator: *CT*.....

2009 07.16 08:10A

Page:1

skid sn# 0130-CA9

2-2

Motor Information

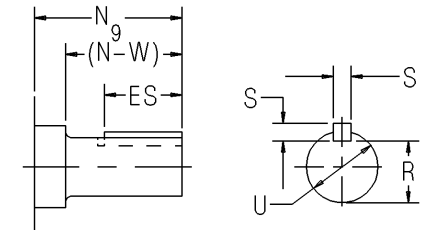
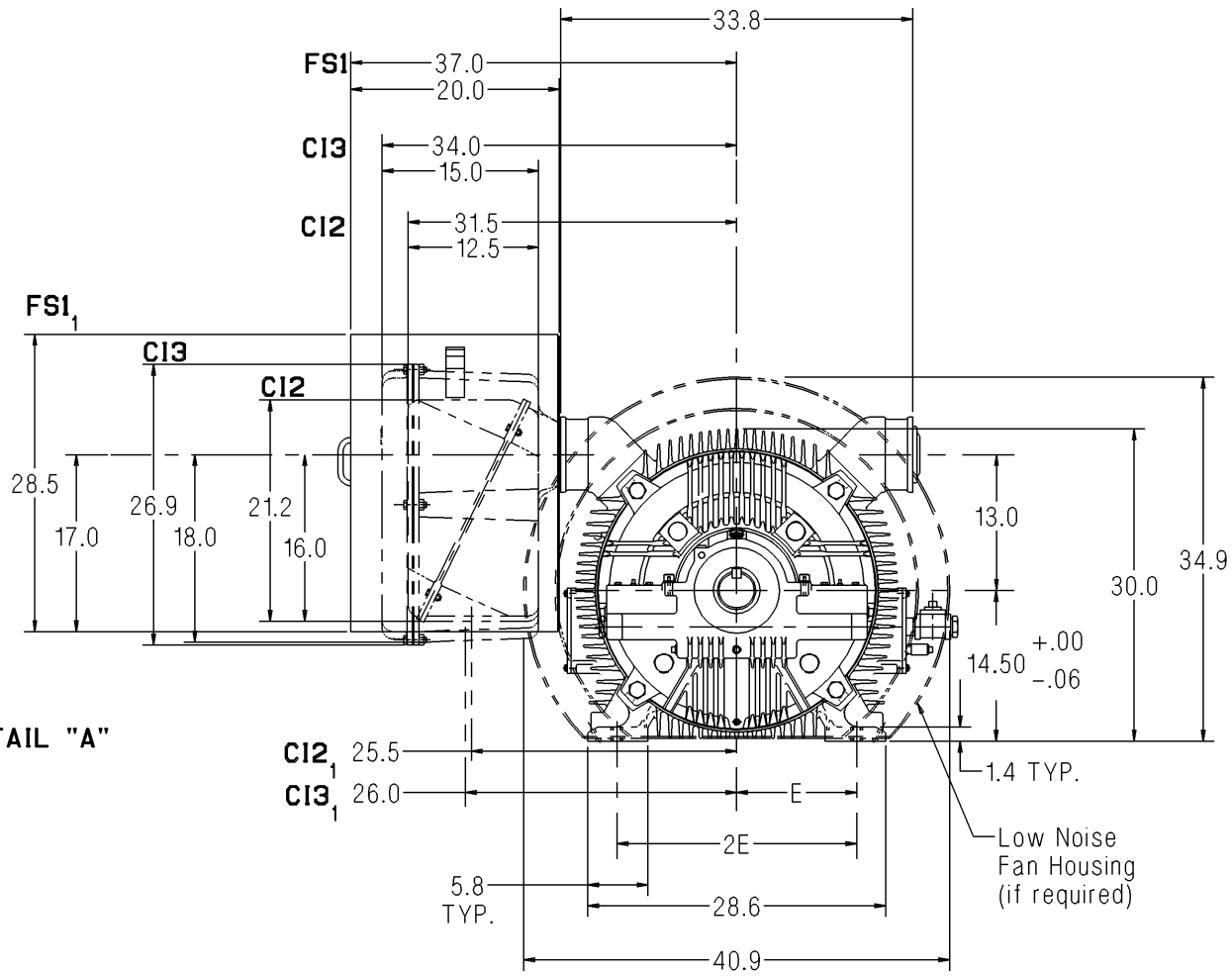
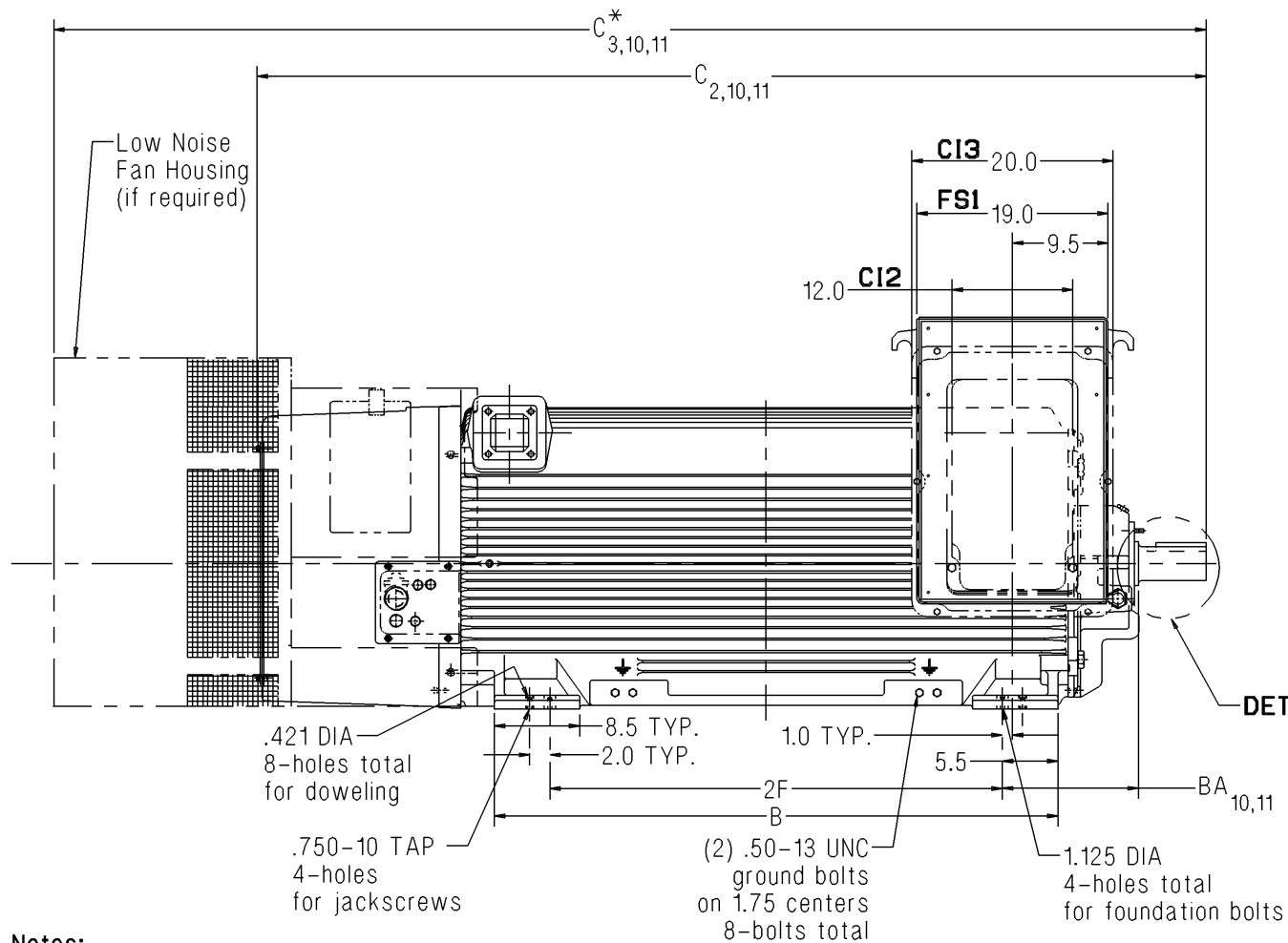

Notes:

- Main conduit box may be rotated in steps of 90°. A removable bottom plate is supplied on the FS1 conduit box. A 5.0 N.P.T. is supplied on the C12 and C13 conduit boxes.
- C = Length of motor from drive end of shaft to end of standard fan housing.
- C* = Length of motor from drive end of shaft to end of low noise fan housing.
- V = (N-W)-0.25" = length of shaft available for coupling.
- 2 Pole machines may rotate in one direction only.
- Shims may be necessary under motor feet for direct connection.
- Rotor end float = 0.5"
- End float of LEF coupling = 0.19"
- A rotating labyrinth seal is mandatory on the 5812 frame for 2 pole machines. Adding a rotating labyrinth seal to the drive end decreases N by:
2 Pole: see table for N dimension 4 Pole & Slower: 0.36"
- When adding a ground brush, consult the factory. (BA, C, and C* will increase.)
- An external keyphasor, if requested, mounts on the drive end. An external keyphasor (with or without rotating labyrinth seal) increases BA, C, and C* by:
2 Pole: 2.00" 4 Pole & Slower: 2.00"
- Flood lube piping is mandatory on the 5812 frame for 2 pole machines.
- Use this print for motors equipped with provisions for proximity probes for our standard internal mounting.

Lubrication Per Bearing	
2 Pole	4 Pole & Slower
140-160 SUS @ 100°F	290-350 SUS @ 100°F
2.6 qt. capacity	2.6 qt. capacity

Standard Dimensions in Inches

Shaft	Frame	Speed	B	BA _{10,11}	C _{2,10,11}	C* _{3,10,11}	E	2F	N ₉	(N-W)	R	S	U	V ₄	ES	Approx. Ship Wt. (Lbs)
Short	5812SY	2 Pole	56.0	13.50	94.3	114.6	11.50	45.0	6.79	6.75	2.880	0.875	3.375	6.50	5.0	8500
Short	5812SY	4 Pole & Slower	56.0	13.50	95.3	115.6	11.50	45.0	8.00	7.75	3.309	1.000	3.875	7.50	6.0	8900

Certification: Customer _____ P.O. _____ S.O. _____ Item _____
 HP _____ RPM _____ Frame _____ PH/HZ/Volts 3/_____/_____
 By _____ Date _____ Terminal Box Size C12 C13 FS1

Comments _____
 Not for construction, installation or application purposes unless certified.

INDUCTION MOTOR DATA
Siemens Energy & Automation, Inc
Norwood, Ohio

Customer : HESCO
 Schlumberger

Application : Centrifugal Pump
 Proposal Number : 93354-02

SPECIFIED REQUIREMENTS

Horsepower : 700
 Service Factor : 1.15
 Voltage : 480
 Number of Phases : 3
 Frequency, hertz : 60
 Ambient, deg C : 40
 Enclosure : TEFC
 Synchronous Speed, RPM : 3600
 Percent Starting Voltage : 90

FRAME DATA

Frame : 5812
 Type : CZ
 Rotor Construction : Fabricated Copper Bar
 Type Bearings : Sleeve, flood lube required
 Rotor Inertia (wk2), lb-ft2 : 202
 Rotor Weight, lbs : 1357 (Approximate)
 Motor Weight, lbs : 8000 (Approximate)
 Degree of Protection : IP54
 Method of Cooling : IC411

PERFORMANCE DATA

Full Load Speed, RPM :	3575	Full Load Torque, lb-ft :	1028
Current, Amps :	716	Starting Torque, %FLT :	60
Locked Rotor Current, % FLA :	585	Breakdown Torque, %FLT :	220
KVA/Hp :	4.98		
Code :	E		

	<u>0.25</u>	<u>0.50</u>	<u>0.75</u>	<u>Full</u>	<u>1.15</u>	<u>No</u>	<u>Locked</u>
	<u>Load</u>	<u>Load</u>	<u>Load</u>	<u>Load</u>	<u>Load</u>	<u>Load</u>	<u>Rotor</u>
Percent Efficiency :	90.7	94.3	95.0	95.1	95.0	-----	-----
Percent Power Factor :	82.3	80.9	92.4	92.2	91.6	13.6	13.8
Current, Amps :	210.3	411.5	536.4	716.1	829.7	102.0	4189

	<u>100 % Voltage</u>	<u>90 % Voltage</u>
Safe Stalled Time, Motor Hot :	24.5 Seconds	32.9 Seconds
Safe Stalled Time, Motor Cold:	30.1 Seconds	38.1 Seconds
Acceleration Time :	16.8 Seconds	27.3 Seconds
Starting Load :	Assumed load inertia and startup torque per NEMA	
Load wk2:	503 lb-ft sq (assumed)	

Time Constants :	2.661 Seconds Open Circuit
	0.0648 Seconds Short Circuit (AC)
	0.0594 Seconds Short Circuit (DC)
X/R Ratio :	22.38

Note : Afc operation requires blocking out speed range near critical speed. Filtered drive.

Computer File Reference : Automate

Prepared by : JSP

Date : 1-Dec-08



HESCO
Schlumberger
Q-93354-02

Siemens Energy & Automation, Inc
Power Conversion Division
Norwood, Ohio

SPEED vs TORQUE & CURRENT at 60 HERTZ

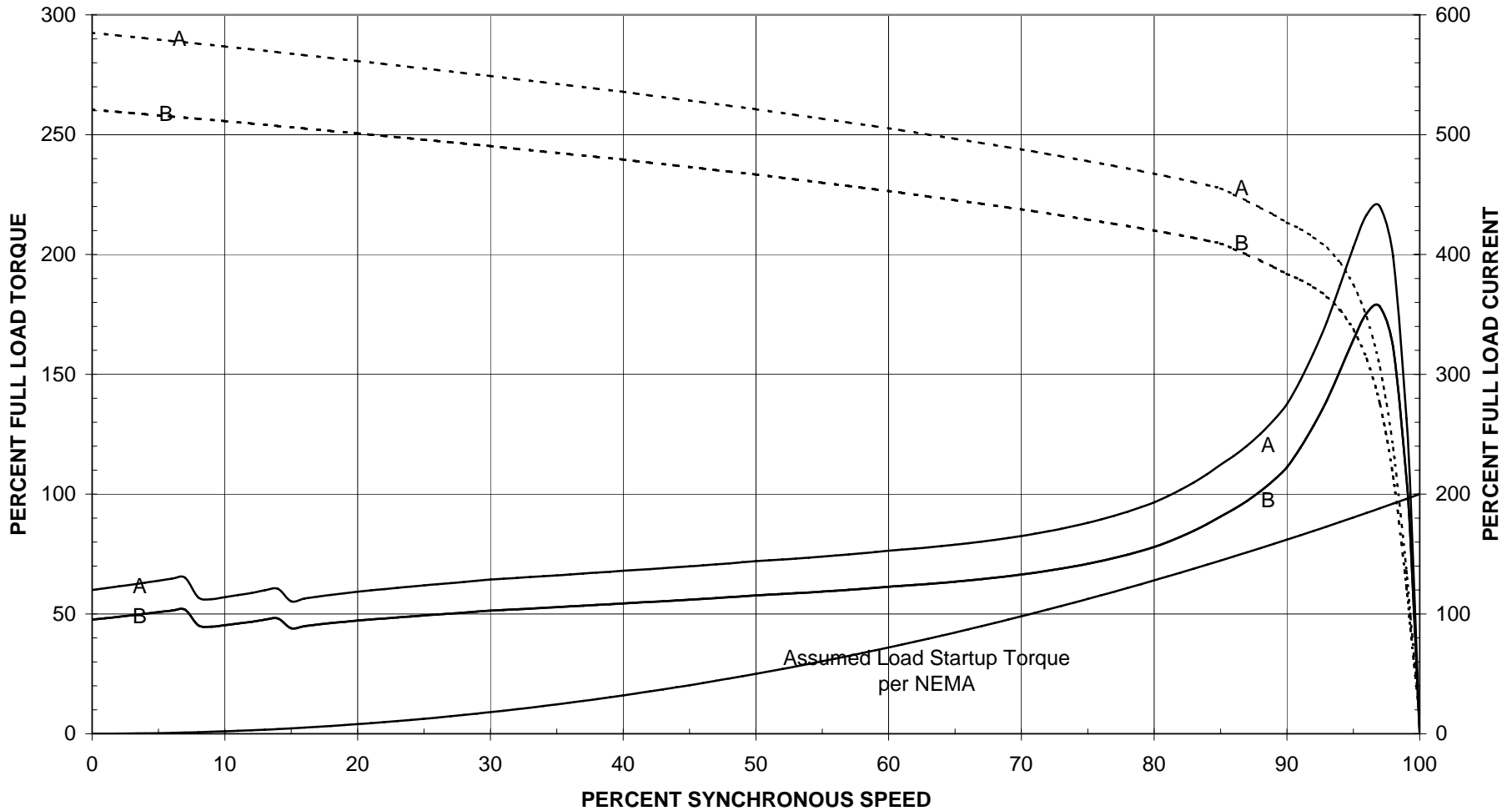

700 HP 480 Volts
60 HZ 3575 RPM
716 Amps 1.15 SF
5812 Frame Type CZ

Solid Lines = Torque; Dashed Lines = Current
A = 100 Percent Voltage
B = 90 Percent Voltage



HESCO
Schlumberger
Q-93354-02

Siemens Energy & Automation, Inc
Power Conversion Division
Norwood, Ohio

Time vs Current at 60 Hertz

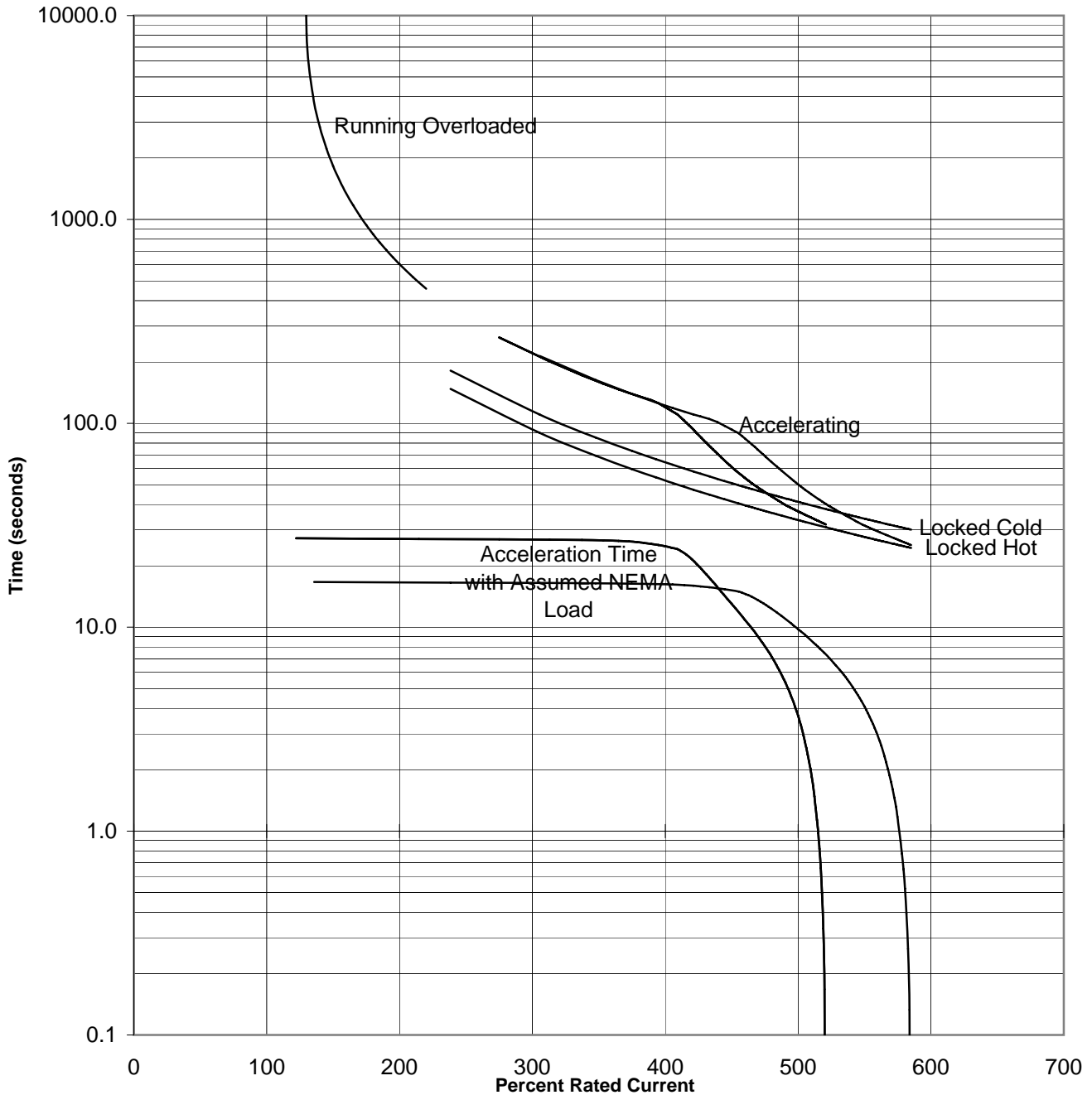

700 HP 480 Volts
60 HZ 3575 RPM
716 Amps 1.15 SF
5812 Frame Type CZ

Thermal Limit
100 Percent Voltage
90 Percent Voltage

12/01/08

2-3

Seal Information



TYPE 2/2B

Elastomer Bellows Seals

2/2B

- A – Face/Primary Ring
- B – Spring
- C – Elastomer Bellows
- D – Retainer
- E – Drive Band
- F – Spring Holder
- G – Disc

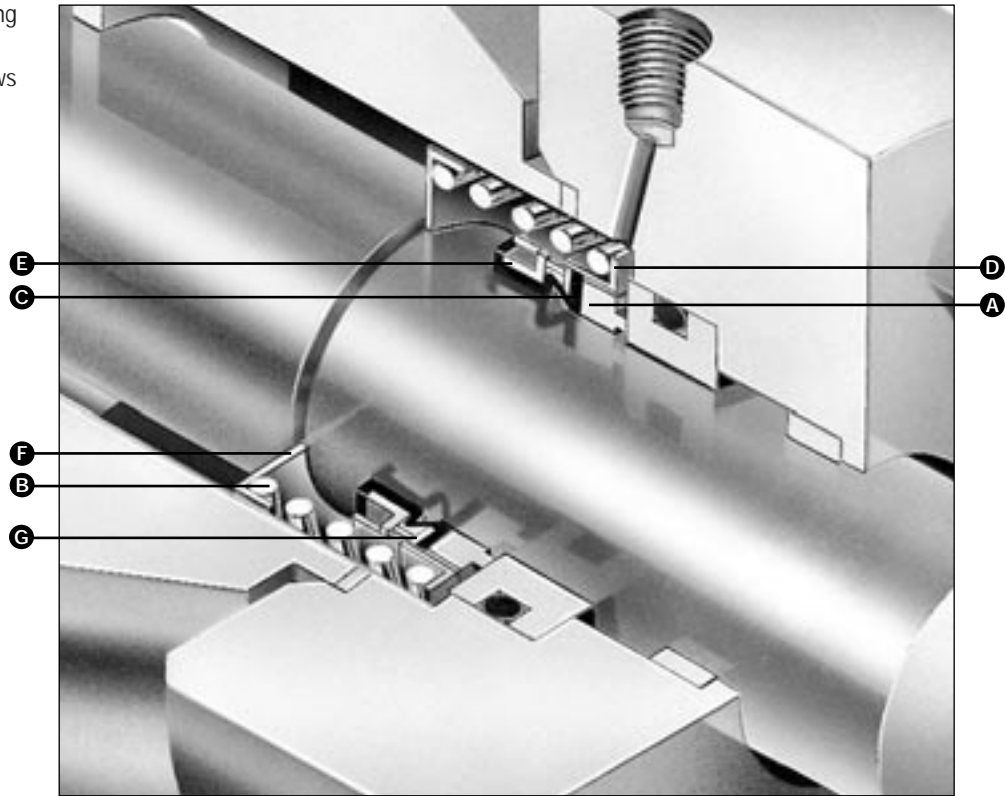

Product Description

John Crane Type 2 Elastomer Bellows Seals are specified in more original equipment than any other seal from any other manufacturer. With the highest success rate of any seal of their type, they are suitable for a wide range of service conditions, including water, refrigeration, oils and chemicals.

- Fits equipment with confined space requirements and limited seal chamber depths in pumps, mixers, blenders, agitators, compressors and other rotary shaft equipment.
- For pulp and paper, food processing, water, wastewater, refrigeration, chemical processing and other demanding applications.
- Type 2B is a balanced seal used in higher pressure applications, offering greater operating speeds and reduced face wear.

Performance Capabilities

- Temperature:
-40°C to 205°C/-40°F to 400°F
(depending on materials used)
- Pressure:
2: Up to 29 bar g/425 psig
2B: Up to 83 bar g/1200 psig
- Speed:
See enclosed Speed Limits chart.

Design Features

- Mechanical Drive — Eliminates overstressing of the elastomer bellows.
- Self-Aligning Capability — Automatic adjustment compensates for abnormal shaft end play runout, primary ring wear and equipment tolerances.
- Special Balancing — Allows operation at higher pressures.
- Non-Clogging, Single-Coil Spring — Not affected by buildup of solids.



TYPE 2/2B

Elastomer Bellows Seals

Type 2 Typical Arrangement/Dimensional Data

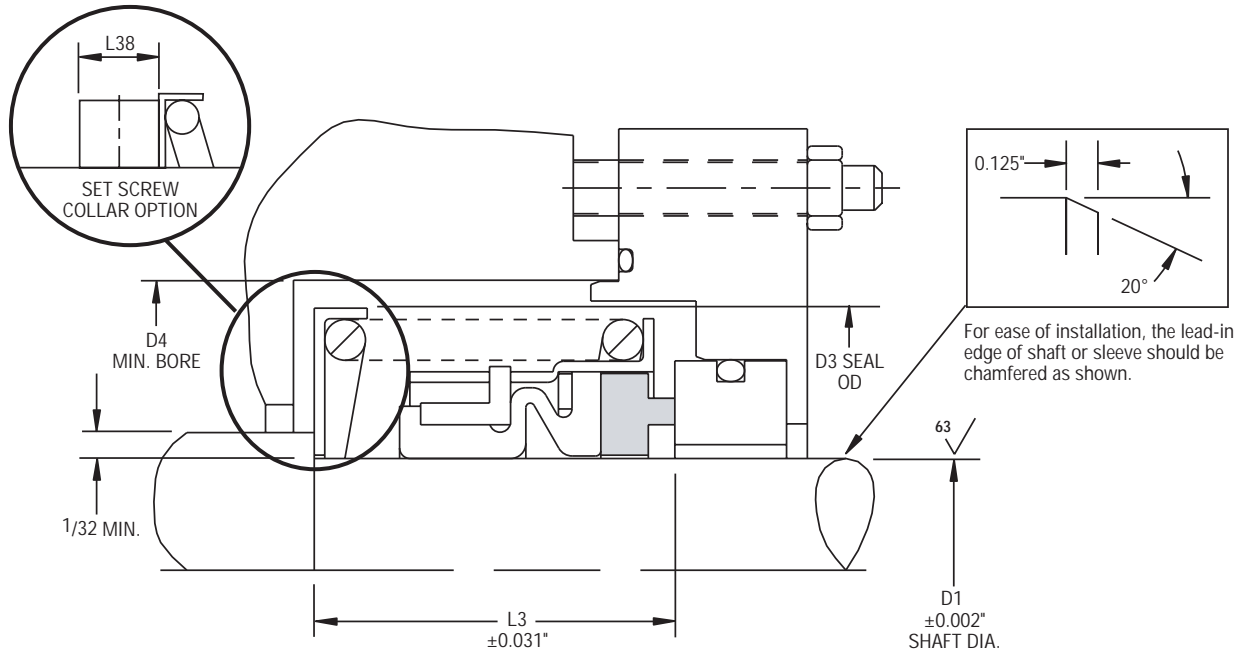

Type 2 Dimensional Data (inches)

Seal Size/D1 (inches)	D3	D4	L3	L38
1.000	1.812	2.000	1.000	0.375
1.125	1.937	2.125	1.062	0.375
1.250	2.062	2.250	1.062	0.375
1.375	2.250	2.437	1.125	0.375
1.500	2.375	2.562	1.125	0.375
1.625	2.718	2.937	1.375	0.375
1.750	2.750	3.062	1.375	0.375
1.875	2.875	3.187	1.500	0.375
2.000	3.000	3.312	1.500	0.375
2.125	3.250	3.625	1.687	0.500
2.250	3.375	3.750	1.687	0.500
2.375	3.500	3.875	1.812	0.500
2.500	3.625	4.000	1.812	0.500
2.625	3.875	4.312	1.937	0.500
2.750	4.000	4.437	1.937	0.500
2.875	4.125	4.562	2.062	0.500
3.000	4.250	4.687	2.062	0.500
3.125	4.562	5.000	2.187	0.500
3.250	4.687	5.125	2.187	0.500
3.375	4.812	5.250	2.187	0.500
3.500	4.937	5.500	2.187	0.500
3.625	5.125	5.687	2.312	0.562
3.750	5.250	5.812	2.312	0.562
3.875	5.437	6.000	2.312	0.562
4.000	5.562	6.125	2.312	0.562



TYPE 2/2B

Elastomer Bellows Seals

Type 2B Typical Arrangement/Dimensional Data

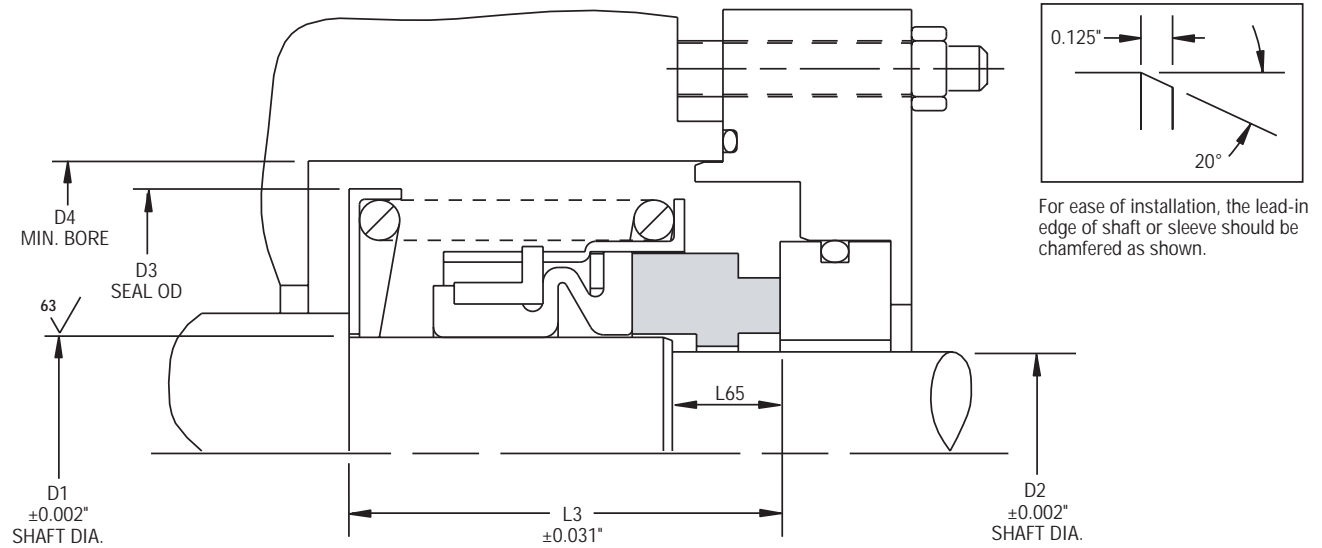

Type 2B Dimensional Data (inches)

Seal Size/D1 (inches)	D2	D3	D4	L3	L65
1.000	0.875	1.812	2.000	1.312	0.343
1.125	1.000	1.937	2.125	1.375	0.343
1.250	1.125	2.062	2.250	1.375	0.343
1.375	1.250	2.250	2.437	1.437	0.343
1.500	1.375	2.375	2.562	1.437	0.343
1.625	1.500	2.718	2.937	1.750	0.437
1.750	1.625	2.750	3.062	1.750	0.437
1.875	1.750	2.875	3.187	1.875	0.437
2.000	1.875	3.000	3.312	1.875	0.437
2.125	2.000	3.250	3.625	2.062	0.500
2.250	2.125	3.375	3.750	2.062	0.500
2.375	2.250	3.500	3.875	2.187	0.500
2.500	2.375	3.625	4.000	2.187	0.500
2.625	2.500	3.875	4.312	2.312	0.562
2.750	2.625	4.000	4.437	2.312	0.562
2.875	2.750	4.125	4.562	2.437	0.562
3.000	2.875	4.250	4.687	2.437	0.562
3.125	2.875	4.562	5.000	2.562	0.625
3.250	3.000	4.687	5.125	2.562	0.625
3.375	3.125	4.812	5.250	2.562	0.625
3.500	3.250	4.937	5.500	2.562	0.625
3.625	3.375	5.125	5.687	2.687	0.625
3.750	3.500	5.250	5.812	2.687	0.625
3.875	3.625	5.437	6.000	2.812	0.625
4.000	3.750	5.562	6.125	2.812	0.625



TYPE 2/2B

Elastomer Bellows Seals

Basic Pressure Rating

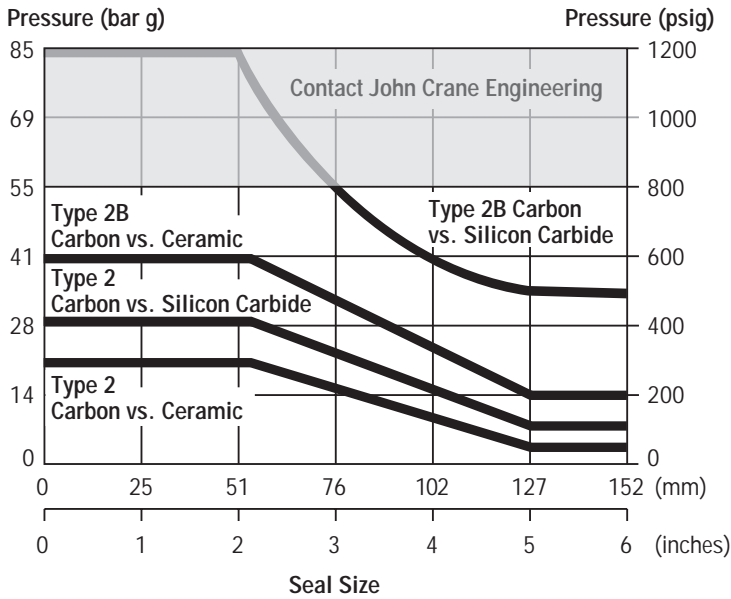

To determine the maximum pressure for the Type 2 or 2B required, multiply the maximum pressure by the Multiplier Factors to obtain the maximum operating pressure.

The Basic Pressure Rating is based on a standard Type 2 or Type 2B seal installed according to the criteria given in this data sheet and according to generally accepted industrial practices. The Basic Pressure Rating assumes stable operation at 1800 rpm in a clean, cool, lubricating, non-volatile liquid, with an adequate flush rate. When used with the Multiplier Factors, the Basic Pressure Rating can provide a conservative estimate of the dynamic pressure rating.

Contact John Crane Engineering for process services outside this range and with more detailed application information in order to obtain the actual dynamic pressure rating.

Multiplier Factors

	Selection Considerations	Multiplier Factor
Speed	1800 rpm Above 1800 rpm	x 1.00 *
Sealed Fluid Lubricity	Petrol/Gasoline, Kerosene, or Better Water and Aqueous Solutions Flashing Hydrocarbons** (Specific Gravity <0.65)	x 1.00 x 0.75 x 0.60
Sealed Fluid Temperature (for carbon only)	Below 79°C/175°F From 79°C to 121°C/175°F to 250°F From 121°C to 177°C/250°F to 350°F Above 177°C/350°F	x 1.00 x 0.90 x 0.80 x 0.65

Example for Determining Pressure Rating Limits:

Seal: 76mm/3" diameter Type 2B

Product: Water

Face Material: Carbon vs. Silicon Carbide

Temperature: 16°C/60°F

Shaft Speed: 1800 rpm

Using the Basic Pressure Rating chart, the maximum pressure would be 55 bar g/800 psig.

From the Multiplier Factors chart, apply the multipliers for the specific service requirements to determine the maximum dynamic pressure rating for the application.

$$55 \text{ bar g/800 psig} \times 1 \times 0.75 \times 1 = 41 \text{ bar g/600 psig}$$

At 1800 rpm with the service conditions noted, a 76mm/3" diameter Type 2B seal has a dynamic pressure rating of 41 bar g/600 psig. If operating pressure exceeds this dynamic rating, consult your John Crane Sales/Service Engineer.

* Multiplier = 1800/new speed Example: If new speed = 2700 rpm
Multiplier = 1800/2700 = 0.67

** The ratio of sealed pressure to vapor pressure must be greater than 1.5, otherwise consult John Crane. If the specific gravity is less than 0.60, consult John Crane.



TYPE 2/2B

Elastomer Bellows Seals

Breakout (Starting) Torque Consumption for Seal

For Starting Torque Power Consumption, consult John Crane Engineering.

Hydrostatic Pressure Limits

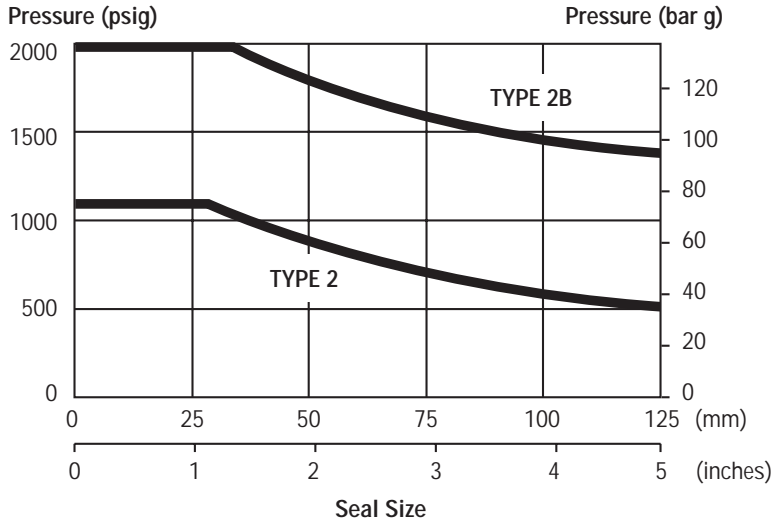

Speed Limits for Coil Springs

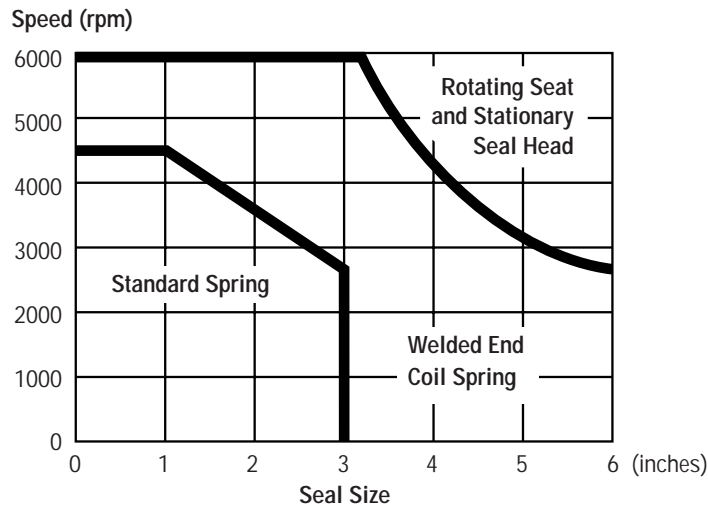

Criteria for Installation

Shaft/Sleeve	Limits
Surface Finish	1.00" to 3.125" dia. / 63 Ra 3.125" dia. & up / 32 Ra
Ovality/Out of Roundness (Shaft)	0.051mm/0.002"
End Play/Axial Float Allowance	±0.13mm/0.005"



TYPE 2/2B

Elastomer Bellows Seals

Materials of Construction

SEAL COMPONENTS	MATERIALS	
	Description	Standard
Face/Primary Ring	Carbon	Antimony-Impregnated Carbon Tungsten Carbide Silicon Carbide
Retainer Drive Band Disc Spring Holder	18-8 Stainless Steel	Monel® Alloy 20 CB-3 Stainless Steel 316 Stainless Steel
Bellows	Buna-N	Aflas® Fluoroelastomer Ethylene Propylene Neoprene® (Chloroprene)
Springs	18-8 Stainless Steel	Monel Alloy 20 CB-3 Stainless Steel 316 Stainless Steel

Aflas is a registered trademark of the Asahi Glass Co. Ltd.
 Monel is a registered trademark of Inco Alloys International, Inc.
 Neoprene is a registered trademark of DuPont.

Application Criteria

Type 2/2B elastomer bellows seals can be customized for specific installations after review and evaluation by John Crane Engineering. The following data is needed to evaluate the proposed service:

- Make and Model of Equipment
- Shaft or Sleeve OD
- Direction of Shaft Rotation
Viewed from Drive End
- Seal Cavity Dimensions
- Speed
- Process Fluid
 - Specific Gravity
 - Box Pressure
 - Vapor Pressure
 - Temperature
 - Viscosity



Europe
Slough, UK

Tel: 44-1753-224000
Fax: 44-1753-224224

Latin America
São Paulo, Brazil

Tel: 55-11-3371-2500
Fax: 55-11-3371-2599

Middle East, Africa, Asia
Dubai, United Arab Emirates

Tel: 971-4-3438940
Fax: 971-4-3438970

North America
Morton Grove, Illinois USA

1-800-SEALING
Tel: 1-847-967-2400
Fax: 1-847-967-3915

smiths

A part of Smiths Group plc

For your nearest John Crane facility, please contact one of the locations above.

If the products featured will be used in a potentially dangerous and/or hazardous process, your John Crane representative should be consulted prior to their selection and use. In the interest of continuous development, John Crane Companies reserve the right to alter designs and specifications without prior notice. It is dangerous to smoke while handling products made from PTFE. Old and new PTFE products must not be incinerated.

2-4

Pressure Switchgauge Information

Not Applicable on this order

2-5

Vibration Switchgage Information

Vibration Transmitters

ST5484E Velocity 4-20 mA



ATEX



SEISMIC PRODUCTS

Features

- Loop-powered
- 4-20 mA proportional to velocity
- Loop terminals w/Independent Polarity (IPT®)*. Prevents incorrect wiring
- Interfaces with PLC, DCS, 4-20 mA monitors
- Different mounting studs available
- Available with flying leads, terminal block or MIL style connector
- Highest operating temperature
- Most stable detection circuit
- Temperature shock protected
- "Ski slope"² problem protected
- Widest frequency range
- High & low pass filters options
- Built-in base & housing strain protection
- Extremely low cross axis sensitivity
- Dynamic signal option

Applications

- Blowers
- Centrifuges
- Compressors
- Engines
- Fans
- Generators
- Motors
- Pumps
- Turbines
- Turbochargers

Loop-powered Transmitter

Model ST5484E is the ideal solution for sensing vibration on most plant equipment. This precision case mounted vibration sensor and signal conditioner in a single package is built to provide years of reliable service. A simple two-wire loop signal proportional to velocity is generated for transfer to a programmable logic controller (PLC), distributed control system (DCS) or other 4-20 mA input devices. Simply mount the transmitter on the machine case, connect the 2-wire loop and read and/or record the vibration. Model ST5484E is made with our patented IPT® technology which eliminates wiring polarity errors.

*Note:

1. IPT® (Independent Polarity Terminal) is a registered trademark of Metrix Instrument Co.
2. See Accelerometer Application Note on page 6.12.

Specifications

Vibration Range: 4 to 20 mA output proportional to velocity. Refer to "How to Select A" for ranges. Nonstandard ranges available.
Accuracy: 2% (Repeatability)
Dynamic Signal: Acceleration, 100 mV/g. The dynamic signal has the same frequency range as in "How to Select E/F". 12dB / oct high pass and 12 dB / oct low pass response.
Frequency Response: Standard: 2 - 1500 Hz, available up to 2000 Hz. Refer to "How to Select E/F". 12 dB / oct high pass and low pass filters are used.
Axis Orientation: Any
Supply Voltage (Vs): 11 to 30 VDC,

Non-polarity sensitive, IPT®
Isolation: 500Vrms, circuit to case
Electrical Connection Options:

- Flying leads w/18 AWG wire 457 mm (24 in.) long.
- MIL style 2-pin connector.
- Terminal block (accepts up to 16 AWG wire)

Maximum Load Resistance (R_L): R_L = 50 x (V_{supply}-11) ohms
Service Temp. Rating: -40° to 100°C (-40°F to 212°F)
Enclosure Materials: 303 SS
Enclosure Environmental Rating: NEMA 4X, IP 65, IP 67 for 2 pin style connector
Approvals: Refer to "How to Select C".

Weight & Dimensions

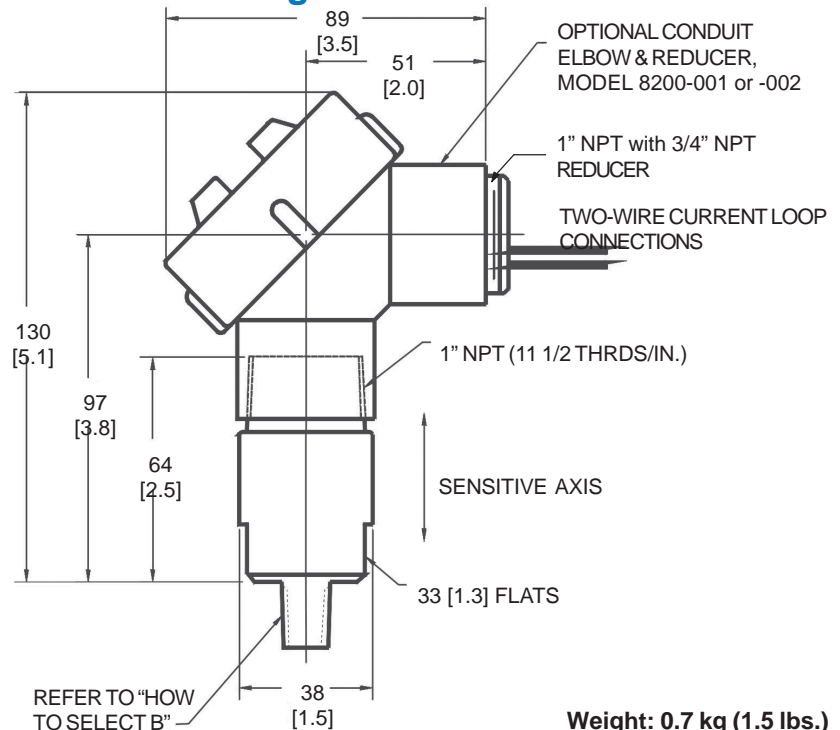

Weight: 0.7 kg (1.5 lbs.)



ST5484E-XXX-X20-XX
With 2-24" flying leads.

ST5484E-XXX-X21-XX
With 4-24" flying leads. The dynamic signal leads (black & white) provide a buffered 100 mV/g connection for analysis.

ST5484E-XXX-X32-XX
With two slot terminal block.



ST5484E-XXX-X33-XX
Four slot terminal block top connection. The dynamic signal terminals (two outside ones) provide a buffered 100 mV/g connection for analysis.



ST5484E-XXX-X14-XX
With 2-pin MIL style connector.



How To Select...

ST5484E - - -

A **Full Scale Range**

1	2	1	= 1 ips (25 mm/s), pk
1	2	2	= 0.5 ips (12.7 mm/s), pk
1	2	3	= 2.0 ips (50 mm/s), pk
1	2	4	= 5.0 ips (125 mm/s), pk
1	3	2	= 3.0 ips (75 mm/s), pk
1	5	1	= 1 ips (25 mm/s), rms
1	5	2	= 0.5 ips (12.7 mm/s), rms
1	5	3	= 2.0 ips (50 mm/s), rms
1	5	4	= 5.0 ips (125 mm/s), rms
1	6	2	= 3.0 ips (75 mm/s), rms

Note: For true RMS velocity calibration, add 30 to dash number. Ex: -121 becomes -151.

B **Mounting Stud**

0	= Integral 1/4" NPT
1	= Integral 1/2" NPT
2	= 3/8 - 24 UNF X 1/2"
3	= 1/2 - 20 UNF X 1/2"
4	= M8 X 1-12
5	= M10 X 1.25-12

C **Hazard Rating**

1	= Non-hazardous & CSA/NRTL/C (for all connections) Class I, Div 2, Grps A,B,C & D
2	= CSA/NRTL/C for Class I, Div 1, Grps B-D & Class II, Div 1, Grps E-G (available with flying leads ONLY)
3	= ATEX, EEx ia IIC T4 Intrinsically Safe (available with terminal block or 2-pin MS connector)

D **Connection**

0	= 4-20 mA: Flying leads (C = 1 or 2)
1	= 4-20 mA and dynamic signal: Flying leads (C = 1 or 2)
2	= 4-20 mA: 2-pin terminal block (C = 1 or 3)
3	= 4-20 mA and dynamic signal: 4-pin terminal block (C = 1 or 3)
4	= 4-20 mA: 2-pin MIL style connector (C = 1 or 3)

E **High Pass Filter**

0	= No Filter (2 Hz), Standard
1	= 5 Hz
2	= 10 Hz
3	= 20 Hz
4	= 50 Hz
5	= 100 Hz
6	= 200 Hz

F **Low Pass Filter**

0	= No Filter (1500 Hz), Standard
1	= 500 Hz
2	= 1000 Hz
3	= 2000 Hz

	<p>8200-001, Conduit Elbow & Reducer Provides access and physical protection for field wiring. Suitable for Class I, Div. 1 (Grps C & D) and Class II, Div. 1 (Grps E, F & G), hazardous areas. 1" to 3/4" NPT reducer for customer connection included. NEMA 4 IP 65. Material: copper free aluminum.</p>
	<p>8200-002, Conduit Elbow & Reducer Conduit Elbow with terminal block</p>
	<p>8200-005, Stainless Steel Conduit Elbow & Reducer Provides access and physical protection for field wiring. 1/2" NPT suitable for Class I, Div. 1 (Grps B, C & D)*, Class II, Div. 1 (Grps E, F & G)*. Material: stainless steel</p>
	<p>8200-006, Conduit Elbow & Reducer Stainless Steel Conduit Elbow with terminal block</p>
	<p>8201-001, Conduit Union Fits between transmitter and 8200-001 conduit elbow to facilitate installation and wiring where there is not enough room to rotate the elbow. Suitable for Class I, Div. 1 (Grps A, B, C & D) and Class II, Div. 1 (Grps E, F & G), hazardous areas. Material: zinc plated steel.</p>
	<p>7084-001, Stainless Steel Flange Mount Adaptor Provides a means to surface mount transmitters rather than NPT stud (1/2": NPT center hole). Three equally spaced 6.6 mm (0.26") diameter mounting holes on 38 mm (1.50") diameter circle.</p>
	<p>7084-002, Flange Mount Adaptor Same as 7084-001, except center hole is 1/4" NPT. Material: stainless steel</p>
	<p>8253-002, Bushing Bushing for 1/2" NPT mount when screwed onto standard 1/4" NPT base. Material: stainless steel.</p>
	<p>8169-75-002-XXX, Two-wire, Cable Assembly 2 conductor (20 AWG) twisted, shielded PVC jacketed cable, with plated steel grip for cable strain relief, male 3/4" NPT end. Specify -XXX for length in feet. Example: 8169-75-002-010 =10 ft (3.1M). Material: zinc plated steel.</p>
	<p>8978-111-XXXX, Splashproof Cable Assembly Two (2) pin socket connector with integral, molded splash proof boot with 6.4 mm (0.25") diameter polyurethane jacketed cable with twisted shielded pair wires. xxx.x = Cable length in meters.</p>
	<p>9334-111-XXXX-YYYY, Splashproof Cable Assembly w/Stainless Steel Armor Two (2) pin socket connector with integral, molded splash proof boot with 7.1 mm (0.28") diameter, SST armored jacket with cable, twisted shielded pair wires. xxx.x = Armor length in meters. yyy.y = Cable length in meters.</p>
	<p>8978-211-XXXX, Cable Assembly Two (2) pin socket connector with cable strain relief with 6.4 mm (0.25") diameter polyurethane jacketed cable with twisted shielded pair wires. xxx.x = Cable length in meters.</p> <p>Note: All 8978 connector/cable assemblies rated to 121°C (250°F) max.</p>
	<p>9334-211-XXXX-YYYY, Cable Assembly, w/Stainless Steel Armor Two (2) pin socket connector with 7.1 mm (0.28") diameter, SST armored jacket with cable, twisted shielded pair wires. xxx.x = Armor length in meters. yyy.y = Cable length in meters.</p>
	<p>8978-200-0000, Connector Assembly Two (2) pin socket connector with cable strain relief, no cable.</p>
	<p>93818-004, Cable Grip Strain Relief Fitting 3/4" NPT male thread to cable grip. Diameter range: .156" to .25". Complete with sealing ring and locknut. Hot dip / mechanically galvanized finish. Suitable for NEMA 4 enclosures.</p>
	<p>93818-018, Armored Cable Grip Strain Relief Fitting 3/4" NPT male thread to cable grip. Armor diameter range: .40" to .50". Complete with sealing ring and locknut. Hot dip / mechanically galvanized finish. Suitable for NEMA 4 enclosures.</p>

* Pending

Level Switchgag[®] Instrument For Engine Liquids

LEL-00072B
Revised 06-06
Catalog Section 15



L150/ EL150K1 Series

- Monitors Level of Coolant, Lube Oil, Diesel Fuel And Hydraulic Fluid.
- Indicating Gauge
- Low Limit Switch
- Float Operated
- Explosion-Proof Model Is Available.



** Products covered by this bulletin comply with EMC Council directive 89/336/EEC regarding electromagnetic compatibility except as noted.

EL150EX Models are CSA Listed for Class I, Division 1, Group C & D Hazardous Locations.

Description

The L150 Series Level Switchgag instrument is a combination liquid level gauge and low limit switch; each unit includes (1) a chamber with pivotal float, (2) an indicating dial with pointer, and (3) a low level contact. When properly installed and maintained, the float operates the pointer which, in turn, both indicates level during normal operation, and closes a switching circuit if the level falls to the low-limit set point.

Applications

The primary use of the L150/EL150K1 is for engine cooling systems, surge or expansion tanks, condenser radiator or vapor phase systems, pressurized or atmospheric systems. The Level Switchgag instrument can also be used to monitor lube oil, hydraulic fluid or diesel fuel reservoirs and activates alarms and/or shut-down at a predetermined minimum level.

These instruments are built for low pressure systems with a maximum of 25 psi (172 kPa) [1.72 bar].

L150 Specifications

Case: Die cast aluminum, poly-urethane coated; approximate dimensions; 4-1/2 x 4-3/4 x 2-3/4 in. (114 x 121 x 70 mm).

Mounting Holes: (2) 9/32 in. (7 mm) diameter at 4-1/2 in. (114 mm) on center.

Float: Brass.

Lens: Polycarbonate.

O-rings: Saturated Nitrile, are suitable for coolant or hydrocarbons. Maximum temperature 250°F (121°C).

Gasket: Nitrile.

Vent Tube: 1/4 x 5 in. (6 x 127 mm) copper cane with 1/4 NPT x 1/4 in. (6 mm) tube fitting.

Contact Rating: 2 A @ 30 VAC/DC.

Wire: (1) 16 AWG x 26 in. (1.5 mm² x 660 mm) with terminals.

Shipping Weight: 29 oz. (0.82 kg.).

Shipping Dimensions: 5-1/4 x 5-1/4 x 5-1/2 in. (133 x 133 x 140 mm).

EL150K1 Specifications

Case: Die cast aluminum, poly-urethane coated; approximate dimensions; 5 x 4-3/4 x 2-3/4 in. (127 x 121 x 70 mm).

Mounting Holes: (2) 9/32 in. (7 mm) diameter at 4-1/2 in. (114 mm) on center.

Float: Brass.

Lens: Polycarbonate.

O-rings: Saturated Nitrile, are suitable for coolant or hydrocarbons. Maximum temperature 250°F (121°C).

Gasket: Nitrile.

Vent Tube: 1/4 x 5 in. (6 x 127 mm) copper cane with 1/4 NPT x 1/4 in. (6 mm) tube fitting.

Snap-Switch: SPDT rated 10 A @ 125 VAC; 0.5 A @ 125 VDC; 10 A 30 VDC.

Wire: (3) 18 AWG x 14 in. (1 mm² x 356 mm).

Shipping Weight: 42 oz. (1.2 kg.).

Shipping Dimensions: 5-1/4 x 5-1/4 x 5-1/2 in. (133 x 133 x 140 mm).

EL150EX Specifications

Case: Sand cast aluminum, painted; approximate dimensions; 6-1/2 x 5-3/4 x 5-1/4 in. (165 x 146 x 133 mm).

Mounting Holes: (2) 5/16 in. (8 mm) diameter at 5-1/2 in. (140 mm) on center.

Float: 304 Stainless steel.

Lens: Tempered glass.

O-rings: Saturated Nitrile, are suitable for coolant or hydrocarbons. Maximum temperature 250°F (121°C).

Gasket: Nitrile.

Vent Tube: 1/4 x 5 in. (6 x 127 mm) copper cane with 1/4 NPT x 1/4 in. (6 mm) tube fitting and 1/2 NPT to 1/4 NPT reducer fitting.

Snap-Switch: SPDT rated 10 A @ 125 VAC; 0.5 A @ 125 VDC; 10 A 30 VDC.

Wire: Wired to terminal block.

Laboratory Approvals: CSA Listed for Hazardous Locations Class I, Division 1, Groups C & D.

Shipping Weight: 5 lbs. (2.26 kg.).

Shipping Dimensions: 6-1/2 x 6-3/4 x 6-3/8 in. (165 x 171 x 162 mm).



Thermocouple, RTD, and RTD Transmitter Assemblies With Thermowell

TA-96084B
Revised 07-04
Catalog Section 10
(00-02-0773)



TC, RTD, and RTDT Series

- 304 Stainless Steel Thermowell Protection
- Compatible with Digital SWICHGAGE®
- Types J or K Ungrounded Thermocouples
- 100 Ohm, 3-Wire RTD Assemblies
- 4-20 mA DC Output RTD Transmitters

Description

Murphy offers a variety of highly reliable thermocouple and RTD (Resistance Temperature Detector) assemblies and 4-20 mA DC output RTD transmitters.

Their innovative features include a 304 stainless steel thermowell that provides protection to the spring-loaded element.

The cast aluminum connecting head meets NEMA 4 requirements and includes an RTD transmitter or a thermocouple/RTD terminal block mounted on ceramic Steatite and rated NEC Class 2.

The complete assemblies are offered in 2-1/2, 4-1/2, or 7-1/2 in. (63, 114, or 191 mm) thermowell insertion lengths.

Thermocouple Assemblies with Thermowell

Available in types J or K, the thermocouple assemblies have ungrounded elements in a 304 stainless steel spring loaded sheath. For product compatibility see back page (replacement parts and thermocouple extension wire are available).

RTD Assemblies with Thermowell

Resistance temperature detector (RTD) assemblies are available with a 100 ohm platinum element, 3-wire leads, and spring loaded 316L stainless steel element sheath.

RTD Transmitter Assemblies with Thermowell

RTDT assemblies transmit process variable temperatures. Available as part of the temperature sensor assemblies or as a separate units, the RTDT's accept 2 or 3 wire, 100 ohm RTD's. The RTD transmitters are loop powered, they feature linearized 4-20 mA DC outputs and have reversed polarity protection.

Applications

Murphy's temperature sensing assemblies fit in a variety of industrial processes and applications. Their ruggedness and characteristics make these assemblies a popular and price-competitive choice.

Specifications

Thermowell: 304 stainless steel; 7000 psi (48.2 MPa) [482 bar] max. @ 70°F.

Connecting Head: Cast Aluminum; 400°F (204°C) maximum operating temperature.

Thermocouple: Ungrounded, Magnesium Oxide (MgO) insulated 96% purity; element sheath of 304 stainless steel.

Type "J" operating temp.: 900°F (482°C) max.

Type "K" operating temp.: 1800°F (982°C) max.

RTD: 100 ohm @ 0°C Platinum element; 3-wire; 400 °F maximum; 0.00385 temperature coefficient; 316L stainless steel element sheath.

RTD Transmitter: 100 ohms Platinum RTD; 400 °F maximum; Ranges: 0 to 400°F and -60 to 140°F. Linearized 4-20 mA DC output. Loop powered typically 24 VDC, when using the Loop Resistance Graph, 13-40 VDC. For use with 100 ohms Platinum RTD elements, 0.00385 temperature coefficient.

Thermocouple Accuracy (J/K): 0.5%.

RTD Accuracy: ±0.12%.

RTD Transmitter Accuracy: ±0.1%.

Terminal block: Ceramic Steatite; thermocouples have: 4 terminals; RTD's: 6 terminals. 28 to 14 AWG wire size, (8-32 SS screws).

Shipping Weights (listed by insertion length):

2-1/2 in. (63 mm) model: 2 lb. (0.907 kg).

4-1/2 in. (114 mm) model: 2 lb. 8oz. (1.24 kg).

7-1/2 in. (191 mm) model: 3 lb. 6oz. (1.67 kg).

Shipping Dimensions (listed by insertion length):

2-1/2 and 4-1/2 in (63 and 114 mm) models:

12 x 7 x 5-1/2 in. (305 x 178 x 140 mm).

7-1/2 in. (191 mm) models: 16 x 11 x 5-1/2 in. (406 x 280 x 144 mm).

Optional Thermocouple Extension Wire:

(Sold separately—see How to Order section)

Individual Conductor Insulation: *Extruded PFA*.

Duplex Conductor Insulation: *Twisted; Extruded PFA Overall*.

Temperature Rating: *Continuous -450 to 500°F (-267 to 260°C).*

Abrasion Resistance: *Good.*

Moisture Resistance: *Excellent.*

Shielding: *Metallic Shield.*

Gauge: *20 AWG (0.5 mm²).*

Ohms per Double Foot Type "J": *0.357*

Ohms per Double Foot Type "K": *0.586*

Warranty

A limited warranty on materials and workmanship is given with this FW Murphy product. A copy of the warranty may be viewed or printed by going to www.fwmurphy.com/support/warranty.htm

Loop Resistance Graph

Supply voltage for RTDT must be within 13-40 VDC. The figure below shows the minimum supply voltage (VDC) required for a given load resistance (RL).

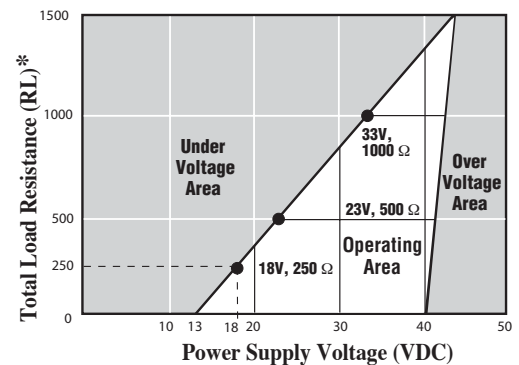

*NOTE: Cable resistance effect included in RL.



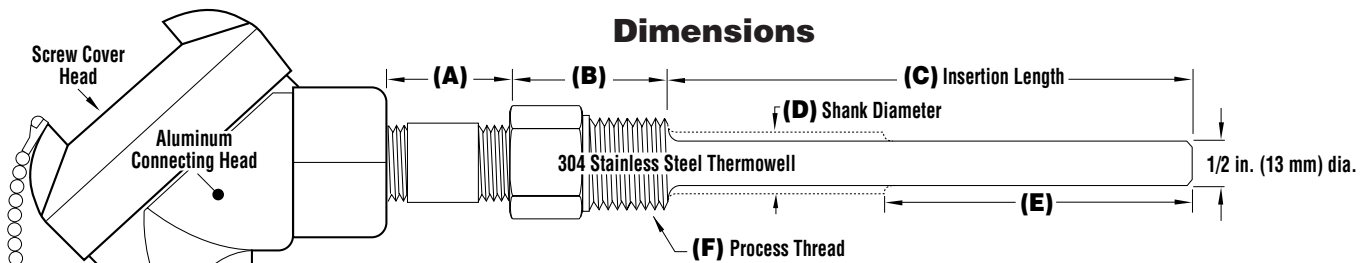

Model Number	(A)	(B)	(C)	(D)	(E)	(F)
TCJ-225, TCK-225, RTD-225-400-100, RTDT-225-400-100, RTDT-225-140-100	1 in. (25 mm)	1-3/4 in. (44 mm)	2-1/2 in. (63 mm)	N/A	N/A	1/2 NPT
TCJ-325, TCK-325, RTD-325-400-100, RTDT-325-400-100, RTDT-325-140-100	1 in. (25 mm)	1-3/4 in. (44 mm)	2-1/2 in. (63 mm)	N/A	N/A	3/4 NPT
TCJ-245, TCK-245, RTD-245-400-100, RTDT-245-400-100, RTDT-245-140-100	1 in. (25 mm)	1-3/4 in. (44 mm)	4-1/2 in. (114 mm)	5/8 in. (16 mm)	2-1/2 in. (64 mm)	1/2 NPT
TCJ-345, TCK-345, RTD-345-400-100, RTDT-345-400-100, RTDT-345-140-100	1 in. (25 mm)	1-3/4 in. (44 mm)	4-1/2 in. (114 mm)	5/8 in. (16 mm)	2-1/2 in. (64 mm)	3/4 NPT
TCJ-275, TCK-275, RTD-275-400-100, RTDT-275-400-100, RTDT-275-140-100	1 in. (25 mm)	1-3/4 in. (44 mm)	7-1/2 in. (191 mm)	5/8 in. (16 mm)	2-1/2 in. (64 mm)	1/2 NPT
TCJ-375, TCK-375, RTD-375-400-100, RTDT-375-400-100, RTDT-375-140-100	1 in. (25 mm)	1-3/4 in. (44 mm)	7-1/2 in. (191 mm)	5/8 in. (16 mm)	2-1/2 in. (64 mm)	3/4 NPT

How to Order

To order just specify the model number needed (see chart below). Order replacement parts and thermocouple extension wire separately.

Model Number	P. Thread	Insertion Length	Sensing Element Type	Transmitter Range
Thermocouple Assemblies (thermowell included)				
TCJ-225	1/2 NPT	2-1/2 in. (63 mm)	J Type Ungrounded Thermocouple	
TCK-225	1/2 NPT	2-1/2 in. (63 mm)	K Type Ungrounded Thermocouple	
TCJ-325	3/4 NPT	2-1/2 in. (63 mm)	J Type Ungrounded Thermocouple	
TCK-325	3/4 NPT	2-1/2 in. (63 mm)	K Type Ungrounded Thermocouple	
TCJ-245	1/2 NPT	4-1/2 in. (114 mm)	J Type Ungrounded Thermocouple	
TCK-245	1/2 NPT	4-1/2 in. (114 mm)	K Type Ungrounded Thermocouple	
TCJ-345	3/4 NPT	4-1/2 in. (114 mm)	J Type Ungrounded Thermocouple	
TCK-345	3/4 NPT	4-1/2 in. (114 mm)	K Type Ungrounded Thermocouple	
TCJ-275	1/2 NPT	7-1/2 in. (191 mm)	J Type Ungrounded Thermocouple	
TCK-275	1/2 NPT	7-1/2 in. (191 mm)	K Type Ungrounded Thermocouple	
TCJ-375	3/4 NPT	7-1/2 in. (191 mm)	J Type Ungrounded Thermocouple	
TCK-375	3/4 NPT	7-1/2 in. (191 mm)	K Type Ungrounded Thermocouple	
RTD Assemblies (thermowell included)				
RTD-225-400-100	1/2 NPT	2-1/2 in. (63 mm)	100 ohm Pt RTD 400°F maximum	
RTD-325-400-100	3/4 NPT	2-1/2 in. (63 mm)	100 ohm Pt RTD 400°F maximum	
RTD-245-400-100	1/2 NPT	4-1/2 in. (114 mm)	100 ohm Pt RTD 400°F maximum	
RTD-345-400-100	3/4 NPT	4-1/2 in. (114 mm)	100 ohm Pt RTD 400°F maximum	
RTD-275-400-100	1/2 NPT	7-1/2 in. (191 mm)	100 ohm Pt RTD 400°F maximum	
RTD-375-400-100	3/4 NPT	7-1/2 in. (191 mm)	100 ohm Pt RTD 400°F maximum	
RTD Transmitter Assemblies (thermowell included)				
RTDT-225-400-100	1/2 NPT	2-1/2 in. (63 mm)	100 ohm Pt 4-20 mA RTD Transmitter	0-400°F (-17.8 to 204°C)
RTDT-225-140-100	1/2 NPT	2-1/2 in. (63 mm)	100 ohm Pt 4-20 mA RTD Transmitter	-60 to 140°F (-51.1 to 60°C)
RTDT-325-400-100	3/4 NPT	2-1/2 in. (63 mm)	100 ohm Pt 4-20 mA RTD Transmitter	0-400°F (-17.8 to 204°C)
RTDT-325-140-100	3/4 NPT	2-1/2 in. (63 mm)	100 ohm Pt 4-20 mA RTD Transmitter	-60 to 140°F (-51.1 to 60°C)
RTDT-245-400-100	1/2 NPT	4-1/2 in. (114 mm)	100 ohm Pt 4-20 mA RTD Transmitter	0-400°F (-17.8 to 204°C)
RTDT-245-140-100	1/2 NPT	4-1/2 in. (114 mm)	100 ohm Pt 4-20 mA RTD Transmitter	-60 to 140°F (-51.1 to 60°C)
RTDT-345-400-100	3/4 NPT	4-1/2 in. (114 mm)	100 ohm Pt 4-20 mA RTD Transmitter	0-400°F (-17.8 to 204°C)
RTDT-345-140-100	3/4 NPT	4-1/2 in. (114 mm)	100 ohm Pt 4-20 mA RTD Transmitter	-60 to 140°F (-51.1 to 60°C)
RTDT-275-400-100	1/2 NPT	7-1/2 in. (191 mm)	100 ohm Pt 4-20 mA RTD Transmitter	0-400°F (-17.8 to 204°C)
RTDT-275-140-100	1/2 NPT	7-1/2 in. (191 mm)	100 ohm Pt 4-20 mA RTD Transmitter	-60 to 140°F (-51.1 to 60°C)
RTDT-375-400-100	3/4 NPT	7-1/2 in. (191 mm)	100 ohm Pt 4-20 mA RTD Transmitter	0-400°F (-17.8 to 204°C)
RTDT-375-140-100	3/4 NPT	7-1/2 in. (191 mm)	100 ohm Pt 4-20 mA RTD Transmitter	-60 to 140°F (-51.1 to 60°C)

Replacement Parts (order separately)

- TCHA = Cast aluminum head with terminal blocks for thermocouples
- TCJE-25 = Type J element only for 2-1/2 in. wells*
- TCKE-25 = Type K element only for 2-1/2 in. wells*
- TCJE-45 = Type J element only for 4-1/2 in. wells*
- TCKE-45 = Type K element only for 4-1/2 in. wells*
- TCJE-75 = Type J element only for 7-1/2 in. wells*
- TCKE-75 = Type K element only for 7-1/2 in. wells*
- PTW-225 = 1/2 NPT x 2-1/2 in. thermowell
- PTW-325 = 3/4 NPT x 2-1/2 in. thermowell
- PTW-245 = 1/2 NPT x 4-1/2 in. thermowell
- PTW-345 = 3/4 NPT x 4-1/2 in. thermowell
- PTW-275 = 1/2 NPT x 7-1/2 in. thermowell
- PTW-375 = 3/4 NPT x 7-1/2 in. thermowell
- RTDE-25 = 100 Ω Pt RTD element only for 2-1/2 in. wells*
- RTDE-45 = 100 Ω Pt RTD element only for 4-1/2 in. wells*
- RTDE-75 = 100 Ω Pt RTD element only for 7-1/2 in. wells*
- RTDTX-400-100 = 100 Ω Pt RTD Transmitter only (0 to 400°F)*
- RTDTX-140-100 = 100 Ω Pt RTD Transmitter only (-60 to 140°F)*

Thermocouple Extension Wire

- 00-00-3271 = Type J 100 ft roll.
- 00-00-3272 = Type K 100 ft roll.

* All elements are spring loaded

Product Compatibility

Model	Power Source	Temperature Sensor
MDTM89	CD Ign. 12/24 VDC, 120 VAC	J/K ungrounded thermocouples
TDX6	CD Ign. 12/24 VDC, 120 VAC	J/K grounded/ungrounded tc.
TD35	8-35 VDC	J/K grounded/ungrounded tc.
MDM45	10-30 VDC @ 3.6 watts max.	4-20 mA RTD transmitter
CS2001	12/24 VDC, 120/220 VAC	J/K ungrounded thermocouples, RTD transmitter / 3-wire RTD



FW Murphy
P.O. Box 470248
Tulsa, Oklahoma 74147 USA
+1 918 317 4100
fax +1 918 317 4266
e-mail sales@fwmurphy.com
www.fwmurphy.com

CONTROL SYSTEMS & SERVICES DIVISION
P.O. Box 1819; Rosenberg, Texas 77471; USA
+1 281 633 4500 fax +1 281 633 4588
e-mail sales@fwmurphy.com

MURPHY DE MEXICO, S.A. DE C.V.
Blvd. Antonio Rocha Cordero 300, Fracción del Aguaje
San Luis Potosí, S.L.P.; México 78384
+52 444 8206264 fax +52 444 8206336
Villahermosa Office +52 993 3162117
e-mail ventas@murphymex.com.mx
www.murphymex.com.mx

FRANK W. MURPHY, LTD.
Church Rd.; Laverstock, Salisbury SP1 1QZ; U.K.
+44 1722 410055 fax +44 1722 410088
e-mail sales@fwmurphy.co.uk
www.fwmurphy.co.uk

MURPHY SWITCH OF CALIFORNIA
41343 12th Street West
Palmdale, California 93551-1442; USA
+1 661 272 4700 fax +1 661 947 7570
e-mail sales@murphyswitch.com
www.murphyswitch.com

MACQUARRIE CORPORATION
1620 Hume Highway
Campbellfield, Vic 3061; Australia
+61 3 9358 5555 fax +61 3 9358 5558
e-mail murphy@macquarrie.com.au



In order to consistently bring you the highest quality, full featured products, we reserve the right to change our specifications and designs at any time.

2-6

Motor/Tc Coupling Information

- A – Stainless Steel Flexible Discs
- B – Overload Collars
- C – Cartridge Transmission Unit
- D – Anti-Fly Feature
- E – Anti-Corrosion Treatment
- F – Hubs with Puller Holes
- G – Externally Wrenched Bolts
- H – Jacking Bolt Feature

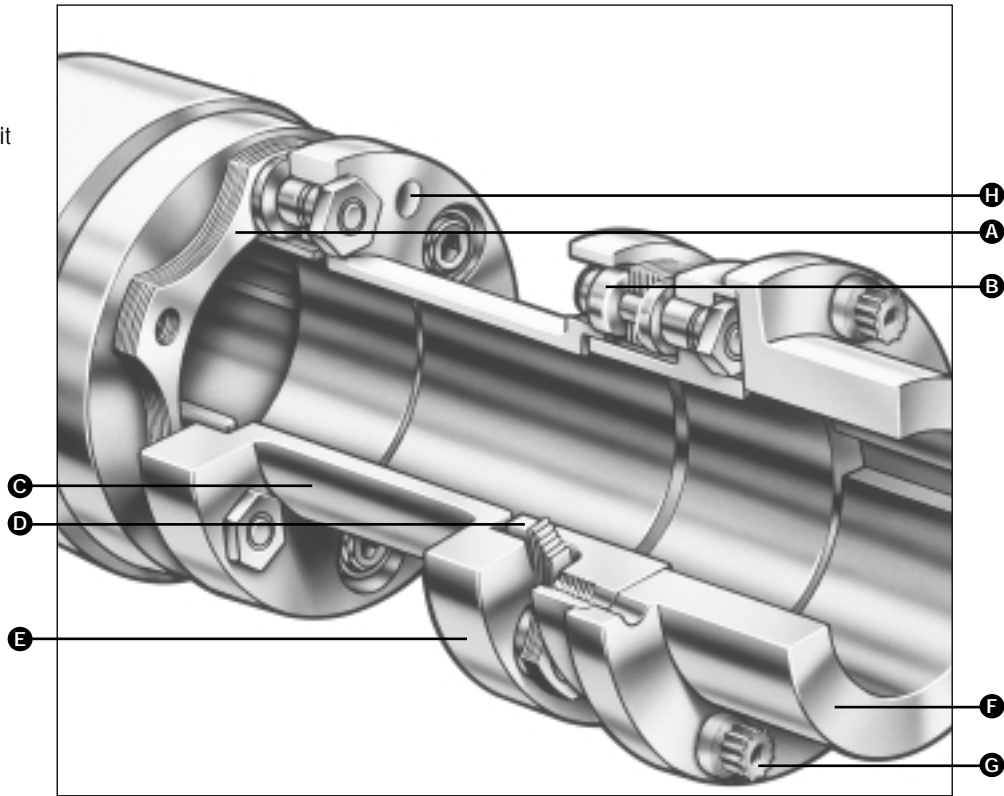

Product Description

Metastream® T Series Couplings, pioneered by John Crane Flexibox®, incorporate a scalloped, stainless steel flexible disc design. This design gives the most flexible solution for high torque and misalignment.

- Easy to fit.
- Meets API 610 8th edition. Can be supplied to meet API 671.
- Intrinsic balance meets AGMA class 9.
- Ideally suited for electric motors and turbine drives in critical process industry, marine, and power generation applications.

Design Features

- Excellent power-to-weight ratio.
- High misalignment capability.
- Low imposed forces on machinery leading to:
 - Reduced machinery vibration
 - Maximized bearing life
- Stainless steel flexible discs for maximum life.
- Cartridge transmission unit eases assembly and gives repeatable balance.
- Overload collars are fitted to protect the flexible discs in case of a more severe torsional overload.
- Anti-fly retention of the spacer in the unlikely event of flexible disc failure.
- Jacking bolt feature for easy installation and removal of spacer assembly.
- Puller holes incorporated into hubs as standard.



TSC

METASTREAM® T Series Couplings

TSC Technical Data

Coupling Size	Rating HP/100 rpm	Max.		Max. rpm	Weight - Transmission Unit (lb.)		Weight - Unbored Hub (lb.)		
		Continuous Torque lb. in.	Peak Overload Torque lb. in.		Minimum DBSE	Per Inch Extra DBSE	Standard	Large	Long
0013	1.7	1,068	2,670	25,500	3.0	0.2	1.9	4.0	-
0033	4.4	2,770	6,920	20,000	5.9	0.3	3.4	6.7	-
0075	10.0	6,300	15,750	16,500	11.2	0.4	7.5	12.6	8.2
0135	18.0	11,340	28,350	14,400	19.5	0.6	12.2	19.4	14.8
0230	31.0	19,520	48,800	12,000	28.1	0.7	19.4	30.6	24.4
0350	47.0	29,600	74,000	10,500	35.2	0.7	35.9	-	41.4
0500	67.0	42,200	105,000	9,500	44.2	0.9	46.2	-	57.6
0740	99.0	62,360	155,900	8,000	55.9	1.1	66.4	-	81.9
0930	125.0	78,740	196,850	7,000	71.7	1.3	85.0	-	110.7
1400	188.0	118,440	296,100	6,000	101.6	1.8	115.7	-	159.5

Note that for the complete coupling, weights of two appropriate hubs plus a transmission unit are required.

Hubs will be supplied unbored unless specified. Consult your local sales office regarding standard bore and keyway tolerances.

TSC Typical Arrangement

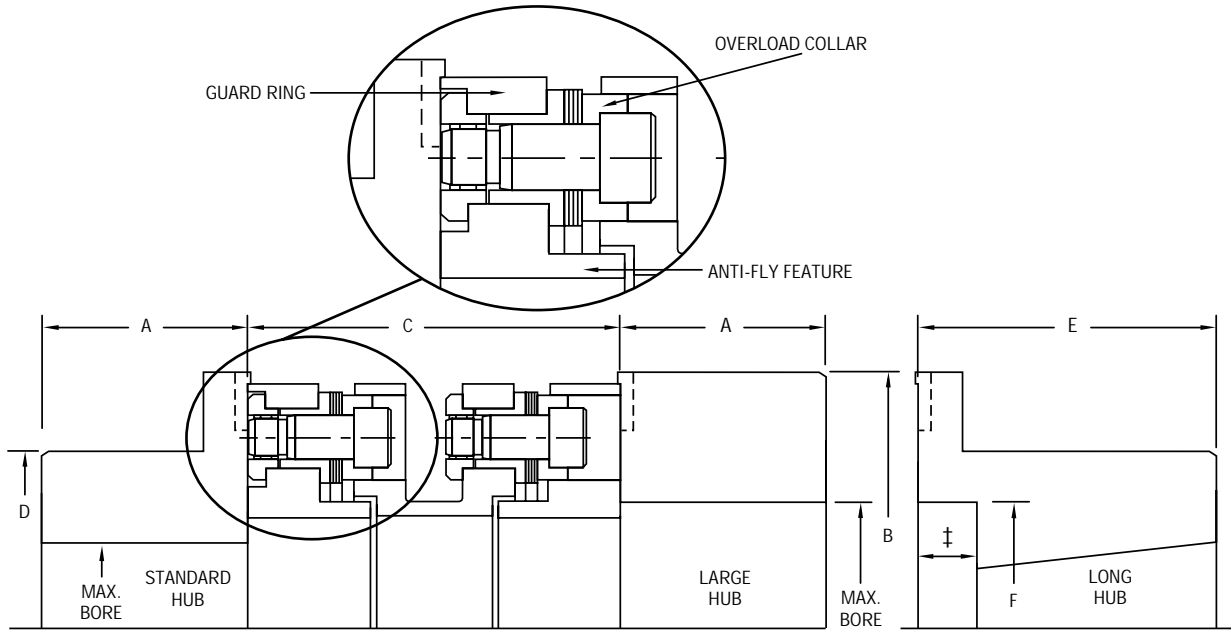

† To Suit Specific Applications

TSC Dimensional Data (inches)

Coupling Size	A	B	C		D	E	F	MAXIMUM BORES		
			Distance Between Shaft Ends Min.	Stocked*				Standard Hub**	Large Hub**	Long Hub***
0013	1.562	3.375	2.50	3.5, 4.375, 5.0, 7.0	2.125	-	-	1.375	2.000	-
0033	1.750	4.125	3.00	3.5, 4.375, 5.0, 7.0	2.750	-	-	1.750	2.750	-
0075	2.187	5.125	3.68	4.375, 5.0, 7.0	3.500	2.437	2.938	2.250	3.375	2.250
0135	2.437	6.000	4.56	5.0, 7.0	4.437	3.031	3.875	2.875	4.000	2.875
0230	2.750	7.000	4.81	7.0	5.187	3.593	4.625	3.375	4.750	3.375
0350	3.562	8.000	4.94	7.0	6.437	4.187	5.750	4.375	-	4.375
0500	3.750	9.000	5.00	7.0	7.125	4.750	6.500	4.625	-	4.625
0740	4.250	10.000	5.12	8.0	8.125	5.312	7.375	5.500	-	5.500
0930	4.500	11.000	5.50	9.0	8.750	6.031	8.000	5.750	-	5.750
1400	5.125	12.000	6.31	10.0	9.750	7.187	9.000	6.500	-	6.500

All dimensions in inches, and should not be used for construction. Certified dimensions furnished upon request.

NOTES: * These Distance Between Shaft End (DBSE) sizes are stocked. Other lengths to suit specific shaft separations are available.

** Maximum bores shown are based on standard AGMA square key dimensions.

*** Accommodates NEMA standards for taper bores.



TSC

METASTREAM® T Series Couplings

Selection Procedure

1. Select appropriate service factor SF from table.
2. Calculate coupling rating from

$$R = \frac{HP \times 100 \times SF}{N}$$
 where:
 HP = driver rated power (horsepower)
 N = speed (rev./min.)
3. Select a coupling with the same or higher rating.
4. Check that the hub bore capacity is suitable.
5. Check peak torque capability is suitable for application.
6. Check speed capability.
7. Check whether additional dynamic balancing is required.
8. Specify Distance Between Shaft Ends (DBSE).

Example: 150 HP electric motor to centrifugal pump at 3600 rpm.

$$R = \frac{150 \times 100 \times 1}{3600}$$

R = 4.17 HP per 100 rpm

Selection: TSC - 0033

Standard hub bore up to 1.75"
 Large hub bore up to 2.75"
 Peak torque capability: 6920 lb.-in.

Additional dynamic balancing should not be required.

Service Factor SF

Suggested service factors for electric motor, steam turbine, and gas turbine drivers are given below.

Torque Variation		Service Factor
Constant Torque	Centrifugal Pump Centrifugal Compressor Axial Compressor Centrifugal Blower	1.0*
Slight Torque Fluctuation	Screw Compressor Gear, Lobe and Vane Pumps Forced Draft Fan Medium Duty Mixer Lobe Blower	1.5
Substantial Torque Fluctuations	Reciprocating Pumps Heavy Duty Mixers Induced Draft Fans	2.0

*Use a minimum service factor of 1.25 on electric motor drives through a gearbox.

The examples given are for typical machines and are empirically based guidelines. Knowledge of actual torque characteristics may indicate a different service factor. Consult John Crane for advice.



A Windows® based computer selection program for the TSC is available. This selection program provides all necessary technical data, inertias, torsional stiffness, etc. Contact John Crane.

Available Options

- Spark-resistant couplings for hazardous zone operation.
- Special materials for low temperature applications and/or higher corrosion resistance.
- Electrical insulation.

- Torque limiting and shear pin designs.

Consult John Crane for any other special requirements. Metastream couplings can be adapted to suit virtually all power transmission coupling needs.



TSC

METASTREAM® T Series Couplings

Coupling Alignment

Correct installation and alignment of couplings is essential for reliable machinery performance.

John Crane supplies a variety of shaft alignment equipment and offers alignment training courses.

TSC MISALIGNMENT				
Coupling Size	Max. Axial Misalignment*		Max. Parallel Misalignment**	
	+/- in.	Equivalent Thrust-lb.	in.	Restoring Moment lb.-in.
0013	±0.040	47	0.020	36
0033	±0.050	63	0.020	54
0075	±0.060	81	0.022	78
0135	±0.080	126	0.024	104
0230	±0.100	166	0.040	130
0350	±0.110	175	0.040	300
0500	±0.130	243	0.040	360
0740	±0.150	286	0.048	420
0930	±0.170	331	0.055	480
1400	±0.200	608	0.060	540

NOTES: * Meets NEMA end float specifications without modification.

** Values based on angular deflection of 1/2° per end and minimum stock DBSE. Greater misalignment accommodation is possible by increasing dimension C.

The angular and axial restoring forces in the table below left are given at maximum deflections. The chart can be used to determine forces across the full deflection range. The nonlinear characteristics can detune a system to prevent high amplitude axial vibration.

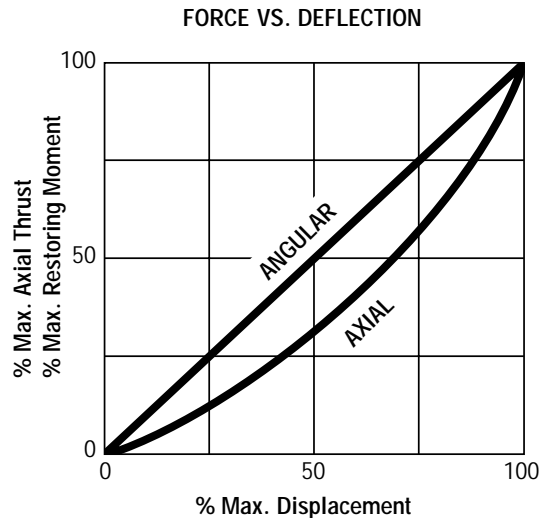

Balance Recommendations

The chart illustrates the relationship between the TSC sizes and their operating speeds to meet AGMA class 9, which is appropriate for most applications.

The inherent balance of the TSC range meets AGMA standard 9000-C90 class 9. Use this chart as a general guide to determine if dynamic balance improvement is required.

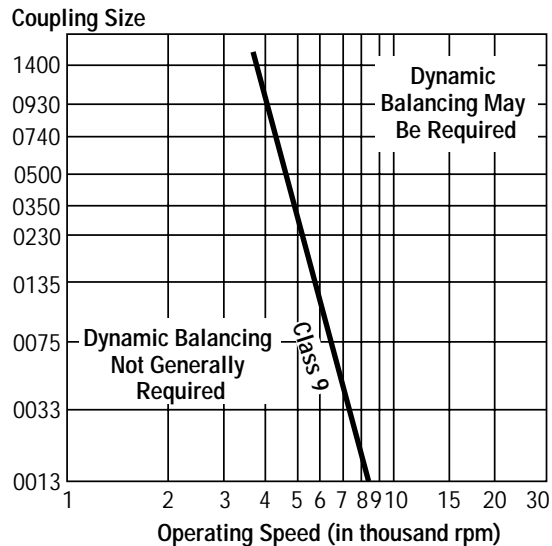

North and Latin Americas
Morton Grove, Illinois USA

Tel: 1-847-967-2400
Fax: 1-847-967-3915
1-800-SEALING

Europe, Middle East, Africa
Slough, UK

Tel: 44-1753-224000
Fax: 44-1753-224224

Asia Pacific
Singapore

Tel: 65-222-9161
Fax: 65-223-5035



For your nearest John Crane facility, please contact one of the locations above.

If the products featured will be used in a potentially dangerous and/or hazardous process, your John Crane representative should be consulted prior to their selection and use. In the interest of continuous development, John Crane Companies reserve the right to alter designs and specifications without prior notice.

2-7

Thrust Chamber Information

Schlumberger

REDA Production Systems

HORIZONTAL UNIT MAINTENANCE AND REPAIR

G3 THRUST SECTION

The thrust chamber reservoir is filled with the recommended lubricant prior to shipment. The fluid level will be at or near the center of the sight glass located on the side of the reservoir. As long as fluid is visible in the sight glass, it is not necessary to add oil.

MODEL G3 THRUST CHAMBER

A lubricant change is recommended every six months of continuous operation. A plug for draining the lubricant can be removed from the bottom of the reservoir. This plug is a 1" pipe plug and can be removed with an adjustable wrench. Fill the chamber through the vent cap located on top of the reservoir.

Caution should be taken not to fill the reservoir to a level above the center of the sight glass. The capacity is 1.0 gallon (3.79 liters). Do not overfill as overfilling causes excess heat build up in the thrust chamber.

It is not unusual to have a small amount of oil seepage from the front and rear seal of the bearing chamber. The leakage is minimal and replenishing of the oil level should not be required more than once in a six-month period.

Use only Reda recommended thrust chamber lubricant, Royal Purple, Synfilm 46 GT, Part Number 100179556 (five gallon).

Cartridge & Non-Cartridge Seal

The Cartridge type (or Non-Cartridge type) mechanical seal isolates the fluid from the thrust section. If this seal should leak, the fluid will be visible in the area between the intake and thrust section. When the seal requires changing out, the spacer coupling between the motor and the thrust chamber is removed. Any SS tubing connected to the seal cartridge needs to be removed (make sure the intake and discharge valves for the pump are closed and the pressure in the pump is bleed down). Provision should be made to prevent spillage of the oil. The thrust chamber and seal section is now ready to remove as a unit. The assembly must be supported during removal; the assembly weight is approx. 275 lbs. The ring of bolts on the seal-retaining bracket is removed. The assembly moves toward the motor until the "O"-ring has cleared. The assembly should move freely toward the motor. The thrust chamber shaft is coupled to pump shaft with a splined coupling. Inside the coupling is a set of shim washers. The shims are critical to the operation of the pump and must be installed when the unit is assembled. Once the assembly is moved back and the thrust chamber shaft has cleared the intake housing remove the splined coupling.

Cartridge Seal Removal

The seal and seal chamber is removed by first unscrewing four 7/16" Allen head bolts located on the fluid side of the adapter spool. The bolts are located on the same lip as the "O"-ring. The setscrews on the seal-driving sleeve are loosened. The shaft has to be cleaned of any foreign material. After the shaft is clean the seal and seal chamber is removed by use of two jacking bolts (use the 7/16 Allen head bolts). Once the seal chamber has cleared its mounting plate slide it down the shaft. The seal is removed from the seal chamber by removing the four bolts and separating the two pieces. The throat bushing located in the seal chamber should be inspected and replaced if damaged or worn.

Non-Cartridge Seal Removal

Thoroughly clean the shaft and primary ring surface area. Reverse the dismantle process to install the seal. O-Ring lubricant should be used when replacing the mating ring to facilitate installation. The use of tool Part Number 3900672 will also facilitate this installation. Use a quality non-detergent oil on the shaft to install the primary mating assembly.

All "O"-rings should be lubricated with silicon grease before assembly. The new seal is installed in the seal chamber and tighten. The rest of the components are assembled in the reverse order to disassembly.

Replacement of Thrust Chamber Bearing Sub-Assembly

The procedure for replacing the subassembly is basically the same as replacing the seal down to the point where the seal chamber is to be removed from the shaft. The eight bolts located at the junction of the bearing sub-assembly and the adapter spool are removed. This will separate the bearing sub-assembly and the adapter spool.

The new sub-assembly is attached to the adapter spool and then the seal chamber is installed as instructed above. Upon completion, it will be necessary to re-set or check the shaft setting. See Shaft Setting procedure.

Pump Replacement

The upper half of the pump clamps need to be loosened or removed the entire length of the skid. The base of the pump at the intake end is to be unbolted from the intake adapter. A section of the discharge piping, i.e., dropout spool, will have to be removed to allow the pump to be moved toward the discharge end of the skid 10 to 12 inches. The pump jacks need to be placed on the main beam accordingly to allow the entire pump to be lifted slightly by the jacks. Slide the pump away from the intake. If possible, leave the coupling between the intake and pump on the pump shaft. This coupling has been shimmed on the pump side. To avoid losing the shims, do not remove them from the coupling. The pump should be free. Using a two-point sling lift the pump out of the saddles and set aside. In the case of multiple pumps lift the pumps out in sections

starting with the pump farthest from the motor. Install the new pumps in the reverse manner shimming the pumps as described in the attached shimming procedure.

Since the top half of the pump support saddles have been removed from the skid, they must be replaced in the same manner as they were removed. The top and bottom half of each saddle has a number stenciled on one side only of each half. These numbers must match and be on the same side.

BOLTING TORQUE SPECIFICATIONS

- 3/8" bolts
- 1/2" heads
- 20 ft-lbs.
- If using a torque wrench (Part Number 1156926) with adapter (Part Number 0047225), set at 17 ft-lbs.

- 7/16" bolts
- 5/8" heads
- 30 ft-lbs.
- If using a torque wrench (Part Number 1156926) with adapter (Part Number 0047225), set at 26 ft-lbs.

- 1/2" bolts
- 3/4" heads
- 50 ft-lbs.
- If using a torque wrench (Part Number 1156926) with adapter (Part Number 0047233), set at 43 ft. lbs.

- 9/16" bolts
- 13/16" heads
- 70 ft-lbs.
- If using a torque wrench (Part Number 1156926) with adapter (Part Number 0047225), set at 61 ft-lbs.

- 5/8" bolts
- 15/16" heads
- 80 ft-lbs.
- If using a torque wrench (Part Number 1156926) with adapter (Part Number 0047225), set at 70 ft-lbs.

- 1" bolts
- 1 1/4" heads
- 100 ft-lbs.
- If using a torque wrench (Part Number 1156926) with adapter (Part Number 0047225), set at 87 ft-lbs.

Drawings and Bills of Materials

3.1	General Assembly Drawing and Bill of Materials _____	3-1
3.2	Thrust Chamber Serviceable Parts Drawing and Bill of Materials	3-1
3.3	Seal Drawing _____	3-1
3.4	Motor Drawing _____	3-1
3.5	Electrical Drawing _____	3-1
3.6	Pump Shaft Setting Procedure _____	3-1
3.7	Pump Drawing and Bill of Material _____	3-1

Intentionally Blank

PART NUMBER
HPS-120242

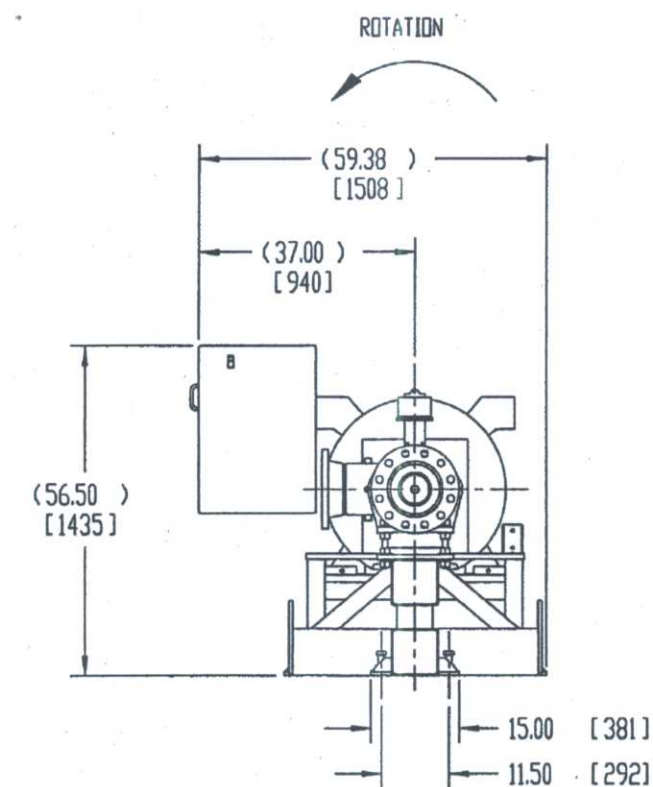
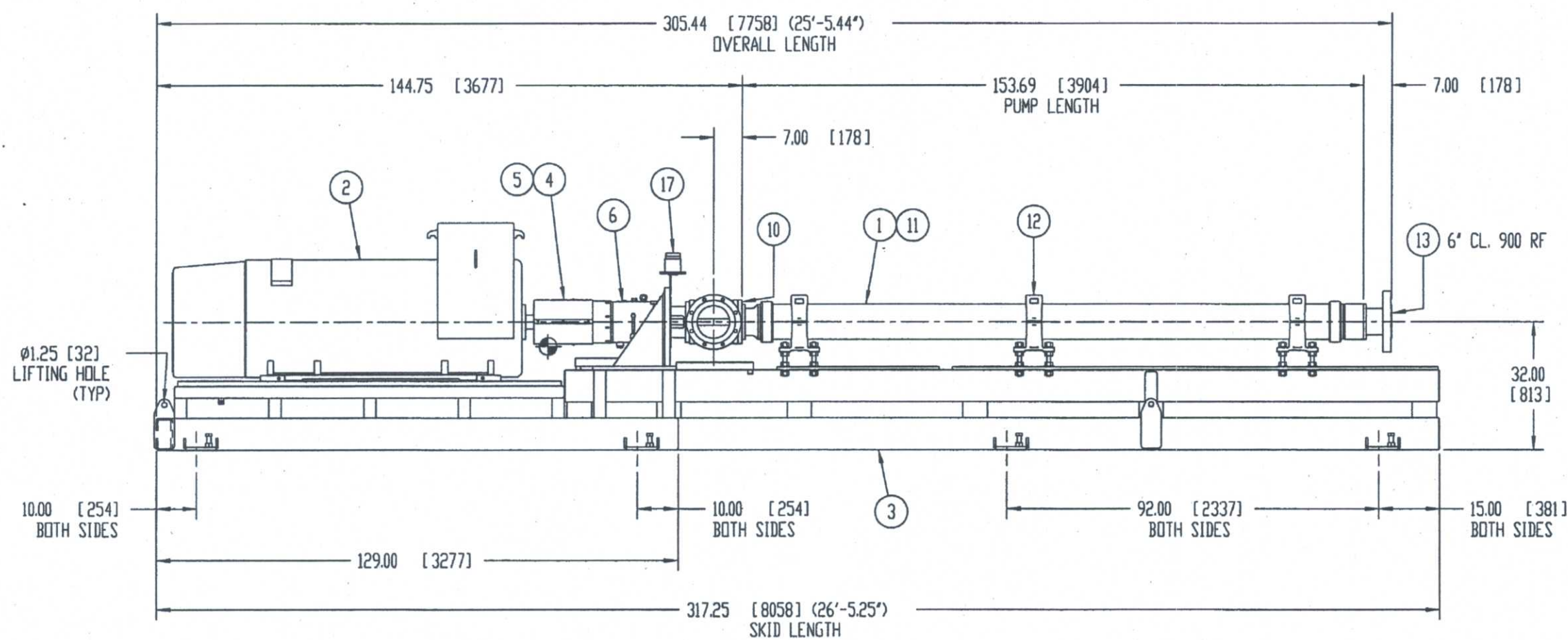
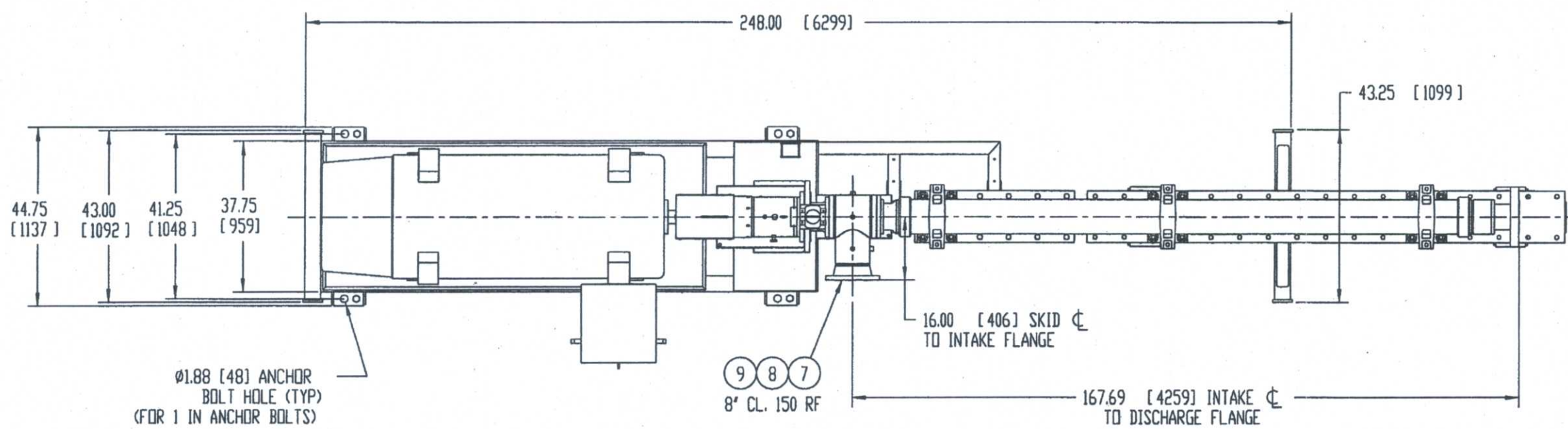

3. CENTER OF GRAVITY SYMBOL \oplus IS FOR REF ONLY AND LOCATED 26" VERTICALLY FROM MOUNTING SURFACE AND 97" HORIZONTALLY FROM MOTOR END.
2. DIMENSIONS IN () ARE IN MM
1. DIMENSIONS IN () ARE IN FT'-IN'

CUSTOMER: HUSKY ENERGY
 PROJECT: ALLIANCE OIL BATTERY DISPOSAL PUMP REPLACEMENT
 LOCATION: 04-16-040-12W4M
 PROJECT NO: 361700
 ESTIMATED UNIT WEIGHT: 16,000 LBS.
 APPLICATION: WATER INJECTION PUMP
 TAG NO: P-535
 PUMP SERIAL NO: 2SE9A52840

UNLESS OTHERWISE SPECIFIED
 DIMENSIONS ARE IN INCHES.

TOLERANCES:
 2 PLACE DECIMALS $\pm .01$
 3 PLACE DECIMALS $\pm .005$
 ANGLES $\pm 1/2^\circ$

REMOVE ALL BURRS AND BREAK ALL
 SHARP EDGES .015 MINIMUM.

CHECK FOR RELATED DOCUMENTS IN THE
 ENGINEERING SYSTEM.

DO NOT SCALE DRAWING

CONFIDENTIAL AND TRADE SECRET. DO NOT DISCLOSE, USE OR
 REPRODUCE WITHOUT WRITTEN APPROVAL FROM SCHLUMBERGER

Schlumberger BPC BARTLESVILLE, OK	DESIGNER HARKER	DATE 22-Dec-08
	DESIGN ENG. BLACK	DATE 22-Dec-08
TITLE DWG, GA: G3N13, HUSKY ENERGY, RFQ 120242		
DWG. NO. HPS-120242D	REV. AB	
SCALE 0.025	PROJECT REDA_HPS	SHT OF

DRAWING REVIEW

REVIEW IS FOR GENERAL COMPLIANCE WITH CONTRACT DOCUMENTS. NO RESPONSIBILITY IS ASSUMED FOR CORRECTNESS OF DESIGN (IF REQUIRED OF THE VENDOR/CONTRACTOR), DIMENSIONS OR DETAILS.

NO EXCEPTIONS TAKEN
 PROCEED WITH CONSTRUCTION
 MAKE CORRECTIONS NOTED
 PROCEED WITH CONSTRUCTION
 REVISE AND RESUBMIT

BY: *[Signature]* DATE: Jan 23, 2009
 PROJ. NO. 361700 DATE RECEIVED: JAN 22 2009

DRAWING CHECK

Preparation	Check	Initial	Date
DR	DR	DR	Jan 22, 2009
PN	PN	PN	Jan 22, 2009
MA	MA	MA	Jan 21, 2009
KB	KB	KB	Jan 21, 2009
DD	DD	DD	Jan 21, 2009
HT	HT	HT	Jan 21, 2009

RETURN TO: *[Signature]* DATE: JAN 29 2009

MASTER MARK-UP PRINT
 Tartan ENGINEERING DATE: JAN 22 2009

Part SLB HPS-120242 AA: Engineering Bill of Materials

Usage	Type	Name	Rev	Last Rev	Description	State	U of M	Qty	Item Num	Reference Designator	General Notes
Uses	Part SLB	100444173	AA	AA	PUMP: M675-A C-CT 19 STG 862/862 19 CS BTHD, 1.37 INC 718, M-TRM, HSN, ARZ, SS H&B, HPS, BLUE PAINT	Released	EA	1.0	001		
Uses	Part SLB	100624994	AA	AA	MOTOR: SIEMENS, 700HP 480V 716A 60HZ, 5812SY, TEFC, SLEEVE BRG, BEARING/WINDING RTDS, OVERSIZED J-BOX, <i>Vibration Switch</i>	Released	EA	1.0	002		
Uses	Part SLB	100625183	AA	AA	WELDMNT ASSY, G3, ND, 3 CLAMP, 14.5 INCH HEIGHT, SIEMENS 5812SY MOTOR	Released	EA	1.0	003		
Uses	Part SLB	100365509	AA	AA	ASSEMBLY: COUPLING, METASTREAM, TSCS/TSKS 0350, W/ 7.0 IN SPACER, 3.375-2.375 BORES	Released	EA	1.0	004		
Uses	Part SLB	100480871	AC	AC	GUARD: ASSY, HPS, CPLG, 16-22 INCHES	Released	EA	1.0	005		
Uses	Part SLB	100448445	AG	AG	THRUST CHAMBER: ASSEMBLY, 1 BEARING, HPS, G3A, 1.50-6B SPLINE, STD BLUE	Released	EA	1.0	006		
Uses	Part SLB	7005564	-0	-0	SEAL: JC, TYPE 2, 1.50 SZ, NON-CART, MONEL, HSN, CF-SP-93410-8	Released	EA	1.0	007		
Uses	Part SLB	100538851	AB	AB	SEAL HOUSING: ASSY, G3, NON-CART, TYPE 2 SEAL, W/FLANGE O-RING	Released	EA	1.0	008		
Uses	Part SLB	3909512	AE	AE	ASSEMBLY: INTAKE, 8 IN, 150, RFWN, 316L SS, G2, MAWP-230 PSI	Released	EA	1.0	009		
Uses	Part SLB	3909572	AE	AE	ADAPTER:INTAKE,PMP 862/950,SS,12 HOLES	Released	EA	1.0	010		
Uses	Part SLB	3906175	-D	-D	COUPLING: ASSY, 1.50-6B X 1.375-6B SPLINE, 3.77 IN., MONEL	Released	EA	1.0	011		
Uses	Part SLB	100330567	AA	AA	CLAMP: PUMP, HPS, 862 SERIES PUMP, STD GRAY	Released	EA	3.0	012		
Uses	Part SLB	3909102	-D	-D	HEAD ASSY: DISCHARGE, 6 IN., 900, RF, 862 SERIES, 316L SS, MAWP-1800 PSI	Released	EA	1.0	013		
Uses	Part	100335857	AK	AK	KIT: SWITCH, VIBRATION, MURPHY VS2EX	Released	EA	1.0	017		

DRAWING REVIEW

REVIEW IS FOR GENERAL COMPLIANCE WITH CONTRACT DOCUMENTS. NO RESPONSIBILITY IS ASSUMED FOR CORRECTNESS OF DESIGN (IF REQUIRED OF THE VENDOR/CONTRACTOR), DIMENSIONS OR DETAILS.

NO EXCEPTIONS TAKEN PROCEED WITH CONSTRUCTION
 MAKE CORRECTIONS NOTED PROCEED WITH CONSTRUCTION
 REVISE AND RESUBMIT

BY: *[Signature]* DATE: *Jan 23, 2009*
 PROJ. NO. *301700* DATE RECEIVED: **JAN 22 2009**



DRAWING CHECK

Department	Circulate to	Initial	Date Released	Date Checked
Design	DR			
Process	PN	<i>PN</i>	<i>Jan 22/09</i>	<i>Jan 22/09</i>
Mechanical	MA	<i>mi</i>	<i>22/01</i>	<i>22/01</i>
Instrument	KB	<i>[Signature]</i>	<i>23/01/09</i>	
Systems	DD	<i>[Signature]</i>	<i>2008-2009</i>	
Structure				
Operations				
Project Engineer				
Project Manager	<i>HT</i>	<i>[Signature]</i>	<i>Jan 23/09</i>	

RETURN TO *HT* BY **JAN 29 2009**

MASTER MARK-UP PRINT
 DATE: **JAN 22 2009**

SLB											
Uses	Part	Name	Rev	Last Rev	Description	State	U of M	Qty	Item Num	Reference Designator	General Notes
	100102422	AJ	AJ		CP: HPS-G3, 3 CLAMP, CLASS 600 INTAKE, COMPONENT HARDWARE DETAILS	Released	EA	1.0	020		
	100155124	AB	AB		KIT, MOTOR MOUNTING, 1.000 BOLTS	Released	EA	1.0	022		
	100164429	AA	AA		KIT, HPS, O-RING SET, HSN, 862 SERIES	Released	EA	1.0	023		
	100278072	AA	AA		KIT, DISCHARGE MOUNTING, 862 SERIES PUMP, MONEL	Released	EA	1.0	024		



DRAWING REVIEW

REVIEW IS FOR GENERAL COMPLIANCE WITH CONTRACT DOCUMENTS. NO RESPONSIBILITY IS ASSUMED FOR CORRECTNESS OF DESIGN (IF REQUIRED OF THE VENDOR/CONTRACTOR), DIMENSIONS OR DETAILS.

NO EXCEPTIONS TAKEN. PROCEED WITH CONSTRUCTION.
 MAKE CORRECTIONS NOTED. PROCEED WITH CONSTRUCTION.
 REVISE AND RESUBMIT.

BY: [Signature] DATE: Jan 23, 2009
 PROJ. NO. 3101700 DATE RECEIVED: JAN 22 2009



DRAWING CHECK

Department	Circulate to	Initial	Date Received	Date Checked
Process & Design	DR			
Process	PN	[Initials]	Jan 22/09	Jan 22/09
Mechanical	MA	[Initials]	22/01	22/01
Instrument	KB	[Initials]	23/01/09	
Systems				
Electrical	DD			
Civil & Structural				
Operations				
Project Engineer				
Project Manager	HT		Jan 23/09	

RETURN TO: HT BY: [Signature] DATE: JAN 29 2009

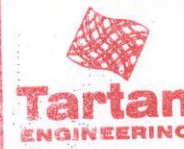

MASTER MARK-UP PRINT

DATE: JAN 22 2009

3/3

4

3

2

1

PART NUMBER	SHAFT MAT'L
100448445	SS
100478132	INC 625

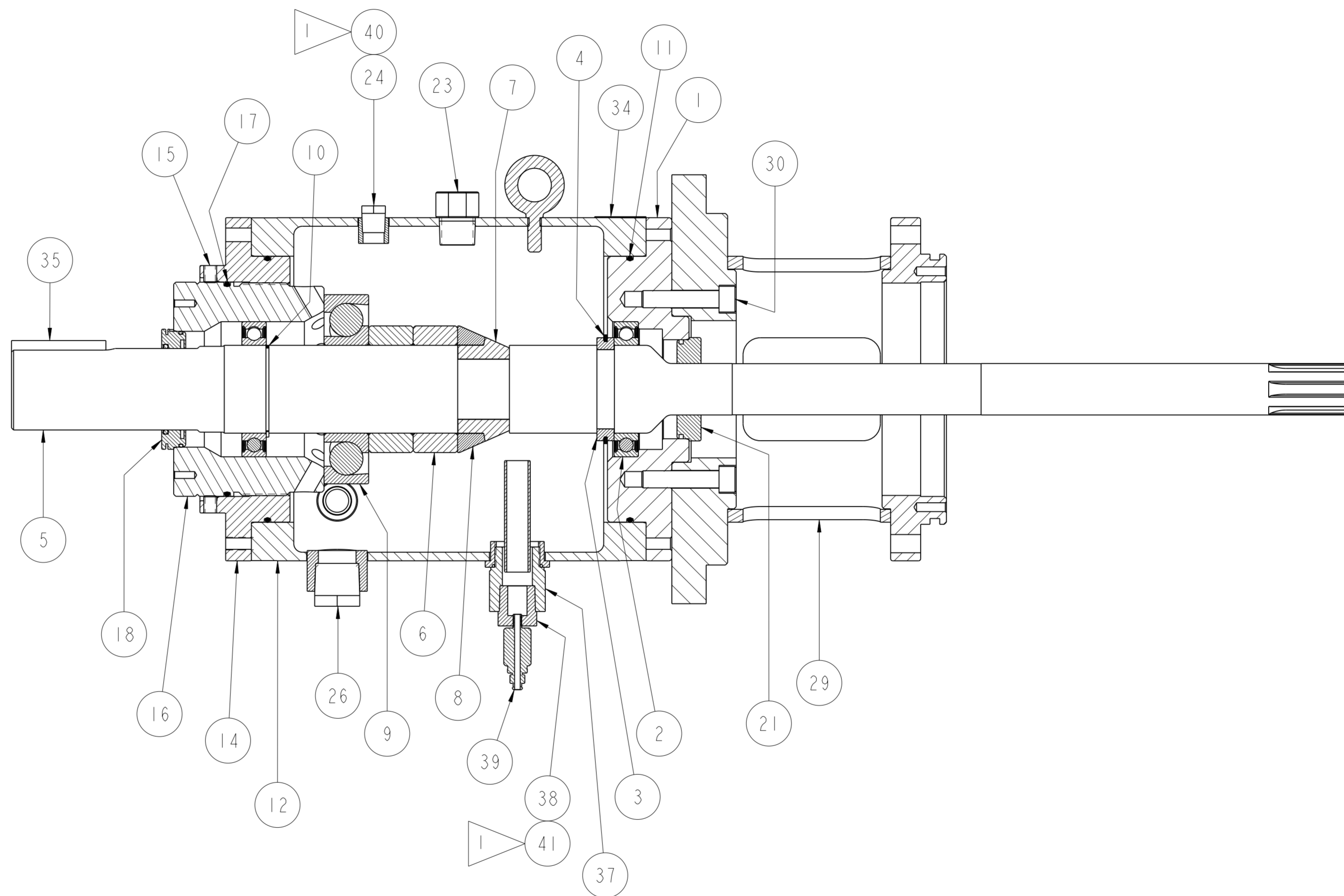
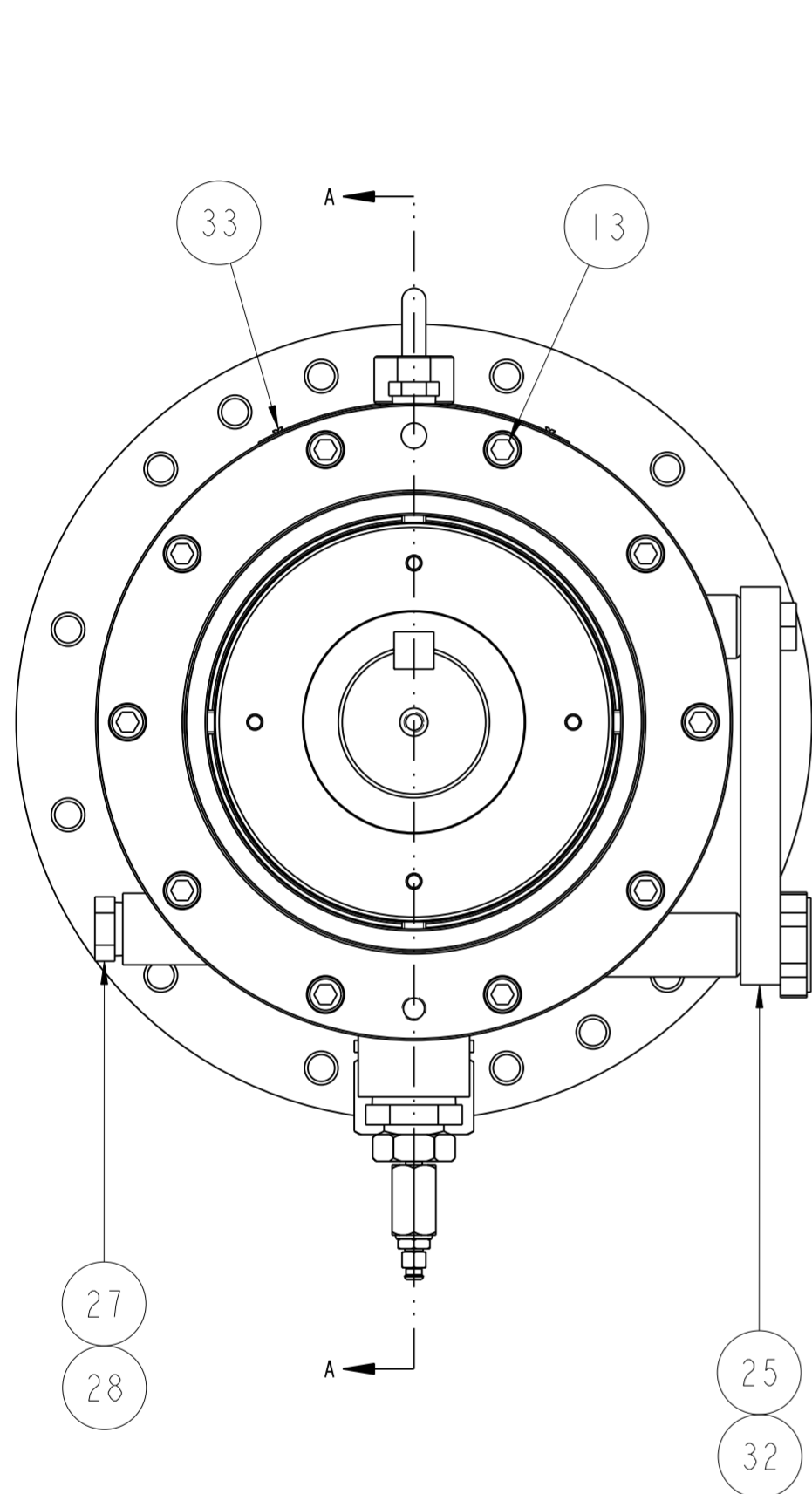

USE FOR STORING AND SHIPPING ONLY.

<p>UNLESS OTHERWISE SPECIFIED DIMENSIONS ARE IN INCHES.</p> <p>TOLERANCES: 2 PLACE DECIMALS ± .01 3 PLACE DECIMALS ± .005 ANGLES ± 1/2°</p> <p>REMOVE ALL BURRS AND BREAK ALL SHARP EDGES .015 MINIMUM.</p> <p>CHECK FOR RELATED DOCUMENTS IN THE ENGINEERING SYSTEM.</p> <p>DO NOT SCALE DRAWING</p> <p>CONFIDENTIAL AND TRADE SECRET. DO NOT DISCLOSE, USE OR REPRODUCE WITHOUT WRITTEN APPROVAL FROM SCHLUMBERGER</p>	<p>Schlumberger BPC BARTLESVILLE, OK</p>	<p>DESIGNER HARKER</p> <p>DESIGN ENG. BLACK</p>	<p>MATERIAL</p> <p>DATE 02-Jul-07</p> <p>DATE 02-Jul-07</p>
	<p>TITLE DWG, THRUST CHAMBER: ASSEMBLY, 1 BEARING, HPS, G3A, 150-6B SPLINE</p>		
	<p>DWG. NO. 100448445D</p>	<p>SCALE 0.111</p>	<p>PROJECT REDA HPS</p>

4

3

2

1

Part SLB 100448445 AG: Specifications and Engineering Bill of Materials

Robert D Brandabura 166794
Oct 24, 2008

												EBOM Values		Specification Values	
Type	Name	Rev	Last Rev	Description	State	U of M	Qty	Item Num	General Notes	Relationship Name	Reference Designator	Usage	Document Usage	Files	
Document	100516236	AC	AC	MPI-56137, HPS - G3A THRUST CHAMBER ASSEMBLY PROCEDURE	Released		0.0			Part Specification			Reference Document	100516236.doc 100516236.pdf	
ProE Drawing	100448445D	AC	AC	DWG. THRUST CHAMBER: ASSEMBLY, 1 BEARING, HPS, G3A, 1.50-6B SPLINE	Released		0.0			Part Specification			Described By	100448445d.drw.2 100448445d_1.dxf 100448445D.ps 100448445D.pdf	
Instruction-Procedure	100098119	AG	AG	MPI-56116, STANDARD PAINT PROCEDURE - HPS EQUIPMENT	Released		0.0			Part Specification			Reference Document	100098119.MPI-56116.doc 100098119.MPI-56116.rsg.doc 100098119.MPI-56116.pdf 100098119.MPI-56116.rsg.pdf	
General Spec	GED-001	BM	BM	EQUIPMENT SERIAL NUMBERING SYSTEM	Released		0.0			Part Specification			Reference Document	GED-001.DOC GED-001.pdf	
Part SLB	100478795	AA	AB	BUSHING: REDUCER, 3/8 NPT(M) X 1/4 NPT(F), .316 SS, SAE 140140, PARKER# 3/8 X 1/4 PTR-SS OR EQUIV	Released	EA	1.0	040	For storing and shipping only	EBOM		Uses			
Part SLB	3920326	AA	AB	OIL: LUBE, TC, 5 GAL PAIL, ROYAL PURPLE, SYNFILM #46	Released	GA	0.75	031		EBOM		Uses			
Part SLB	100148881	AA	AA	SPOOL, BEARING HOUSING, MACHINING, G3	Released	EA	1.0	029		EBOM		Uses			
Part	100082461	AA	AA	SPACER: THRUST BEARING, 2.561 X 1.296L, 4140, G3	Released	EA	2.0	006		EBOM		Uses			
Part SLB	3920149	-C	-C	SCREW: SHC, 1/2-20 UNF X 2-1/4 IN. LG. UNBRAKO ALLOY STEEL, 170 K MIN. YIELD, HIGH ST	Released	EA	8.0	030		EBOM		Uses			
Part SLB	3908811	-D	-D	GAUGE: LEVEL, FLUID, 0-220F, VENDOR PN G615-05-A3	Released	EA	1.0	025		EBOM		Uses			
Part SLB	100448339	AA	AA	FITTING: PIPE, REDUCER, 1 IN MNPT X .25 FNPT, VENDOR #1 X 1/4 PTR	Released	EA	1.0	038		EBOM		Uses			
Part SLB	3900388	-D	-D	PLUG: DRAIN, 3/8 IN. NPT, HEX HEAD	Released	EA	1.0	024		EBOM		Uses			
Part SLB	3900434	-D	-D	RING: SNAP, #N5100-255 OR EQUAL	Released	EA	1.0	010		EBOM		Uses			
Part SLB	0866582	-D	-D	RING, O: 2-25B, VITON, V884-75	Released	EA	1.0	017		EBOM		Uses			
Part SLB	0014982	AB	AB	RING: RETAINER, TRUARC #5100-300	Released	EA	1.0	004		EBOM		Uses			
Type	Name	Rev	Last Rev	Description	State	U of M	Qty	Item Num	General Notes	Relationship Name	Reference Designator	Usage	Document Usage	Files	
Part SLB	100448300	AA	AA	ADAPTER: BLEED, PIPE, MALE, VENDOR PN 1/4HPBA	Released	EA	1.0	039		EBOM		Uses			
Part SLB	100479718	AA	AA	ASSEMBLY: STAND TUBE, G3A, TC	Released	EA	1.0	037		EBOM		Uses			
Part	100082463	AA	AA	RING: TWO PIECE RETAINER, G3 TC	Released	EA	1.0	003		EBOM		Uses			
Part SLB	100390497	AA	AA	SEAL: BRG ISOLATOR, PMP END, 1.50, HPS, G3 TC, INPRO #TN09633	Released	EA	1.0	021		EBOM		Uses			
Part	100090972	AA	AA	RING, 2 PIECE, RETAINER, G3 TC	Released	EA	1.0	007		EBOM		Uses			
Part	100094390	AD	AD	SHAFT: THRUST CHAMBER, HPS, G3 TC, 1.50, STANDARD	Released	EA	1.0	005		EBOM		Uses			
Part SLB	100307054	AC	AC	BEARING: NSK, DEEP GROOVE BALL, 6013ZC3E EA2S, SINGLE ROW, CONRAD STYLE, DOUBLE SHIELDS, C3 CLEARANCE, SYNTHETIC GREASE	Released	EA	2.0	002		EBOM		Uses			
Part SLB	100188102	AB	AB	KEY: THRUST CHAMBER, SHAFT, G3, .625 IN. X .585 IN. X 2.75 IN. LG.	Released	EA	1.0	035		EBOM		Uses			
Part	100084422	AB	AB	PUMP END HOUSING, G3 TC	Released	EA	1.0	001		EBOM		Uses			
Part SLB	0825901	-E	-E	SCREW: DRIVE, #2 X 1/8 316SS, TYPE U ANSI/ASME	Released	EA	2.0	033		EBOM		Uses			

				B18.6.4,1981														
Part SLB	3902629	-B	-B	PAINT:AMERON,SLB BLUE,PSX700,W/CATALYST	Released	GA	0.25	036			EBOM		Uses					
	Part SLB	100478798	AA	AB	FITTING: ADAPTER, 3/8 FNPT X 1/4 MNPT, PARKER #3/8 X 1/4 FG-SS (or equivalent), SAE 140139	Released	EA	1.0	041	For storing and shipping only	EBOM		Uses					
Part SLB	100236108	AA	AA	LABEL: OIL LEVEL, THRUST CHAMBER, HPS, G3	Released	EA	1.0	032			EBOM		Uses					
Part SLB	100447640	AB	AB	SEAL: BRG ISOLATOR, 2.375, HPS, G3 TC, INPRO TN	Released	EA	1.0	018			EBOM		Uses					
Part SLB	100307037	AC	AC	BEARING:NSK, ANGULAR CONTACT BALL BEARING, 7313BEAMRSUNP6, SINGLE ROW, 40 DEGREE CONTACT ANGLE, MACHINED BRASS CAGE	Released	EA	1.0	009			EBOM		Uses					

	Type	Name	Rev	Last Rev	Description	State	U of M	Qty	Item Num	General Notes	Relationship Name	Reference Designator	Usage	Document Usage	Files	
	Part SLB	100420417	AA	AA	HOUSING: TC ASSM, FINAL MACHINE, WITH GAUGE, G3 TC	Released	EA	1.0	012		EBOM		Uses			
	Part	100090755	AC	AC	PLUG: DRAIN, MAGNETIC, HEX, 1 INCH, HPS, G3 TC	Released	EA	1.0	026		EBOM		Uses			
	Part	100084414	AA	AA	BREATHER: VENT PLUG, G3 TC	Released	EA	1.0	023		EBOM		Uses			
	Part	100084421	AB	AB	MOTOR END HOUSING, G3 TC	Released	EA	1.0	014		EBOM		Uses			
	Part SLB	3900618	-C	-C	PLUG:PIPE,1/2 IN. NPT,SQUARE HEAD,FORGED STEEL,PLATED	Released	EA	1.0	027		EBOM		Uses			
	Part SLB	100115650	AA	AA	RING, O: VITON 2-264 PARCO CMPD 9009-75	Released	EA	2.0	011		EBOM		Uses			
	Part SLB	3920078	-C	-C	SCREW:SHC,3/8-24 X 1-1/4 IN. LG.,UNBRAKO,ALLOY STEEL,170 K MIN. YIELD,HIGH STREN	Released	EA	20.0	013		EBOM		Uses			
	Part SLB	100461781	AB	AB	RING: RETAINER, THRUST BEARING, G3 TC	Released	EA	1.0	008		EBOM		Uses			
	Part SLB	3908703	-D	-D	NAMEPLATE: HPS THRUST CHAMBER, BLANK, STAINLESS STEEL	Released	EA	1.0	034		EBOM		Uses			
	Part SLB	0826339	-B	-B	SCREW, SET, 3/8-16UNC-3 X 1/2 HEX SCKT CUP POINT 410 STAINLESS ANSI/ASME B18.3.	Released	EA	4.0	015		EBOM		Uses			
	Part	100420623	AA	AA	COLLAR: THRUST, HPS G3 TC, INPRO SEALS	Released	EA	1.0	016		EBOM		Uses			

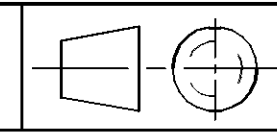

ITEM NO.	COMPONENT	DESCRIPTION	MATERIAL	SPARES QTY
1	D 1500 902 9221	MATING RING	SILICON CARBIDE	1 X
2	0000 225 5543	O-RING	BUNA(HSN)	1 X
3	D 1501 270 9221	PRIMARY RING	SILICON CARBIDE	1 X
4	D 1500 278 3848	BELLOWS	BUNA(HSN) (NOTE 30)	1 X
5	D 1500 086 1800	RETAINER ASSEMBLY	MONEL	1
6	1546	SPRING	MONEL	1
7	D 1500 725 1800	DISC	MONEL	1
8	D 1501 497 1800	SPRING HOLDER	MONEL	1
9				
10				
11				
12				
13				
14				
15				
16				
17				
18				
19				
20				
21				
22				
23				
24				
25				
26				
27				
28				
29				
30				
31				
32				
33				
34				
35				

DO NOT TREAT BELLOWS *****

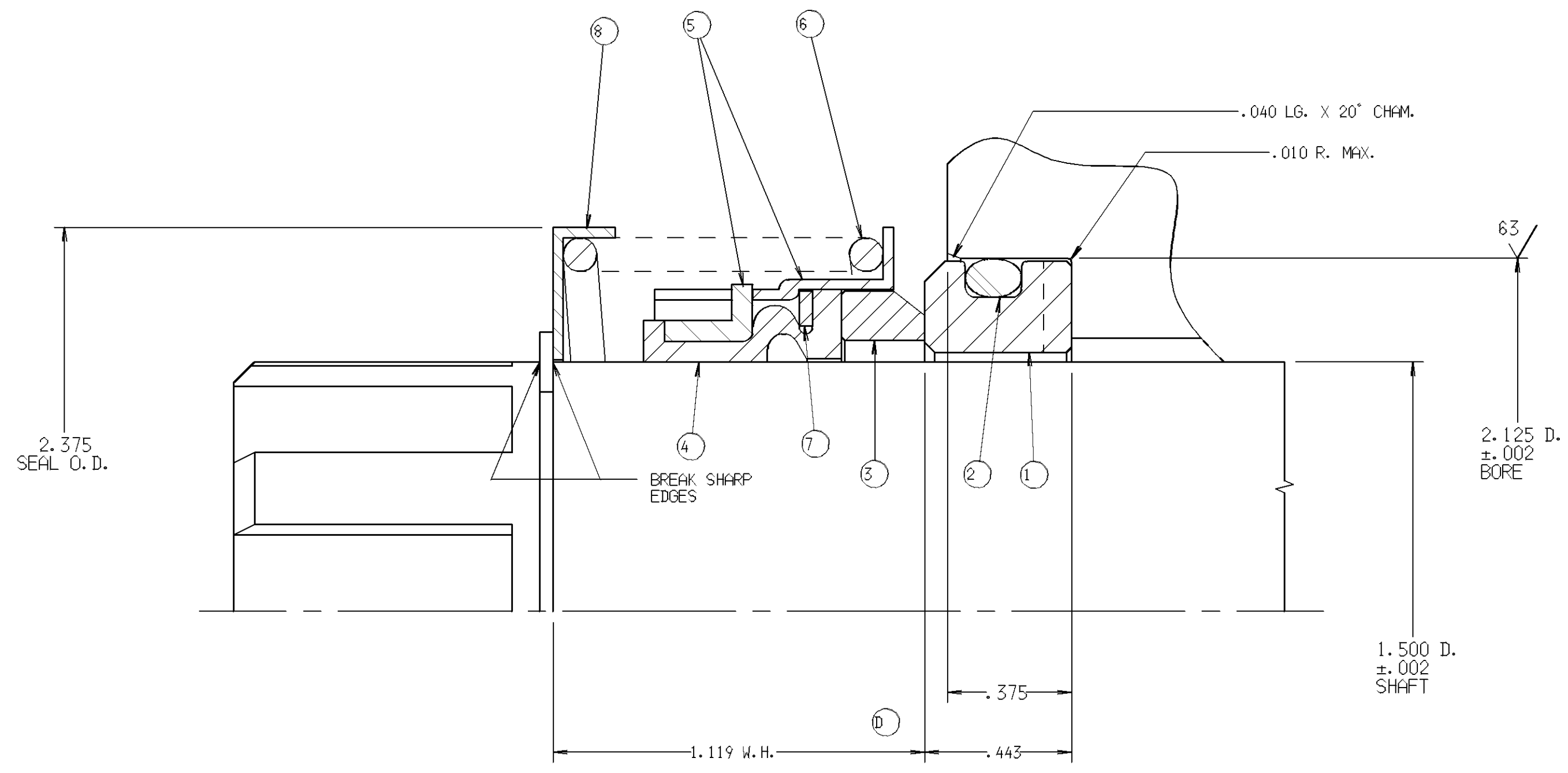

NOTE:
 ITEM #3 IS MATTE FINISH.

 RETAINER ASS'Y. CONSISTS OF:
 RETAINER D-1501-204
 DRIVE BAND D-1500-088
 REDA PROTECTOR WITH 1-1/2" D. SHAFT

SEAL ASS'Y NO. D-1501-237	BILL OF MATERIALS NUMBER		
MTG. RG. ASS'Y NO.	COMPLETE		
	SEAL HD.		
	MTG. RG.		
	ASS'Y.	ITEMS	NUMBER
EQUIPMENT REFERENCE:		CUSTOMER INFORMATION:	
UNIT BY: REDA PUMP	CUSTOMER: REDA HPS		
EQUIPMENT TYPE:	P. O. NO.		
<input checked="" type="checkbox"/> PUMP <input type="checkbox"/> AGITATOR	END USER: REDA HPS		
<input type="checkbox"/> COMPRESSOR <input type="checkbox"/> OTHER	LOCATION: OWASSO, OK.		
MODEL/SIZE	REQ. NO.		
SERIAL NO.	INSTALLED AT:		

WARRANTY APPLIES TO DIMENSIONAL DATA ONLY

SEAL DATA						
SEAL DESCRIPTION A021	MATERIAL CODE B97 058 M 058 M					
A. P. I. CODE	A. P. I. PLAN N/A					
SERVICE DATA						
FLUID N/A	SUCT. PRESS. N/A		BARRIER FLUID N/A			
SEAL PRESS. N/A	DISCH. PRESS. N/A		VISC. AT P. T. N/A			
TEMPERATURE N/A	SP. GR. N/A		V. P. AT P. T. N/A			
SHAFT SPEED N/A	HAZARD CODE N/A					
REFERENCE DATA	DRAWN	DATE	CHK'D	APP'D	SCALE	INST CODE
DATA PER RON DAVIS ENG. PROJ. #:98-0938	BCL	101698	JMA	SAS	3=1	

30. ITEM #4 WILL HAVE TWO (2) WHITE COLOR CODED MARKS.
 NO SUBSTITUTION ALLOWED FOR ITEMS #2 & #4.

THE FOLLOWING NOTES ARE IMPORTANT AND MUST BE OBSERVED FOR CORRECT SEAL INSTALLATION AND OPERATION

- REMOVE ALL SHARP EDGES ON SHAFT &/OR SLEEVE BEFORE INSTALLATION OF SEAL
- SURFACE OF SHAFT OR SLEEVE ON WHICH SEAL IS INSTALLED MUST BE MACHINED TO 63 RA FINISH OR BETTER.
- LUBRICATE SHAFT/SLEEVE & SEAL WEDGE RING/O-RING/BELLOWS TO ASSIST INSTALLATION OF SEAL WITH
- LUBRICATE MATING RING (SEAT), SEALING MEMBER & HOUSING TO ASSIST INSTALLATION.
- MUST BE CIRCULATED AROUND PRIMARY RING (SEAL FACE)/THROUGH MATING RING (SEAT) (AT NOT LESS THAN) IN ORDER TO REMOVE HEAT GENERATED, OR FAILURE MAY OCCUR.
- WHEN SHAFT IS SLEEVED THROUGH STUFFING BOX, SLEEVE MUST BE LIQUID TIGHT THROUGH BORE.
- SHAFT OR SLEEVE MUST BE OF CORROSION RESISTANT MATERIAL WITH A HARDNESS OF 125 BRINELL MINIMUM & BE MACHINED TO DIMENSIONS & TOLERANCES STATED.
- END OF SEAL CHAMBER & AXIS OF SHAFT MUST BE AT 90° TO EACH OTHER WITHIN .002 F. I. M.
- BEFORE COMPLETING SEAL INSTALLATION WIPE LAPPED SURFACES OF MATING RING (SEAT) & PRIMARY RING (SEAL FACE) PERFECTLY CLEAN.

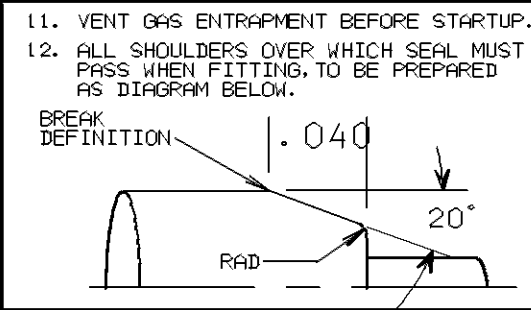

CAD ENGINEERED	TULSA # 65	CAT	DRAWING No. CF-SP-93410-8	ISSUE A
SEAL SIZE: Ø 1.500		SEAL TYPE: T-2		

John Crane
 JOHN CRANE INC.
 International Sealing Systems
 6400 Oakton Street
 Morton Grove, IL 60053, U. S. A.

3-5
Electrical Drawing

Not Applicable on this order

3-6
Pump Shaft Setting
Procedure

HPS 862 –H SERIES SHAFT SETTING PROCEDURE

ALL HORIZONTAL CONFIGURED “M” TYPE PUMPS, 862 SERIES, ARE BUILT WITH COMPRESSION THRUST DESIGN. THIS DESIGN REQUIRES THE SHAFT TO BE SPACED CORRECTLY TO THE THRUST CHAMBER IN ORDER TO PROPERLY TRANSFER PUMP THRUST. IF THE UNIT IS A TANDEM, EACH PUMP-TO-PUMP SHAFT MUST ALSO BE PROPERLY SPACED TO EACH OTHER.

INSTALLATION/ SPACING TOOL, SHIMS, AND INSTRUCTIONS:

SHAFT SPACING INSTRUCTIONS FOR DOWNHOLE PUMPS NORMALLY USE SHAFT “LIFT”, “MATCH” AND “DROP” AS SHAFT POSITIONING FROM A PUMP VERTICAL, SHAFT FULL DOWN REFERENCE. “LIFT” WILL ALSO BE USED IN THIS DOCUMENT TO DESIGNATE SHAFT POSITIONING FROM A PUMP HORIZONTAL, WITH SHAFT “FULL-DOWN”, TOWARD THE BASE.

1.161 DIAMETER MONEL SHIMS:

- 1/64” P/N 1146521
- 1/32” P/N 1146539
- 1/16” P/N 1146547

“H” TOOL:

- 862 TO THRUST CHAMBER, AND 862 PUMP-TO-PUMP P/N 354597

*Note: The bolt pattern on the 862 -H fits the 950 H-Tool

1. WITH PUMP OUT OF THE WAY FORWARD, COUPLING IN PLACE ON THRUST CHAMBER SHAFT, BOLT “H” TOOL #354597 ONTO THE THRUST CHAMBER FLANGE AS SHOWN IN FIGURE “1”. LOOSEN JAM NUT (4) AND TURN BOLT (5) DOWN UNTIL IT BOTTOMS ON THE COUPLING DIVIDER PLATE. TIGHTEN BOLT (SNUG ONLY) THEN TIGHTEN JAM NUT.
2. REMOVE TOOL FROM THRUST FLANGE, AND BOLT IT ONTO THE PUMP BASE FLANGE, AS SHOWN IN FIGURE “2”.
3. FROM PUMP HEAD END, PUSH ALL SHAFT PLAY DOWN, TOWARD THE BASE, TO OBTAIN A “FULL-DOWN” SHAFT POSITIONING.
4. SELECT APPROPRIATE SHIM(S) NECESSARY TO FILL OPEN SPACE “A” BETWEEN PUMP SHAFT AND BOLT HEAD (4) FIGURE “2”. (*TAKE PRECAUTIONS NOT TO INADVERTENTLY MOVE SHAFT!*)
5. AFTER SHIM STACK IS DETERMINED, ADD AN ADDITIONAL 1/32” SHIM, GREASE AND PLACE THEM INTO THE COUPLING.
6. REMOVE TOOL, AND BOLT PUMP TO THRUST CHAMBER.

IF THE INSTALLATION IS NOT TANDEM, SHAFT SPACING IS COMPLETED.

IF THE INSTALLATION INCLUDES TANDEM, THE OTHER PUMP SECTIONS MUST HAVE THEIR SHAFTS SPACED, (PUMP-TO-PUMP), IN THE SAME MANNER AS THE FIRST SECTION.

(EACH SECTION OF 862 SERIES PUMP REQUIRES A SHAFT LIFT OF 1/16” FROM THE “FULL-DOWN” POSITION.)

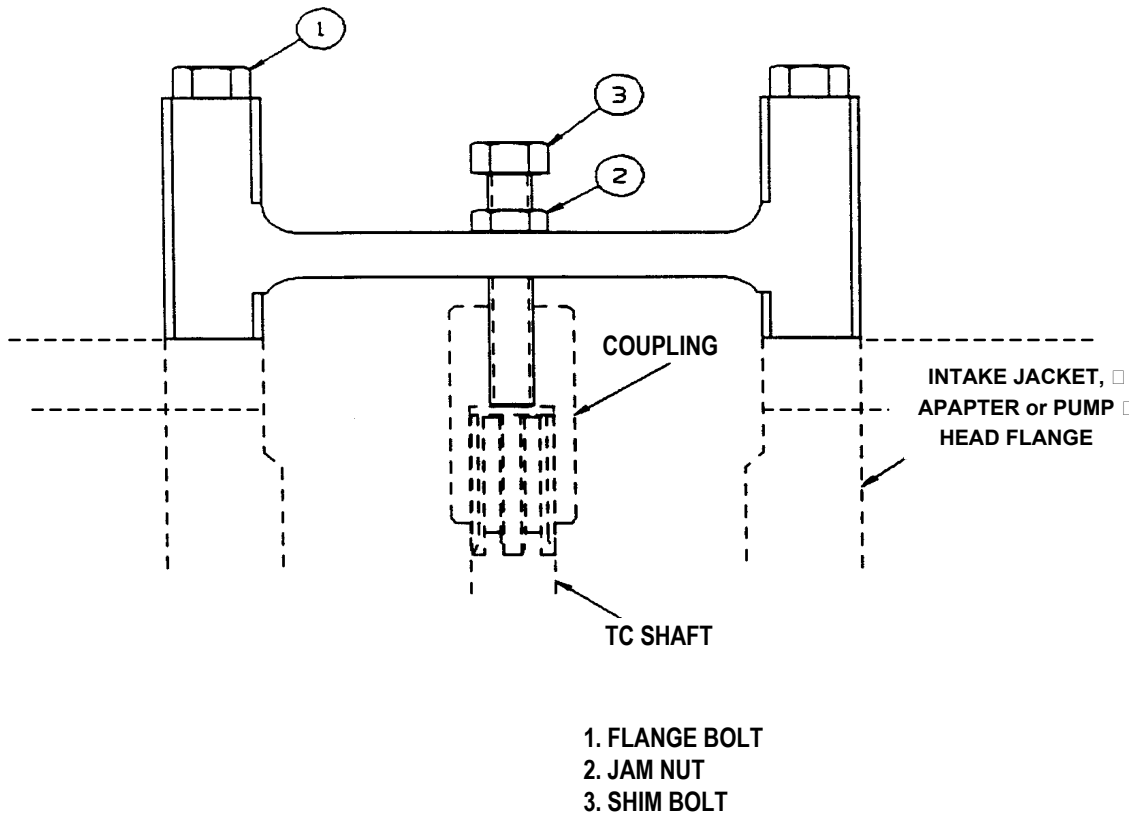

Figure 1: Shaft setting tool on Intake Jacket, Adapter or Pump Head

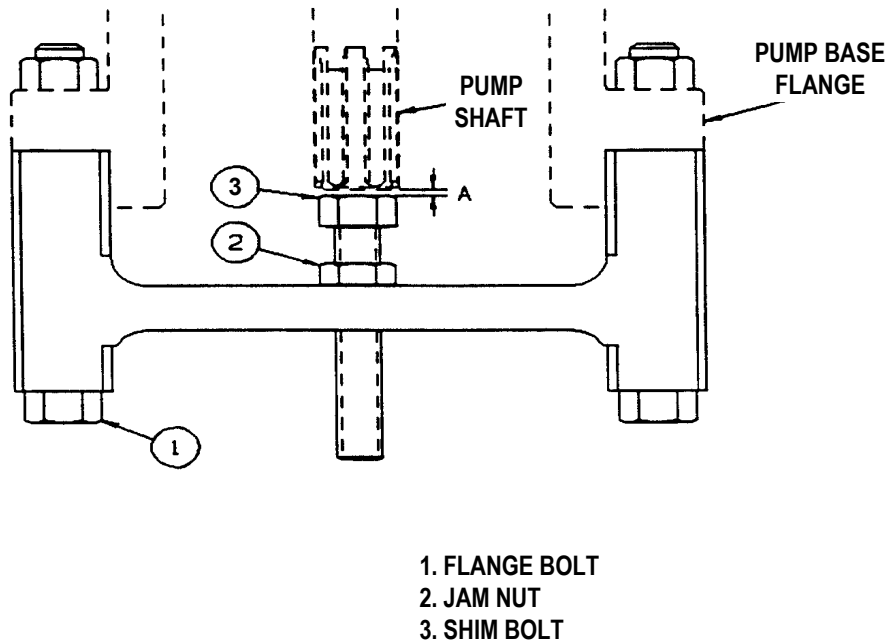

Figure 2: Shaft setting tool on Pump Base Flange

Pump Performance Tests and Reports

4.1	Pump Test Results and Hydro Test Certs _____	4-1
4.2	Hydrostatic Test Certs (Intake and Discharge) _____	4-1

Schlumberger Artificial Lift - Nisku Service Center
HORIZONTAL PUMP TEST RESULT

04/02/2009 10:23:2

Working Pressure : 0	Hydrostatic Test Pressure: 0
Work Order Number : BFP52840	Part Number : 10044173
Log Number : NISP12009020402	Well Site : 4-16-40-12W4
Pump Serial Number : 2SE9A52840	Thrust Type : C
Stage Type : M675A	Bearing Type : ARZ
Number of Stages : 19	Pump Config : CT
Max Recommended Flow: 33150	BEP Flow : 26396
Curve RPM : 3570	Min Recommended Flow : 19380
Avg Water Temperature : 39	Torque Factor : 1.97
PumpStart : 04/02/2009 10:07:36 AM	Test Category : New
	Pump Stop : 04/02/2009 10:15:33 AM
Customer : HUSKY	Operator Number : SDH/RS
Comments : 19HSG	

---values are corrected to 3570 RPM---

	BPD	INLET PSI	OUTLET PSI	TORQUE RAW	PUMP RPM	EFF	BPD	HEAD/ STAGE	HP/ STAGE
Point 1	17371.14	38.05	153.49	211.89	1773	0.481	34977.43	24.83	30.6910
Point 2	16667.43	39.71	169.14	210.49	1773	0.521	33560.48	27.84	30.4873
Point 3	13213.35	41.60	257.43	198.92	1774	0.728	26590.56	46.37	28.7643
Point 4	9637.42	43.43	301.52	175.35	1777	0.720	19361.62	55.27	25.2375
Point 5	2889.86	47.21	344.64	122.83	1784	0.356	5782.96	63.20	17.4567

TEST DEVIATION FROM CURVE

values are per stage corrected to 3570 RPM

	FLOW BPD	IN RANGE	TEST HEAD	HEAD DEV	HEAD-FL % DEV	TEST HP	HP DEV	HP % CURVE	TEST EFF	EFF DEV	EFF % CURVE
Point 1	34977.43	NO	24.83	-13.73	-13.2	30.6910	-2.2155	-6.7	48.08	-21.55	-31.0
Point 2	33560.48	MAX	27.84	-13.08	-13.0	30.4873	-2.4208	-7.4	52.07	-18.82	-26.6
Point 3	26590.56	BEP	46.37	-4.35	-5.2	28.7643	-2.3741	-7.6	72.83	-0.75	-1.0
Point 4	19361.62	MIN	55.27	-2.70	-3.6	25.2375	-1.7084	-6.3	72.04	1.27	1.8
Point 5	5782.96	NO	63.20	-2.36	-3.5	17.4567	-1.5795	-8.3	35.57	1.73	5.1

VIBRATION DATA

	Peak Hz	Ampl	Peak Hz	Ampl
	Half Speed Inline		Half Speed Offset	
Top	0.00	0.000	0.00	0.000
Middle	0.00	0.000	0.00	0.000
Bottom	0.00	0.000	0.00	0.000
	Rotating Speed Inline		Rotating Speed Offset	
Top	28.80	0.022	0.00	0.000
Middle	28.80	0.042	0.00	0.000
Bottom	31.30	0.004	0.00	0.000

REDA Production Systems

**Reda Pump Performance Curve
M675A**

862 Series * - 19 Stage(s) - 3570 RPM - 61 Hz

Log No. NISP12009020402
Serial No. 2SE9A52840
2009 09:08

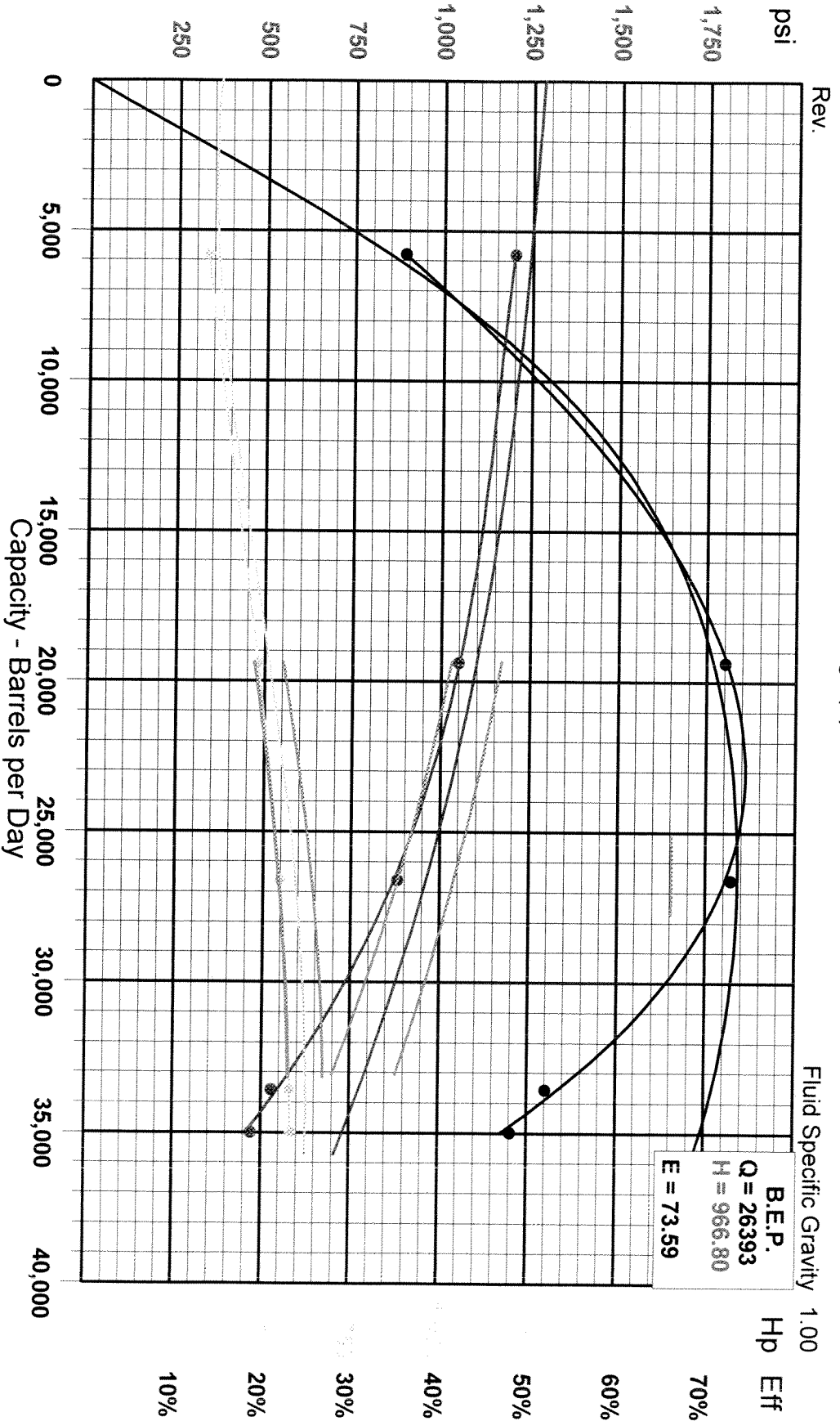

REDA

Certification of Hydrostatic Testing

Customer: HUSKYS ALLIANCE Work Order: BFP 82840 Stage & Type: M675A
 Location: 4-16-42-1244 Test Date: 02/05/09 Pump S/N: 25E94 52840
 Skid S/N: 0187-CA9

Per REDA Test Specification TS-5-127, this document certifies that the equipment listed has been hydrostatically tested and considered satisfactory since neither leaks nor seepage were observed during the specified test period.

Manufacturer's Working Pressure (PSI)	Test Pressure (PSI)	Test Fluid	Test Duration	Pass
<u>2800</u>	<u>4200</u>	<u>Propylene/ Glycol</u>	<u>30 Minutes</u>	<input checked="" type="checkbox"/>

Comments:

Certified by:

(Print Name) STEWART HOLLAND Title: ORS
 Signature:  Date: 02/05/09

CERTIFICATION OF HYDROSTATIC PRESSURE TESTING

DATE	CUSTOMER	WORK ORDER NUMBER	PART NUMBER	FLANGE SIZE
2-27-09	---	1421464	3909512	Intake 8 in. / 150
TEST PRESSURE	TEST FLUID	TEST DURATION	PASS/FAIL	SERIAL #
350	WATER	30 MINUTES	PASS	SPB8L21464

COMMENTS:

PER SCHLUMBERGER TEST SPECIFICATION TS-5-127, THIS DOCUMENT CERTIFIES THAT THE EQUIPMENT LISTED HAS BEEN HYDRO-STATICALLY TESTED AND CONSIDERED SATISFACTORY SINCE NEITHER LEAKS NOR SEEPAGE WAS OBSERVED DURING THE SPECIFIC TEST PERIOD. EQUIPMENT ALSO TESTED PER ED-197 (GEMS DOCUMENT #100098796).

TESTED BY:	SIGNATURE	DATE
Shawn Thomas		2-27-09

FORM # 100335877
REVISION AA

Schlumberger Private Information
Do not disclose, use or reproduce without written approval from Schlumberger

Warning: This controlled source document is stored within the Product Data Management (PDM) System. Any paper version of this Document is uncontrolled and should be compared with the source document at time of use to ensure it is up to date. If revisions to this document are required, please contact [redacted]

EC

Schlumberger

CERTIFICATION OF HYDROSTATIC PRESSURE TESTING

DATE	CUSTOMER	WORK ORDER NUMBER	PART NUMBER	FLANGE SIZE
10/9/08		1357459	3909102	600 / DISCH
TEST PRESSURE	TEST FLUID	TEST DURATION	PASS/FAIL	S/N
2700	H ₂ O	30 min		JDB8E57459

COMMENTS:

PER SCHLUMBERGER TEST SPECIFICATION TS-5-127, THIS DOCUMENT CERTIFIES THAT THE EQUIPMENT LISTED HAS BEEN HYDRO-STATICALLY TESTED AND CONSIDERED SATISFACTORY SINCE NEITHER LEAKS NOR SEEPAGE WAS OBSERVED DURING THE SPECIFIC TEST PERIOD. EQUIPMENT ALSO TESTED PER ED-197 (GRAMS DOCUMENT #100098796).

TESTED BY:

SIGNATURE

DATE

10/9/08

FORM # 1003358/7
REVISION AA

Schlumberger Private Information
Do not disclose, use or reproduce without written approval from Schlumberger.

Warning: This controlled source document is stored within the Product Data Management (PDM) System. Any paper version of this Document is uncontrolled and should be compared with the source document at time of use to ensure it is up to date. If revisions to this document are required please contact:

60

Recommended Spare Parts and Servicing Tools

Private

Copyright © 2008 Schlumberger, Unpublished Work. All rights reserved.

Intentionally Blank

Installation and Commissioning

6.1	Operational Checklist	6-1
6.2	Transport and Handling	6-3
6.2.1	Lifting	6-4
6.2.1.1	Forklifts	6-4
6.2.1.2	Cranes	6-5
6.2.2	Lifting Device Load Calculations	6-5
6.3	Site Requirements	6-8
6.4	Piping Connections	6-10
6.5	Commissioning	6-12
6.6	Vibration	6-18
6.7	HPS Storage	6-23
6.7.1	Preventive Maintenance	6-23
6.7.2	Motor and Pump	6-24
6.7.2.1	Ball Bearing Motors	6-24
6.7.2.2	Sleeve Bearing Motors	6-24
6.7.3	Thrust Chamber	6-24

Intentionally Blank

Schlumberger

HORIZONTAL PUMPING SYSTEM RECOMMENDED SPARE PARTS AND SERVICING TOOLS

QUANTITIES RECOMMENDED ARE FOR 1 UNIT(S) FOR 3 YEARS

SPARE PARTS				
ITEM	QTY	DESCRIPTION	P/N	WT/LBS
1.	1	Thrust Chamber Assy, 1 Bearing, G3A (1.50-6B)	100448445	275
2.	1	Shaft Seal, Type 2 Non-Cartridge	7004542	.5
3.	3	O-Ring Seal Kit, 862 Series (HSN)	100164429	1
4.	1	Seal: Bearing Isolator, Motor Side	100447640	1
5.	1	Seal: Bearing Isolator, Pump Side	100390497	1
6.	3	Thrust Chamber Oil, 5 gal (ROYAL PURPLE,SYNFILM 46 GT)	100179556	45
7.	3	O-Ring Lubricant	0553420	.3
8.	3	Motor Grease No. 2	1192640	1
9.	3	Teflon Tape, 1/2"	0588855	.06
10.	3	Coupling 1.188 x 1.375	3907128	2

TOOLS				
ITEM	QTY	DESCRIPTION	P/N	SUPPLIER
1.	1	Multimeter: Fluke model #87, True RMS, C/W Holster Test Leads & C25 Case	1048685	SLB
2.	1	Dow Corning – for pump O-Rings	3901207	SLB
3.	1	Straight Edge, 6"	0588236	SLB
4.	1	Screwdriver, 6" Blade)	0588566	SLB
5.	1	¾" Open and Box Wrench (675/862)	0593459	SLB
6.	1	Combination Wrench ½"	0593426	SLB
7.	1	Box End / Open / End Wrench, 9/16" x 5/8" (400/540)	0001164	SLB
8.	1	Wrench: Eklind #812 (3/32" – ¼")	0593491	SLB
9.	1	Macit Wrench Set, 3/16" x 3/8"	0593509	SLB
10.	1	Amp Meter Probe, Current, Clamp on	0856856	SLB
11.	2	Scissor Jack for Gen 2	100040787	SLB
12.	2	Roller Jack for Gen 1	1099878	SLB
13.	1	Feeler Gauge – (motor & pump aligning)	1192582	SLB
14.	1	Crane for TC Removal	100040817	SLB
15.	1	Box End / Open End, 1 ½" x 1 5/8"	1192590	SLB
16.	2	Grease Gun – 1 for Flex Coupling and 1 for motor	1192616	SLB
17.	2	Grease Gun Flex Hose	1192624	SLB
18.	1	Tool Box	1192632	SLB
19.	1	Seal (Non-Cartridge) Installation Tool (Plastic Cylinder)	3954255	SLB
20.	1	Small Pipe Wrench 18"	3901773	SLB
21.	1	Large Pipe Wrench 24"	3901774	SLB
22.	1	Strap Wrench, Medium SW #350-67402	3901775	SLB
23.	1	T-Handle Long Allen Wrench 3/16"	3901779	SLB
24.	1	T-Handle Long Allen Wrench 1/4"	3901780	SLB
25.	1	Crescent Wrench, 10" SW #06-46304	3901781	SLB
26.	1	Crescent Wrench, 15" SW #13-00215	3901782	SLB
27.	1	Pry Bar, 48" WT #6400-0045	3901803	SLB
28.	1	Snap Ring Pliers, Small BI-DIR, SW #13-06784x	3901805	SLB
29.	1	Pliers, Crescent: R220c	0586172	SLB
30.	1	Channel Lock Pliers 10"	3901808	SLB
31.	1	Wire Brush Set Assorted, SW #05-2267	3901817	SLB
32.	1	Rubber Mallet	3901825	SLB

33.	1	Punch & Center 5/16" Set	3901367	SLB
34.	1	8oz. Ball Pein Hammer	3901826	SLB
35.	1	3/8" Drive Ratchet Set	3901840	SLB
36.	1	Alignment Machine (Masterlign by Pruftechnik)	3901956	SLB
37.	1	Vibration	3901959	SLB
38.	1	Lubricant P-80 (used for Oil Seals & John Crane Seal Installation)	3902450	SLB
39.	1	Screw Extractor Set 3/16" – 3/4" 5 pc	3920263	SLB
40.	1	Ball End hex Keys Set 1/16" – 3/16" Standard	3920264	SLB
41.	1	Needle Nose Pliers 6 5/8"	3920265	SLB
42.	1	Thread Tap Index Set ¼-20NC – ½-20NC	3920266	SLB
43.	1	String Line Twisted Nylon Twine	3920267	SLB
44.	1	Bearing Puller Attachment 4 5/8" Max Spread	3920268	SLB
45.	1	Bearing Manual Push-Puller	3920269	SLB
46.	1	Metal File Set 5 pc	3920270	SLB
47.	1	Box End Wrench 12 pt Set (for Metastream Removal)	3920271	SLB
48.	1	Small precision Machinist Square 20 – 1 ½	3920272	SLB

6 Installation and Commissioning

6.1 Operational Checklist

1. Pre-Commissioning:

It is recommended to review the Specific Job Data Books/User Manuals, supplied with this equipment, prior to commissioning the system. Prior to starting a unit up, a thorough inspection of the equipment should be made, noting damaged or missing items.

a. Safety:

- Refer to the Hazard Analysis Risk Control Recommendations.
- Ensure correct Personal Protective Equipment and Tools.

b. Foundation:

- Ensure equipment is properly supported and anchored without distortion.
- Level skid in both planes and shim as required.

c. Piping:

- Verify piping line class ratings are acceptable for the intended equipment/service conditions.
- Ensure proper piping bracing and support spans.
- Minimize pipe strain/forces.
- Ensure adequate vents/drains.
- Note piping routing (parallel/series) and ensure line sizing is adequate for the service. Not intake piping relative to supply source.
- Verify Expansion Joints/Drop Out Spools are connected properly, if supplied.
- Verify eccentric line reduction in intake piping and concentric line increases in discharge piping, where appropriate.
- Verify piping has been hydro tested and cleaned of debris
- Ensure joints are made up correctly. Tighten and loose or leaking connections without over tightening.

- Verify proper valving: Isolation, Check, Throttling, Control, Relief, Strainers, are supplied in the system and are installed correctly and in the proper places.
- Ensure external hookups are made up: Seal Flush and Barrier Systems (Drains/Vents/Flare/Cooling Coils, etc), Drains, Vents, Instruments, Lube Cooling, etc.

d. Electrical Instruments:

- Verify proper grounding.
- Verify motor rotation, to include lube cooler motors.
- Pre-Set instrument shutdown set points.
- Check incoming line voltage, each phase. Also transformed control voltage. Match Switchgear voltage/rating to motor and power.
- Inspect makeup of all interconnecting electrical runs (Motor/Panel/Switchgear, Coolers, J-Boxes, etc). Pot any leads, where necessary.
- Megger/Continuity check wiring and instruments. Verify against wiring schematics provided.
- Verify proper ventilation/heating to prevent overheating/freezing.
- Inspect Insulated/traced lines or equipment.
- Pre-Program Variable Speed Drive/Program Logic Controller/Program Controller as necessary.

e. Lubricants:

- Ensure the Thrust Chamber and Lube Cooler are filled to the proper levels with the correct grade of lubricants.

f. Alignment:

- Align equipment using Laser Tool. Verify against Factory Supplied Data. Record.
- Ensure pumps are shimmed properly.

g. Filling/Venting:

- With discharge and drain valves closed, open inlet valve and flood system. Vent instruments and piping/pump at high points.
- Verify static pressure measurements against flange and seal ratings, switchgauge set points. Verify ample NPSHA

2. Startup:

- With unit flooded, start Booster pump, if required. Open Discharge valve to 20%. Slowly open discharge valve to the desired discharge pressure.
- Set VSD, if provided, to the desired carrier frequency/operating frequency.
- Troubleshoot as required.

3. Operational:

- Verify Pump is Operating according to the desired and specified design conditions. Record.
- Adjust set points on instruments as required. Record.
- Measure voltage and amp draw. Ensure current trip limits set and within range of the operating conditions and equipment provided. Record.
- Perform baseline vibration reading for entire drive train in both vertical and horizontal axis for all operating frequencies. Record.
- Observe Thrust Chamber Oil Temperature. Record.
- Shutdown unit and perform a Hot alignment. Record.
- Take Digital pictures of the Unit.
- Complete and retain Service Report. Sign and Date.
- Develop Maintenance Schedule with Customer.

6.2 Transport and Handling

General shipping and handling information

Horizontal pumping system (HPS) equipment is normally mounted on a rigid, non-flexible steel welded structure requiring a minimum of supportive packing. The unit can be lifted and moved with a forklift or crane-type equipment. An appropriately sized spreader bar and slings or chains must be used. Lifting eyes are located at each of the four corners of the skid to accommodate lifting.



Warning

Potential Severity: Serious
 Potential Loss: Assets
 Hazard Category: machinery equipment hand tools

Never attempt to lift the assembly from any point other than the lifting eyes on the skid.

Private

Copyright © 2008 Schlumberger, Unpublished Work. All rights reserved.

Ground transport

Ground transport via truck requires the use of no fewer than two wooden supports (4-in square by 8-ft long) placed crosswise under the skid and spaced no more than 10 ft apart. Use only straps to secure the unit, with a minimum of two tiedowns per unit. This recommendation also applies when two skids are placed side-by-side for transportation on the same platform. The straps should be placed over the skid at the location of the wooden supports. Never place a strap over the motor, thrust chamber, intake or pump. Engine-driven units may require some disassembly to meet specific clearance requirements. Secure all loose components. Provide protection from road debris.

When loading one unit, always load the motor end toward the truck cab. If loading more than one unit, the units should be staggered opposite of each other.

Ocean transport

HPS units for shipment via ocean transport should be crated or shipped in shipping containers. The client or application engineer will determine the better method.

Air transport

Air transport normally requires palletizing of the assembled skid to allow for ease of loading and unloading. Additionally, weight and balance requirements of some aircraft may require special palletization to permit transport.

6.2.1 **Lifting**

Units can be lifted with a forklift or a crane.

6.2.1.1 **Forklifts**

Ensure the forklift has the capacity to handle the HPS unit. Forklifts are rated for a given load at a distance from the mast. Since HPS units have the load located along the longitudinal axis of the skid, the centerline of the motor is the centerline of the load.

Each HPS unit has the center of gravity marked on the unit. This is the unit balance point and is determined by the manufacturer. If there is packing material or other loose items on the skid, the center of gravity will have moved.

Private

Copyright © 2008 Schlumberger, Unpublished Work. All rights reserved.

The forks must straddle the center of gravity. Distance between the forks is important. A small HPS unit can be handled by a forklift with 30– to 36–in between the forks. A full-length skid (46 ft) will require 60–in. or more between the forks.

6.2.1.2 Cranes

Two different lifting configurations are possible when using an appropriate spreader bar and slings or chains. Because the center of gravity is not at the longitudinal center of the unit, in all but a few cases, either the slings or chains are not the same length or the center lifting eye on the spreader bar will not be in the center of the spreader bar. If the spreader bar has a single (or main) lifting eye in the center, then the sling or chain on the motor side will be shorter. The spreader bar must be shorter than the unit. This is done to keep the unit from not being level when lifted. If the unit is not level when lifted, shorten the motor side sling or chain or lengthen the pump side sling or chain. If the spreader bar has the main lifting eye offset and was designed to lift the specific skid, use equal length slings or chains. The units have lifting eyes located at each of the four corners.

The crane manufacturer's load recommendations must be followed. Be especially careful of low boom angles. Follow all Schlumberger safety procedures, lifting procedures and guidelines.

Because the load on the slings or chains is not the same on each end of the skid, the loads must be calculated and compared to the ratings on the slings or chains. The slings or chains should be inspected before each use. Damaged slings or chains should be repaired or discarded.

6.2.2 Lifting Device Load Calculations

h Hint

A calculator with trigonometric functions is useful for making lifting calculations.

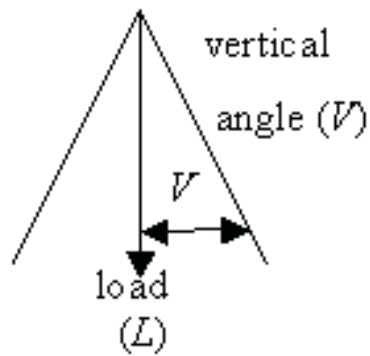

Term	Definition
L	load to be lifted
R	load on the lifting device
C	cosine of the maximum vertical angle

then

$$L=RC$$

$$R=L\div C$$

Angle	Cosine
15°	0.966
25°	0.906
30°	0.866
35°	0.819
40°	0.766
45°	0.707
50°	0.643
60°	0.500
70°	0.342

When the vertical angle is increased, the load on the sling will be increased by a factor that is the cosine of the vertical angle. If any two terms of the equation are known, the equation can be used to solve for the third term.

Private

Copyright © 2008 Schlumberger, Unpublished Work. All rights reserved.

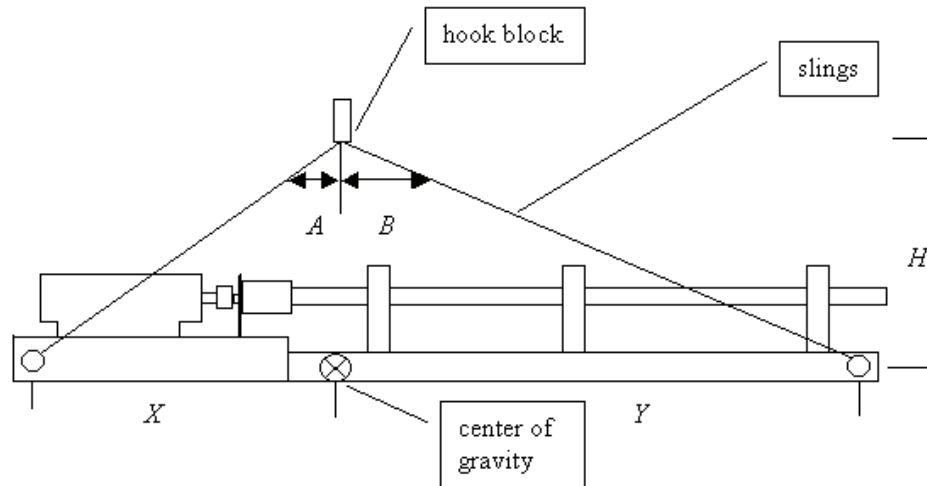

Example

A HPS unit weighs 13,000 lbm and its length is 35 ft. The unit will be lifted with a crane and slings. Determine the strength requirement of the slings and verify the loads. The hook block must remain over the center of gravity.

Calculate the load on each sling —

$$R=L\div C$$

$$R=(13000\div 4)\div C$$

The weight of the unit is divided by four because there are four slings. The cosine of the angle C should be the larger of the two A or B .

A or B are determined by measuring the distance from the hook to the center of gravity, ensuring that the hook is tight against the slings. The angle A or B is the arc tangent of the distance from the center of gravity divided by the height.

$$A=\arctan(X\div H)$$

$$B=\arctan(Y\div H)$$

For this example, $X = 13$, $Y = 22$, $H = 15$

$$A=\arctan (13\div 15) = 40.9^\circ$$

$$B=\arctan (22\div 15) = 55.7^\circ$$

Private

Copyright © 2008 Schlumberger, Unpublished Work. All rights reserved.

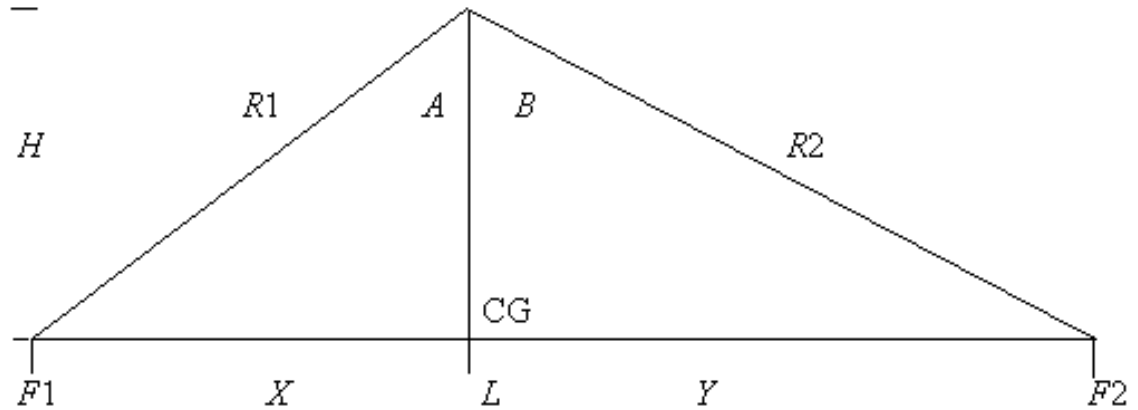

$$F1 = L(y \div [x+y]) = 13000(22 \div [22+13]) = 13000(22/35) = 8171.4 \text{ lbm}$$

$$F2 = L(x \div [x+y]) = 13000(13/35) = 4828.6 \text{ lbm}$$

$$R1 = F1 \div \cosine A = 8171.4 \div 0.756 = 10810.9$$

$$R2 = F2 \div \cosine B = 4828.6 \div 0.564 = 8568.5$$

$R1$ is the greater load so the slings should be sized to lift $R1 \div 2$ (two slings on each end) or $R = 5405$ lbm. The slings should have a minimum rating of 6000 lbm each.

6.3 Site Requirements

The horizontal pumping system (HPS) is shipped fully assembled or in several sections. The HPS unit is built in sections if the overall unit length exceeds shipping limitations. The unit sections are aligned during manufacturing and testing. During the installation procedure, all alignments must be checked.

The installation site should be level with adequate drainage. The client should determine if the unit is set on a concrete pad or on a support system. The support must be adequate to prevent misalignment when the unit is in operation.

Gravel pad

A HPS unit can be set on a gravel pad with no supports, however, this practice is not recommended. It is difficult to level the unit and prevent the unit from being out of alignment. Many units are placed in service with gravel-only support. In these cases, the most important action is to verify the pump is straight and the motor and thrust chamber are aligned.

Steel, wood or concrete supports

Private

Supports made of steel, wood or concrete can be used. When one of these supports are used, it is important the earth under the supports is compacted and covered with three to four in. of gravel. The skid should be level in both directions on the supports. The base rail of the skid should be shimmed between the rail and the support. The motor end of the skid should have two supports, one located under the mounting bolts at the fan end of the motor and the other support should be located under the motor-to-thrust chamber coupling. Other supports should be equally spaced down the remaining skid no more that 10 ft apart.

Reinforced concrete pad

Field preparation should include a reinforced concrete pad built in accordance with the dimensional HPS drawing, dimensional skid footprint drawing, system weight, and the environmental conditions associated with the installation site. As a general recommendation, the reinforced concrete pad should be rated for 250% of the combined weight of the electric motor or engine and the support skid (250 lbm per foot of length). The pump section of the skid is typically lighter in weight per foot of length than that of the electric motor or engine. The skid should be level in both directions on the pad. The base rail of the skid should be shimmed between the rail and the pad. Do not allow the bottom rail to be unsupported for a length more than 10 ft under the pump and 5 ft under the motor section.

Clearance instructions

The skid clearance for operation should be a minimum of three ft in all directions from the system pump/motor axis except for electric and mechanical connections. The overhead clearance should allow for use of a forklift or winch system to aid in equipment removal and replacement.

Refer to the motor or engine manufacturer's recommendation for ventilation clearances to prevent excessive temperature rise. All system enclosures or buildings should allow for natural convection air circulation at rates that do not allow for excessive temperature rises that may affect motor/engine, starter, and thrust chamber life. Ambient air temperatures greater than 104 degF (40 degC) require special components and design considerations to prevent reduced motor/engine, starter and thrust chamber life.

Clearances mentioned in this section are provided as a general guide and may be superseded by requirements based on class or division rating of a specific system's site location. Local codes, specifications or regulations in the state or country may apply.

6.4 Piping Connections

Proper connection of suction and discharge piping to the horizontal pumping system (HPS) unit is very important. The care used when making fit-ups will affect the equipment runlife and may prevent leaks.

Allowable loads (nozzle loading)

Nozzle loading is defined as the forces and moments induced on the pump flange by the connecting piping. Proper piping configurations will eliminate misalignment between the pump and the driver and may prevent flange leaks.

Factors that determine the forces and moments are:

- weight of the connection piping
- amount of thermal growth
- misalignment of the mating pipe flanges

The pipe weight should be supported by a pipe support located a short distance from the companion flange and extending to the pump intake flange. The pipe support should be adjustable so that the companion flange and pump intake flange can be accurately aligned.

The maximum operating temperature for HPS units is 200 degF (93 degC). The units are limited to this temperature to prevent thermal growth from becoming a problem. HPS units can be operated at higher temperatures if certified by the Product Center.

Flange alignment is very important. The ASME piping code B31.3 (1996) states “Any distortion of piping to bring it into alignment for joint assembly which introduces a detrimental strain in equipment or piping components is prohibited.” In the case for HPS units, before installing bolts, flange faces should be aligned to the design plane within 0.0625 in/ft (1 mm/200 mm) measured across any diameter (see [Figure 6-1](#)). Flange bolt holes should be aligned within 0.125 in. (3 mm) maximum offset (see [Figure 6-2](#)).

Private

Copyright © 2008 Schlumberger, Unpublished Work. All rights reserved.

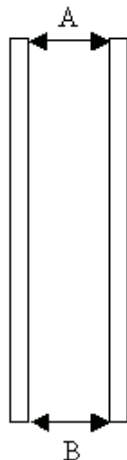

A – B less than or equal to 0.0625 in./ft
of flange width

Figure 6-1: Allowable flange alignment

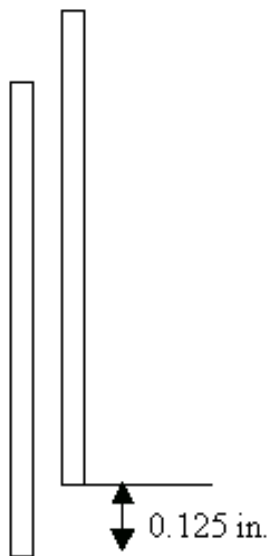

Figure 6-2: Maximum offset for bolthole alignment

Bolting should conform to the following guidelines.

Private

Copyright © 2008 Schlumberger, Unpublished Work. All rights reserved.

- When assembling flanged joints, the gasket should be uniformly compressed to the proper design loading.
- Caution should be used when assembling flanged joints where the flanges have widely differing mechanical properties. Tightening to a predetermined torque is recommended.
- Bolts should extend completely through the nuts with at least one complete thread showing beyond the nut.

The practice of “loose bolting” should be used; if the flanges are parallel and aligned so that the bolts can be inserted by hand with force, then the flanges are aligned properly. Tighten the bolts or nuts using an alternating pattern (see [Figure 6-3](#)).

**Note**

Flanges should be inspected for damage prior to assembly. A scratch or gouge on the flange face may cause a leak. Replace damaged flanges.

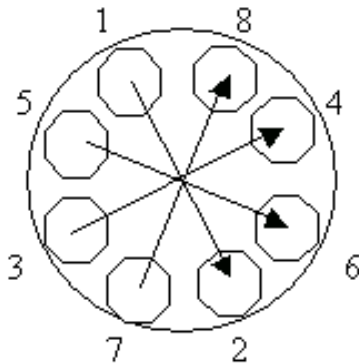

Figure 6-3: Flange bolt tightening sequence

6.5 Commissioning

Safety

Private

Copyright © 2008 Schlumberger, Unpublished Work. All rights reserved.

- Verify that all components of the discharge piping have a pressure rating greater than the discharge pressure of the HPS.
- Be aware of high-pressure fluid hazards such as leaks, splits and high-pressure hoses.
- Operate valves slowly and smoothly.
- Be aware of fluid contamination hazards.
- Wear appropriate personal protective equipment.

**Note**

Ensure the equipment is electrically grounded.

**Note**

Ensure that lockout/tagout procedures are reviewed with all personnel and are followed.

**Danger**

Potential Severity: Catastrophic
Potential Loss: Personnel
Hazard Category: human

Lockout/tagout procedures must be followed any time work is performed on the HPS, but risk of catastrophic injury is extremely high if the unit is started with a shaft locked down.

Private

Copyright © 2008 Schlumberger, Unpublished Work. All rights reserved.

**Note**

During installation or commissioning, the HPS unit should never be run dry. The bearing system in the pumps and the shaft seals require fluid for cooling. Running the unit without fluid, even for a short period of time, can cause premature bearing or seal failure.

Introduction

Qualified personnel are essential during start-up. Obvious faults may go unnoticed if personnel are unfamiliar with the equipment. The first task of the commissioning team is to check the HPS installation. Centrifugal pumps can seize at start up due to incorrect start-up procedures.

Commissioning Fluid

The pump may be commissioned on water if the regular product is not available, however, this can result in damage to the unit if the commissioning conditions are very different from the design datasheet conditions.

Risk of Upthrust Damage on Large-Volume Pumps

Upthrust damage can occur in compression-style pumps if a booster pump is used and has sufficient flow to cause the pump to rotate while the piping system is being charged. The damage occurs when liquid flow through the pump pushes the impellers towards the discharge end of the pump. If the pump is turning, the contact between the impeller and the upthrust pad on the diffuser will cause severe wear.

Preventing Thrust Damage at Startup

Allow only sufficient liquid to flow through the pump to remove any air. If the piping design requires high booster pump flow, the HPS shaft should be locked down.

**Note**

Ensure the motor panel is locked out and the clamp is removed prior to starting.

Starting the HPS Unit

Private

Copyright © 2008 Schlumberger, Unpublished Work. All rights reserved.

- 1 Close the suction and discharge valves.
- 2 If a time-delay relay is installed in the low-discharge-pressure circuit, set the pressure switches. (Follow procedure below.) Otherwise, set the pressure shutdown switches after the unit is stabilized and running.
- 3 Perform all required pre-start checks.
- 4 Slowly open the suction valve to full-open position and observe the suction pressure gauge.
- 5 Fill the pump. When initially filling the pump, it is likely that air will become entrained in the pump. The air must be evacuated before starting the HPS unit. This can be accomplished by filling the pump with fluid and then opening the small bleeder valve on the top of the pump case at the discharge end. Close the valve as soon as the airflow through the bleeder valve has stopped. If the HPS unit is not equipped with the bleeder valve, evacuate the air by loosening the pressure shutdown switch hydraulic hose connection on the pump case at the discharge end. Tighten the switch hose connection as soon as the airflow has stopped.
- 6 Perform a conditional inspection and verify that the unit is ready to start.
- 7 Partially open the discharge valve. Twenty percent of full open is recommended as a starting point.
- 8 Position yourself to carefully observe the direction of rotation (clockwise when looking from the back of the motor towards the pump).
- 9 Start the unit. If the rotation direction is not correct, shut off and reverse two of the motor leads at the starter. If the rotation direction is correct, go to the next step.

***i* Note**

Electric motors over 200 horsepower (150 kW) may have starting limitations. The motor manufacturer may limit the number of starts in a given time period and/or require a certain amount of time between starts. If a motor has starting limitations, the limitations will be listed on the motor data plate. Review the motor data plate prior to starting the motor.

- 10 Monitor the suction and discharge pressures (and the inrush amperage and voltage if possible).
- 11 Slowly open the discharge valve as the pump pressure builds (attempt to maintain design pressure).

Private

- 12 Verify actual flow and pressure compared to the design datasheet as the system fills and stabilizes.
- 13 Adjust the pressure shutdown switches and perform a vibration analysis and a hot alignment procedure in accordance with the following procedures.

Pressure Shutdown Switch Adjustments

- 1 Allow the HPS unit to run and stabilize at the desired flow and pressure
- 2 Set both pressure shutdown switches. There are high and low limits for each switch. If a time-delay relay is installed in the low-discharge-pressure switch circuit the switches should be set prior to starting the unit. There are at two factors to consider when choosing the high and low limits for the pressure switches.
 - Safety and environmental concerns must be considered. A pressure increase above system maximum allowable operating pressure (MAWP) because of blocked or shut-in piping can be hazardous. A pressure decrease due to leaking or failed piping or system processes can cause pump or seal damage. Thus, the high and low pressure limits should be set slightly above and slightly below the normal system operating pressures.
 - Protection of the HPS unit and its components must be considered. For example, operating the pump beyond its recommended operating discharge pressure range can cause equipment damage. The pump curve supplied with each HPS unit shows that particular pump's recommended high- and low-flow limits. The curve in the databook is for a specific fluid specific gravity and pump speed. Changes in either will result in the shutdown switches being improperly set. The limits are shown as two dark vertical lines on the pump curve. Thus, the two points at which these two dark vertical lines cross the line representing the head produced by the pump are the appropriate low- and high-flow pressure limits for the pump. These two pressure points, read on the left scale of the pump curve, should be used as the limit points when setting up the discharge pressure switch (with regard to equipment protection).
 - The suction pressure switch high limit should be set at a point that is 10% to 20% less than the pressure rating of the suction flange and/or the HPS intake jacket. The switch low limit point should be set at the minimum pump NPSHR. The pump should never be run dry; this can cause immediate failure of the pump.

Private

Copyright © 2008 Schlumberger, Unpublished Work. All rights reserved.

Vibration Analysis

Vibration measurements should be taken with either a Vibrotip, a CSI 1900 or similar equipment while the HPS unit is operating. Out-of-specification vibrations should be identified and repaired.

Set the vibration switch when all vibration measurements are in specification.

1. With the unit running, the sensitivity knob on the vibration shutdown switch should be slowly adjusted to increase the sensitivity until the switch activates and the motor stops running.

***i* Note**

On a large unit with a motor that has a limited number of starts per hour [usually two] the vibration switch wiring is jumpered closed in the junction box and then the wires are disconnected at the switch. This allows the pump to run while the switch is being adjusted.

-
2. Adjust the vibration switch back 1/8 turn in the opposite direction. The vibration switch is manually reset and is now operational.

***i* Note**

If the wiring was disconnected to make the adjustment, first connect the wires at the switch and then remove the jumper. If the vibration switch activates and stops the motor, decrease the sensitivity another 1/8 turn.

-
3. Recheck the vibration level using a meter. If the vibration has increased since the first reading determine the cause and repair.
 4. Allow the unit to operate for one hour.
 5. Record the thrust chamber 'hot run' oil temperature. This will establish a baseline temperature for future reference.

Hot Alignment Procedure

Shut down the HPS after one hour and perform a hot alignment procedure. The hot alignment procedure typically reduces vibration dramatically in the new installation. This revised baseline figure will also allow a benchmark value to be used in the future to verify alignment accuracy, and present a tangible servicing benefit to the client. Perform another vibration analysis after the hot alignment is performed.

Private

Copyright © 2008 Schlumberger, Unpublished Work. All rights reserved.

6.6 Vibration

The vibration standard for testing submersible pumps is American Petroleum Institute (API) 11S 8. This standard relates to pumping units designed for and used in downhole environments. All Artificial Lift pumps are tested for vibration during the post-assembly performance test per the API standard. Horizontal pumping systems (HPS) use a submersible pump in a surface mounted, horizontal configuration with a conventional foot mounted driver. Consequently, the vibration dynamics of the system are different than a pump used in a submersible system. The following content discusses various aspects of vibration for horizontal pumping systems and the limits necessary for acceptable equipment runlife.

Vibration Theory

Any mechanical system that possesses mass and elasticity is capable of relative motion. If this motion repeats itself after a given time period it is known as vibration. Vibration in rotating machinery is caused by unequal forces acting around a centerline. The forces can be caused by

- unbalance
- poor alignment
- electrical forces in the motor
- hydraulic forces from the pumped fluid.

Structure and Foundation Considerations

The type of structure that any rotating machine is mounted on will influence the vibration level. For example, vibration data from a given flow and backpressure on a 23–stage M520A with a 500 HP TEFC motor mounted on a Model 88 skid will be different, but similar to, vibration data for the same pump and motor mounted on a Model HD skid. This is because the skids are designed differently. The configuration of the steel member makes a difference in the way the skid responds to the relative motion of the moving parts and the fluid flowing through the pump. This means that the vibration data recorded at the test facility may not be comparable to the vibration data observed at the field site. This lack of repeatability makes comparisons difficult.

Private

Copyright © 2008 Schlumberger, Unpublished Work. All rights reserved.

Generally the more rigid the mounting structure and the more secure the HPS unit is attached, the lower the magnitude of the measured vibration will be. It can be suggested that the HPS skid should be bolted or welded to the foundation to minimize vibration if the vibration is being enhanced by resonance, however, this is only true if the skid anchoring does not induce any misalignment of the components. This misalignment includes

- pump straightness
- pump-to-intake jacket fit up
- thrust chamber to motor alignment
- soft foot in the motor
- piping loads on the intake and discharge nozzle.

The foundation structure should be rigid to minimize the resonance effect of the pump assembly. A concrete pad with the top surface flat to 1/16 in is best. The pad should be larger than the outside dimensions of the skid and from 4 to 12 in thick. The thickness required is proportional to the motor size.

The converse of a concrete pad is a steel deck mounted on a flexible substructure. An example of a flexible structure is a deck on an offshore platform. If other rotating equipment is operating on the same deck, vibrations from the other equipment may affect the HPS vibration level. For reference purposes, vibration data from other rotating equipment should be recorded without the HPS unit running.

Vibration Measurement

The type of vibration monitoring of any rotating equipment depends on the desired result. Two specific equipment types are recommended for horizontal pumping systems; one gives the magnitude of the vibration at a given frequency, i.e. 1.5 mils (or 0.278 in/sec) at 3550 rev/min, the other gives a single number based on a weighted average.

If vibration testing is performed to diagnose the cause of the vibration, a spectrum analysis is used to locate and diagnose unwanted vibration. The spectrum analysis is a display of the magnitude of vibration in mils (1 mil = 0.001 in) or in/sec at various frequencies. The output is typically rendered as a graph with magnitude on the vertical axis and frequency on the horizontal axis. The frequency range is from zero to several times the actual speed of the equipment. This is the best data for troubleshooting and repair determination.

Private

A simpler and less costly type of monitoring is better suited for trend analysis in the field environment. International Standards Organization (ISO) Standard 10816–1 is a non-frequency based standard that provides appropriate trend analysis and acceptance criteria. (The predecessor to ISO 10816–1 is ISO 2372, Mechanical vibration of machines with operating speeds from 10 to 200 rev/s - Basis for specifying evaluation standards.)

The location of vibration points should be the same for all units except multiple pump units. Data should be taken in the vertical plane only. This reduces the effect of reduced stiffness in the horizontal plane. The figure below shows typical vibration test points on a HPS unit. The points shown in [Figure 6-4](#) are the head, base and middle of each pump, the front and rear thrust chamber bearings and the front and rear motor bearings.

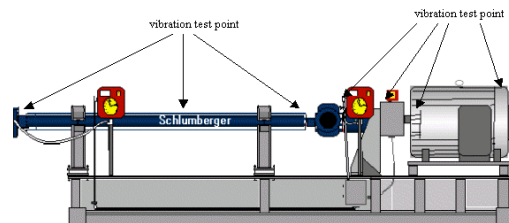

Figure 6-4: Typical vibration test points on a HPS unit

Recommended vibration measurement instruments are either a CSI-1900 or a Prüftechnik AG Vibrotip. Both are available from Artificial Lift Production Systems. The CSI-1900 measures the vibration magnitude at a given frequency. The Vibrotip measures vibration severity. Since both types of measurements are acceptable, the choice should be based on instrument availability and desired testing result.

Vibration Magnitude

The maximum allowable vibration for an electric motor driven unit is shown in [Figure 6-5](#). The graph plots displacement in mils as a function of the shaft speed. [Figure 6-5](#) is used only with a vibration meter such as the CSI-1900 that measures displacement at a given frequency.

To convert the reading in mils to in/sec the following equation can be used

$$V_{\text{Peak}} = 52.3DF \times 10^{-6} \text{ or } D = V_{\text{Peak}} / 52.3F \times 10^{-6}$$

where

Term	Definition
VPeak	vibration velocity, in/sec

Private

Copyright © 2008 Schlumberger, Unpublished Work. All rights reserved.

D	peak to peak displacement, mils (1 mil = 0.001 in)
F	frequency, cycles/min

i Note

$$V_{rms} = V_{peak\ to\ peak} \times 0.707$$

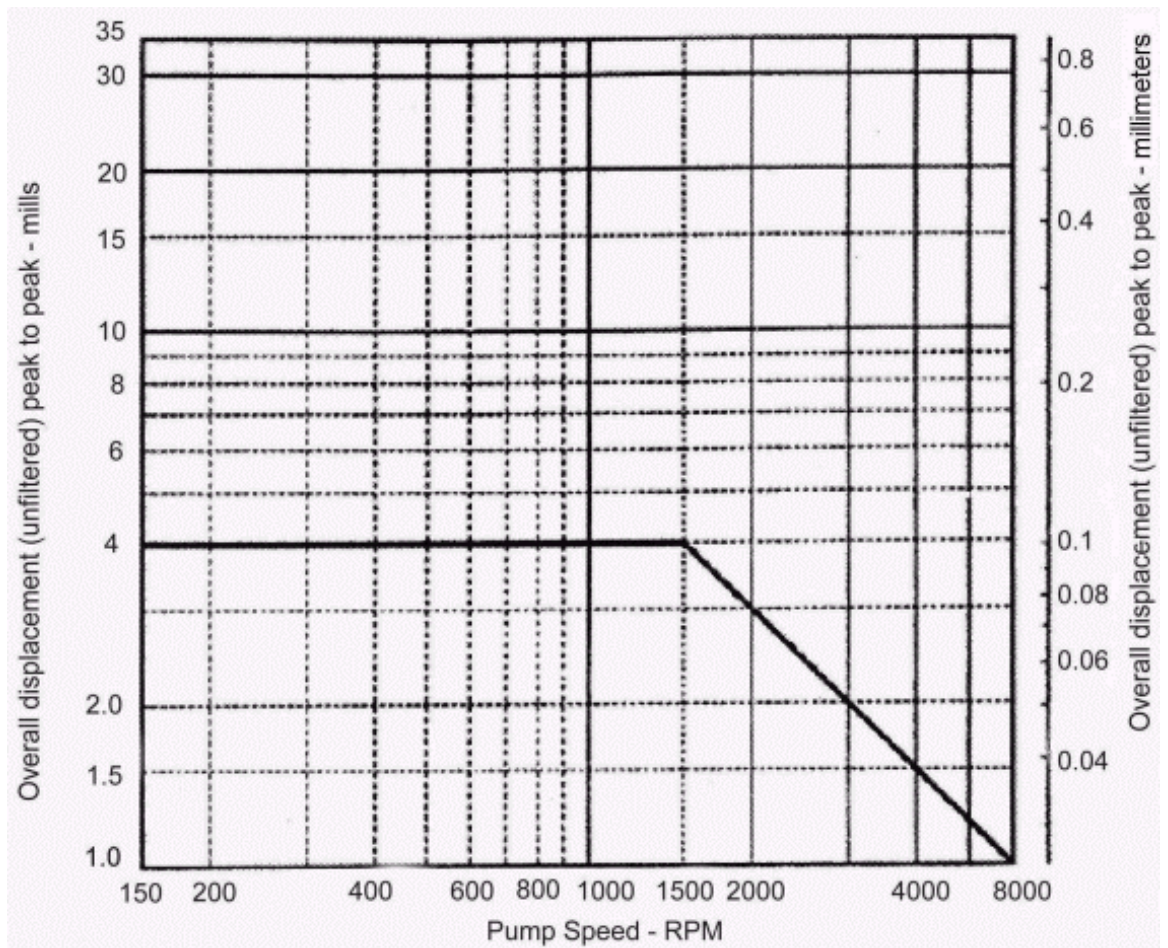

Figure 6-5: Maximum allowable electric motor vibration limits

Private

Copyright © 2008 Schlumberger, Unpublished Work. All rights reserved.

eg Example

The CSI-1900 measurement is 0.15 in/sec (peak to peak) at 3570 rev/min. Does this meet specification?

$$D = V_{\text{Peak}} / 52.3F \times 10^{-6}$$

$$D = (0.15) / (52.3)(3570) \times 10^{-6}$$

$$D = 0.8$$

From the figure above, the maximum displacement allowed is 1.6 mils, therefore, the vibration is approximately half of the allowable.

The maximum allowable vibration level for an engine-driven unit is greater than an electric motor driven unit. Caterpillar has established a standard of four mils for a bare engine and five mils for a generator set. Since the gearbox used on an engine-driven unit is similar to a generator, the five mil limit is the maximum allowable vibration limit for the engine portion of the unit. It is very important that the vibration from the engine does not affect the vibration readings on the pump skid. This is dependent on the engine and the pump skid foundation. For example, a concrete pad will not transmit the same amount of vibration as a suspended structure. A steel building or platform deck are examples of a suspended structure. The recommended method is to measure the vibration at the specified locations on the pump skid with the engine running at the rated speed with the driveline disconnected. The readings represent the 'background' vibration level. If the measured vibration magnitude exceeds one-third of the recommended limit, it may then be necessary to reduce the magnitude of the background vibration. Many solutions exist and the best approach may be a combination of several options. Contact InTouch for engineering assistance.

Vibration Severity

Another method of vibration measurement measures vibration severity. The concept of vibration severity is explained in detail in the ISO 10861-1 document. Vibration severity is defined as the maximum broad-band magnitude value measured under agreed machine support and operating conditions. The Prüftechnik AG Vibrotip meter measures vibration severity. The maximum allowable vibration for HPS units as measured by the Vibrotip is:

Private

Term	Definition
electric drive	0.4 in/sec peak or 0.28 in/sec rms
engine drive	0.5 in/sec peak or 0.35 in/sec rms

The same problem with vibration from other sources also applies to the Vibrotip. If the base that the HPS is mounted on experiences vibration before the HPS motor is started, then the true vibration level for the HPS will be the difference between the non-running and the running measurement.



Tip

Vibration measuring is the second most important element of preventive maintenance (after proper lubrication). The vibration level must be within acceptable limits. A change in vibration level over time (trend analysis) is important. Trend analysis allows for the maintenance of rotating equipment to minimize operating costs and maximize run life.

6.7 HPS Storage

A horizontal pumping system (HPS) should be considered in storage when the unit has been delivered to the jobsite but has not been installed or the unit has been installed but fluid has not been pumped.

The HPS should be decommissioned if it will not be installed and operated within 14 days after arrival.

6.7.1 Preventive Maintenance

Protect the unit from temperature extremes. Heat and UV radiation can damage the paint and rubber components. If the unit was designed to operate inside a building then it should be covered if stored outside. The pump and seal will be damaged by cold weather. Do not expose the unit to freezing temperatures. The fluid used to preserve the pump and intake section freezes at -4°F (-20°C).

Water can be trapped behind the stages in the pump and in the seal flush. This water will freeze and damage the pump at freezing temperatures.

Private

6.7.2 Motor and Pump

Do not remove the cover from the intake or discharge flange. Do not drain any liquid from the pump or intake. The liquid shipped inside the pump will protect the pump and seal.

Rotate the motor and the pump 10 revolutions weekly. If the motor, thrust chamber/pump assembly or the combination will not turn determine the cause and repair. Failure to rotate the equipment will result in early equipment failure.

6.7.2.1 Ball Bearing Motors

On units with ball bearing motors, the coupling is shipped connected to the thrust chamber. The motor and thrust chamber/pump can be turned as one unit. The motor and thrust chamber/pump combination will turn easily; in many cases the unit will turn by hand. If required, a strap wrench can be used to turn the motor and thrust chamber/pump and will prevent damage to the coupling.

6.7.2.2 Sleeve Bearing Motors

Motors with sleeve bearings are shipped with the coupling disconnected and the motor shaft blocked in place. The oil reservoir for each bearing has been drained. The motor shaft should be unblocked and oil reservoirs filled with turbine oil. The correct viscosity of the oil will be on a dataplate on the motor. Do not connect the coupling. The motor will have to be aligned and the coupling will be in the way. Sleeve-bearing motors are hard to rotate. A large strap wrench is recommended for rotating the motor.

6.7.3 Thrust Chamber

The thrust chamber is shipped with the proper amount of lubricant. Periodic rotation of the thrust section will retard oxidation.

Maintenance

7.1	Lubrication Maintenance Summary	7-1
7.2	Recommended Maintenance Schedules	7-2
7.3	HPS Field Service Report	7-3
7.4	Decommissioning Procedures	7-7
7.4.1	Short-Term Decommissioning Procedures	7-7
7.4.2	Long-Term Decommissioning Procedures	7-8
7.5	Recommissioning Procedures	7-9

Intentionally Blank

7 Maintenance

7.1 Lubrication Maintenance Summary

Lubrication requirements for the motor and thrust chamber are shown in [Table 7-1](#). A lubrication chart for standard systems is shown in [Table 7-2](#). A lubrication chart for flush-plan systems is shown in [Table 7-3](#).

Table 7-1: Lubrication requirements for the motor, and thrust chamber

Component	Lubrication intervals
motor	Lubricate every three months for 24 hr/day service. Use grease (p/n 1192640) or as recommended in the motor section maintenance sheet.
thrust chamber	Use only recommended oil (Royal Purple, p/n 100179556). Change the oil every six months of continuous service.

Table 7-2: Lubrication chart for standard systems

	Thrust Chamber Lube Oil	O-Ring Lubricant ¹	Motor Grease	Test Fluid
Part Number	100179556	3901207	1192640	1014778
Technical Specification	Royal Purple Synfilm 46 GT	D-22	C-152	D-89
Quantity for First Fill	none	none	none	none
Quantity for Maintenance	4 qt (change)	none for routine maintenance	as required	test and ship only
Estimated Annual Average Consumption	12 qt	none (only needed for equipment change out)		test and ship only
Quantity to be Stocked	30 gal	2, 5.3-oz tubes	6, 14-oz tubes	test and ship only
Shelf Life	4+ Years	5 years	2+ years	years

¹ This o-ring lubricant (Dow Corning No. 55) is not recommended for use as a lubricant on silicone o-rings and John Crane seals.

Table 7-3: Lubrication chart for flush-plan systems

	Thrust Chamber Lube Oil	Barrier Fluid	O-ring Lubricant ¹	Motor Grease	Test Fluid
Part Number	100179556	7003973	3901207	1192640	1014778
Technical Specification	Royal Purple Synfilm 46 GT	synthetic lubricant	D-22	C-152	D-89
Quantity for First Fill	none	none	none	none	none
Quantity for Maintenance	6.5 qt (change)	as required	none for routine maintenance	as required	test and Ship Only
Estimated Annual Average Consumption	13 qt	5 gal	none (only needed for equipment change out)		test and ship Only
Quantity to be Stocked	30 gal	15 gal	2, 5.3-oz tubes	6, 14-oz tubes	test and ship only
Shelf Life	4+ years	2+ years	5 years	2+ years	years

¹ This o-ring lubricant (Dow Corning No. 55) is not recommended for use as a lubricant on silicone o-rings and John Crane seals.

7.2

Recommended Maintenance Schedules



Note

The HPS unit should be running while performing Task 1, Task 2 and Task 3. The HPS unit should shut down and locked out for the remaining tasks.

Task	Task Description	Daily	Monthly	Quarterly	Semiannual
1	While the HPS unit is operating, listen and feel for changes in sound and vibration level.				
2	Perform vibration and alignment checks.	N/A	N/A		
3	Verify the shutdown setting has not been changed and instruments are functioning.				
4	Inspect suction and discharge connections for leaks.				
5	Inspect the thrust chamber for leaks.				
6	Inspect the mechanical seal for leaks.				

Private

Copyright © 2008 Schlumberger, Unpublished Work. All rights reserved.

Task	Task Description	Daily	Monthly	Quarterly	Semiannual
7	If the HPS unit is equipped with a thrust chamber cooling system, inspect the cooling system for leaks and clean the radiator.				
8	Check the thrust chamber or thrust chamber cooling system oil level.				
9	If the HPS unit is equipped with electric motor bearings that are lubricated with oil, change the oil.				
10	Inspect the skid for damage due to external forces.				
11	Inspect the HPS unit for cleanliness, especially the electric motor fins, thrust chamber and mechanical seal.				
12	If the electric motor bearings are lubricated with grease, lubricate the bearings in accordance with motor manufacturer recommendations.	N/A			
13	If the HPS unit runs on an intermittent basis and the unit does not have a thrust chamber cooling system, change the thrust chamber oil.	N/A	N/A		
14	Change the thrust chamber oil regardless of accessories.	N/A	N/A	N/A	
15	If the HPS unit is equipped with a lubricated coupling, inspect the coupling for grease leaks.	N/A	N/A		
N/A — not applicable					

7.3 HPS Field Service Report

Table 7-4: Client and Date of Report

Client:	Date:
---------	-------

Table 7-5: General Information

Service report No.		Field	
Field sales order No.		Well No.	

Private

Copyright © 2008 Schlumberger, Unpublished Work. All rights reserved.

Lead representative		Country	
Second representative		Lease	
CSO number		State	
Client PO		Client Representative	

Table 7-6: Pump Data

Stage type		Shaft size	
Series		Metallurgy	
Construction/thrust		Discharge flange	
	Section 1 (intake end)	Section 2	Section 3
Housing size			
Number of stages			
SLB part number			
Serial number			
In-service date			

Table 7-7: Motor Data

Manufacturer		Enclosure	
HP rating		RPM	
Nameplate voltage		Nameplate amperage	
Frame		SLB part number	
Model number		In-service date	
Running voltage		Starter/controller	

Table 7-8: Engine-Driven Units

Engine manufacturer		Engine model number	
Engine serial number		HP/KW rating	
Engine operating speed		Fuel type	

Private

Copyright © 2008 Schlumberger, Unpublished Work. All rights reserved.

Speed increaser manf.		Speed increaser model	
Speed increaser s/n		Input/output ratio	

Table 7-9: Thrust Chamber and Intake Assembly

Model		Metallurgy	
Series		SLB part number	
Serial number		Intake pressure rating	
Intake pressure (actual)		Flange size and type	
Flange part number		In-service date (TC)	
TC/motor coupling type			

Table 7-10: Shutdown Switches

Settings	Found at		Left at		Operational
	High	Low	High	Low	
Intake					
Discharge					
Vibration					

Table 7-11: Observed Operating Parameters

Discharge pressure		Discharge rate		Cycling	
Cycles in 24 hr.		Pumping fluid		Fluid S.G.	
Fluid temperature		Sand, scale, H ₂ S, CO ₂ , other			

Private

Copyright © 2008 Schlumberger, Unpublished Work. All rights reserved.

Table 7-12: Motor Maintenance Check List

Motor	Service performed	Condition
Motor bearings lubricated		
Air intake ports cleaned		
Motor properly grounded		
Comments		

Table 7-13: Thrust Chamber Maintenance Checklist

Thrust chamber	Service performed	Condition
Oil changed		
Retainer seal (motor side) checked		
Retainer seal (intake side) checked		
Shaft seal (intake) checked		
Weep hole drain port cleaned		
Sight glass cleaned		
Comments		

Table 7-14: Metastream Spacer Coupling Maintenance Checklist

Metastream Spacer coupling	Service performed	Condition
Inspect hub and spacer for wear		
Check coupling alignment		
Comments		

Table 7-15: General Operation Checklist

General operation	Service performed	Condition
Check skid/mounting bolts		
Hi/Lo discharge pressure switch		

Private

Copyright © 2008 Schlumberger, Unpublished Work. All rights reserved.

General operation	Service performed	Condition
Hi/Lo intake pressure switch		
Vibration switch		
Operating parameters checked		
Additional service or repair required/recommended		

Table 7-16: Vibration Measurements

Location	30 Hz amplitude	60 Hz amplitude	120 Hz amplitude
Intake vertical			
Intake horizontal			
Mid-pump vert. (I/D)			
Mid-pump horz. (I/D)			
Discharge vertical			
Discharge horizontal			
Motor vert. bearing			
Motor horz. bearing			

7.4 Decommissioning Procedures

7.4.1 Short-Term Decommissioning Procedures

The following decommissioning procedures should be performed for horizontal pump systems that will be idle for more than 14 days but less than 4 months.

1. Perform necessary lock-out/tag-out procedures before beginning any work.
2. Close intake and discharge valves.
3. Drain fluid from the pump.

Private

Copyright © 2008 Schlumberger, Unpublished Work. All rights reserved.

4. Flush the pump with clean fluid. (Water if the pumped fluid was water based and diesel if the pumped fluid was oil based.)
5. Fill the pump with preservation fluid. (Glycol if the pumped fluid was water based and diesel if the pumped fluid was oil based.)
6. Check the oil level in the thrust chamber. Replenish as necessary.
7. Ensure the motor bearings are adequately lubricated.
8. Remove the motor-to-thrust chamber coupling guard so that the motor and pump can be periodically rotated.
9. Using a strap wrench on the motor shaft, rotate the pump and motor 10 revolutions once a week.
10. Check the pump preservation fluid level on a weekly basis and replenish as necessary.

7.4.2 Long-Term Decommissioning Procedures

The following decommissioning procedures should be performed for horizontal pump systems that will be idle for more than four months.

1. Perform necessary lock-out/tag-out procedures before beginning any work.
2. Close intake and discharge valves.
3. Drain fluid from the pump.
4. Flush the pump with clean fluid. (Water if the pumped fluid was water based and diesel if the pumped fluid was oil based.)
5. Fill the pump with preservation fluid. (Glycol, if the pumped fluid was water based and diesel if the pumped fluid was oil based.)
6. Fill the thrust chamber completely full of oil. Oil should be visible in the fill spout. This action will prevent condensation in the thrust chamber. If the HPS is equipped with a heat exchanger or remote mounted tank, close the valve in the return line from the thrust chamber.
7. Ensure the motor bearings are adequately lubricated.
8. Remove the motor-to-thrust chamber coupling guard so the motor and pump can be periodically rotated.
9. Using a strap wrench on the motor shaft, rotate the pump and motor 10 revolutions once a week.

Private

Copyright © 2008 Schlumberger, Unpublished Work. All rights reserved.

10. Remove the motor drain plugs on a monthly basis and verify that the drains are open and functioning properly.

7.5 Recommissioning Procedures

The following recommissioning procedures should be performed for horizontal pump systems that have been decommissioned and are being prepared for return to service.



Note

If the HPS has been moved or relocated, a complete commissioning procedure should be performed including a motor-to-thrust chamber coupling alignment and a pump-to-intake alignment.

1. Change the thrust chamber oil. If a cooling system is installed, the reservoir should be cleaned and the filter replaced.
2. Using a strap wrench around the motor shaft, rotate the pump and motor through 10 revolutions.
3. Change the motor bearings oil or grease the motor bearings.
4. Inspect the motor-to-thrust chamber coupling. If the coupling is a Falk greased coupling, clean and lubricate the coupling. Disc couplings do not require lubrication but should be cleaned if required.
5. Replace the motor-to-thrust chamber coupling guard.
6. During prolonged shutdown periods the inlet pressures may have increased. Ensure that the HPS inlet maximum pressure limit will not be exceeded.
7. Slowly open the intake valve to charge the system with fluid. On units with cartridge seals, slightly open the seal flush lines to expel any air and to verify fluid flow. The seals will fail on start-up if the seal flush is not working. If a unit has been idle for six months or more, remove the seals and send them to the seal manufacturer for cleaning and inspection.
8. Open and flush all lines to pressure switches and transducers. Close lines.
9. Verify that all instruments are operational and are properly set.

Private

Copyright © 2008 Schlumberger, Unpublished Work. All rights reserved.

10. If any guards and safety equipment have been removed, ensure they have been reinstalled.
11. Ensure that the HPS is compliant with all electrical, mechanical and process parameters and settings of the design.
12. Remove all lock-out/tag-out items and restart the HPS in accordance with start-up procedures.

Troubleshooting

8.1	Troubleshooting Basics	8-1
8.2	Troubleshooting Electric Motors and Starters	8-2
8.3	Troubleshooting Thrust Chamber Vibrations	8-5
8.4	Troubleshooting Thrust Chamber Overheating (The HPS Unit Has a Thrust Chamber Cooling and Filtration System)	8-7
8.5	Troubleshooting Thrust Chamber Overheating (The HPS Unit Does Not Have a Thrust Chamber Cooling and Filtration System.)	8-8
8.6	Troubleshooting Instruments	8-10
8.7	Troubleshooting Gearbox Noise	8-11
8.8	Troubleshooting Gearbox Overheating	8-11
8.9	Troubleshooting Gearbox Vibration	8-11
8.9.1	Linear Vibration	8-12
8.9.2	Torsional Vibration	8-12

Intentionally Blank

8 Troubleshooting

8.1 Troubleshooting Basics

Much of the work performed by technicians involves the maintenance and repair of equipment and systems. Technicians must have a good knowledge of what is commonly referred to as troubleshooting to maintain the equipment and systems at peak performance.

Troubleshooting is the ability to determine the cause of a problem and then correct it. Troubleshooting covers a wide range of problems from simple jobs such as changing oil in a thrust chamber to finding a short circuit or tracing out defects in a complex pumping system. The basic principles used are the same in all cases. Troubleshooting requires a thorough knowledge of electrical theory, hydraulic theory and mechanical theory combined with a systematic and methodical approach to find a diagnose the problem. Troubleshooting also requires the use of appropriate test equipment.

The following general principles and tips will help define the troubleshooting process.

Think Before Acting

Thoroughly study the problem and then ask the following questions.

- Were there any warning signs preceding the trouble?
- Has any previous repair and maintenance work been done?
- If the circuit, component or system is still operational, is it safe to continue operation before further testing?

Answers to these questions can usually be obtained by:

- questioning the owner or operator of the equipment
- taking time to think the problem through
- looking for additional symptoms
- consulting troubleshooting charts
- checking the simplest things first
- referring to repair and maintenance records

Private

Copyright © 2008 Schlumberger, Unpublished Work. All rights reserved.

- checking with calibrated instruments
- double-checking all conclusions before beginning any repair on the equipment or circuit components.

**Note**

Always check the easiest and obvious things first. Following this simple rule will save time and trouble.

The source of many problems can be traced not to one component alone but to the relationship of one component to another. For example, a tripped circuit breaker can be reset to restart the unit, but what caused the circuit breaker to trip? It could have been caused by a vibrating energized conductor momentarily coming into contact with ground, a loose connection causing overheating or any number of causes. Often, electrically-operated equipment is completely disassembled in search of the cause of a certain complaint and all evidence is destroyed during the disassembly process. Check to be certain an easy solution to the problem has not been overlooked.

Find and Correct the Problem

After an electrical or mechanical failure has been isolated, be sure to correct the cause so the same failure will not be repeated. Further investigation may reveal other faulty components.

Although troubleshooting charts and procedures will help in diagnosing problems, they can never be complete. There are many variations and solutions for a given problem.

8.2 Troubleshooting Electric Motors and Starters

Electric motors use the principle of electromagnetic induction. An induction motor has a stationary part (stator) with windings connected to the power supply and a rotating part (rotor) that contains coils or bars. The stator and rotor are not electrically connected. The magnetic field produced in the stator windings induces a voltage in the rotor coils or bars.

When an electric motor malfunctions, the stator windings are usually defective and will require repair or replacement. Stator problems can usually be traced to one or more of the following causes:

- worn bearings
- moisture

Private

- overloading
- operating in a single-phase mode
- poor insulation.

Dust and dirt are usually contributing factors. Some types of dust are highly conductive and materially contribute to insulation breakdown. The effect of dust on the motor temperature (through restriction of ventilation) is another reason for keeping the motor clean by periodically blowing it out with compressed air or washing out the fins. The compressed air must be dry and delivered at low pressure to prevent insulation damage.

One of the worst enemies of motor insulation is moisture, therefore, the motor insulation must be kept as dry as possible. If a motor must be operated in a damp location, the windings should receive a special moisture-resistant treatment.

The winding life depends on keeping it in its original condition as long as possible. In a new machine, the winding is snug in the slots and the insulation is fresh and flexible. This condition is best maintained by periodic cleaning, followed by varnish and oven treatments. After the insulation dries out, it loses flexibility and the mechanical stresses caused by starting and plugging as well as the natural stresses in operation under load will tend to cause the coils to short circuit. Failures from the coil to ground will usually be at the point where the coil leaves the slot. The effects of periodic varnish and oven treatments properly carried out so as to fill all air spaces caused by drying and shrinkage of the insulation will maintain a solid winding and will also provide an effective seal against moisture.

Starters

Starters provide an electrical connection to the motor. A typical starter consists of a manual disconnect that isolates the incoming power from the rest of the equipment, a contactor that is energized by a control circuit, a control power transformer that reduces incoming line voltage to a low voltage of 110 VAC or 220 VAC and a control circuit.

[Table 8-1](#) provides troubleshooting information for electric motors and starters.

Table 8-1: Troubleshooting electric motors and starters

Symptom	Remedy
The starter does not engage.	<ol style="list-style-type: none"> 1. Verify that the main disconnect is energized. 2. Determine if the control power transformer has output power. Verify that the instrument loop has voltage at both terminals. If voltage is missing at one terminal, a part of the safety circuit is not closed. The wiring diagram for the skid will have to be used to troubleshoot the instruments. Determine which instrument has the open contact and adjust the switch or repair the wiring. The low-discharge-pressure switch will be tripped because the unit is not running. A time-delay relay can be used to bypass the low-discharge-pressure switch or the switch can be adjusted to get the unit running. Reset the switch after the pump is running. 3. Determine if the start push button is functional. Determine if there is voltage at the power terminals of start push button. Verify the starter push button is mechanically functional. 4. Determine if the start relay is energizing. 5. Determine if the starter energizing coil is functional. If the coil is energizing, the starter may have mechanical defects and should be repaired by a starter repair facility.

Symptom	Remedy
The starter energizes but the motor does not make any noise or attempt to rotate.	<ol style="list-style-type: none"> 1. Tag out and lock out the main disconnect to the starter. 2. Verify that the motor power cables are connected to the starter. 3. Open the motor main input power junction box and verify that the motor leads are connected to the correct power cables from the starter.
The starter energizes and the motor makes noise or attempts to rotate.	<ol style="list-style-type: none"> 1. Tag out and lock out the starter. 2. Attempt to rotate the motor and pump by hand. 3. If the pump and motor freely rotate, verify that the motor power leads are connected. If the leads are properly connected, perform a megger test on the motor and leads at the starter. If the resistance is low, disconnect the motor leads and power leads and perform separate megger tests. Replace defective power leads or repair or replace the motor. 4. If the pump and motor do not freely rotate, uncouple the motor from the thrust chamber. <ul style="list-style-type: none"> • If the thrust chamber and pump freely rotate but the motor does not, remove the fan cover and check the fan for binding. If the fan is not binding, the motor is defective. Repair or replace the motor. • If the motor rotates but the thrust chamber and pump do not freely rotate, disconnect the pump from the skid intake. Pull the pump far enough away from the intake to remove the coupling between the thrust chamber and the pump. Attempt to rotate the pump by hand. If the pump will not rotate, replace the pump. Attempt to rotate the thrust chamber. If the thrust chamber will not rotate, replace the thrust chamber.

8.3 Troubleshooting Thrust Chamber Vibrations

The thrust chamber is located between the motor and the pump intake. Its main function is to absorb the thrust loads generated by the pump. Fluid migration into the thrust chamber is prevented by a mechanical seal located on the suction side of the thrust chamber subassembly. Thrust chambers are subject to regular preventive maintenance.

[Table 8-2](#) provides troubleshooting information for thrust chamber vibrations.

Private

Copyright © 2008 Schlumberger, Unpublished Work. All rights reserved.

Table 8-2: Troubleshooting Thrust Chamber Vibrations

Symptom	Remedy
<p>The thrust chamber vibration exceeds limits. Vibration is high at the motor coupling bearing.</p>	<ol style="list-style-type: none"> 1. Compare the vibration measurement to the motor vibration measurement at the motor output shaft bearing. 2. If the motor vibration measurement in the same orientation is equal or close to equal, perform a complete alignment on the motor. Soft foot must be checked and corrected if present. 3. If the thrust chamber vibration is higher than the motor vibration, shut the unit down and disassemble the coupling. 4. Rotate the thrust chamber by hand. If roughness in bearings is felt, replace the thrust chamber. 5. If roughness in the bearings is not felt, check the thrust chamber endplay. The maximum endplay is 0.015 in. Replace the thrust chamber if the endplay exceeds 0.015 in.
<p>The thrust chamber vibration exceeds limits. Vibration is high at the pump end bearing.</p>	<ol style="list-style-type: none"> 1. Compare the measurements in the vertical and horizontal planes. If the vertical vibration measurement is acceptable and the horizontal vibration measurement exceeds the limit, check the horizontal vibration on the intake adaptor and the pump. If the measurements are close to the same, the problem is probably flow-induced vibration. Flow-induced vibration only occurs in the horizontal plane. (The intake adapter, the pump end bearing on the thrust chamber and the base of the pump before the first clamp are common locations for measuring flow-induced vibrations). 2. If the vertical and the horizontal measurements are equal, then the thrust chamber endplay should be measured. On Gen2-series skids, the thrust chamber and mechanical seal are removed as an assembly. 3. Check the endplay in the thrust chamber. The maximum endplay is 0.015 in. Replace the thrust chamber if the endplay exceeds 0.015 in.

8.4 Troubleshooting Thrust Chamber Overheating (The HPS Unit Has a Thrust Chamber Cooling and Filtration System)

The thrust chamber is located between the motor and the pump intake. Its main function is to absorb the thrust loads generated by the pump. Fluid migration into the thrust chamber is prevented by a mechanical seal located on the suction side of the thrust chamber subassembly. Thrust chambers are subject to regular preventive maintenance.

[Table 8-3](#) provides troubleshooting information for thrust chamber overheating problems on HPS units with a thrust chamber cooling and filtration system.

Table 8-3: Troubleshooting Thrust Chamber Overheating Problems on HPS Units With a Thrust Chamber Cooling and Filtration System

Symptom	Remedy
The thrust chamber is overheating.	<p>Check the oil level. Add oil if necessary.</p> <p>Verify the temperature measurement. If the measurement is taken with an infrared thermometer, the oil temperature should also be measured with an immersion thermometer. The maximum oil temperature is 180 degF (82 degC).</p>

Symptom	Remedy
The oil temperature exceeds the maximum limit.	<p>Check for oil contamination. If the oil is contaminated, change the oil and filter and allow the thrust chamber to operate with clean oil until the temperature has stabilized.</p> <p>Determine if the cooling system pump is operating. If the pump is not operating, refer to <i>The cooling system pump is not running</i>.</p> <p>Check the cooler fins for debris.</p> <p>Verify that the fan is circulating air.</p> <p>Verify the pump is circulating oil. Measure the temperature of the oil at the thrust chamber discharge. Measure the temperature of the oil at the oil cooler discharge. The temperature of the oil leaving the cooler should be less than the temperature of the oil leaving the thrust chamber. If the temperatures are similar, the oil may not be flowing. If the oil is not flowing, verify the coupling between the cooling system pump and motor is operational. If the pump is running but oil is not flowing, replace the pump.</p>
The cooling system pump is not running.	<p>Verify there is power at the motor leads. Connection 4 and connection 5 on the wiring diagram are the motor leads on a 120 volt system.</p> <p>If there is no power, troubleshoot the cooling system motor starter.</p> <p>If there is power at the motor leads, shut down the cooling system motor and lock it out. (The thrust chamber will retain enough oil to operate for up to an hour without damage. After an hour without oil circulation, the thrust chamber may overheat, therefore, shutdown the HPS pump motor. On cooling systems with pressure/flow interlocks to the main HPS pump motor the interlocks will have to be bypassed.) Disconnect the coupling between the motor and pump by loosening the setscrew on the motor shaft and moving the motor back from pump. Leave the motor leads connected. After the coupling is removed, attempt to start the motor. If the motor does not start, replace the motor. Also, turn the pump by hand. If the pump will not turn smoothly, replace the pump.</p>

8.5 Troubleshooting Thrust Chamber Overheating (The HPS Unit Does Not Have a Thrust Chamber Cooling and Filtration System.)

The thrust chamber is located between the motor and the pump intake. Its main function is to absorb the thrust loads generated by the pump. Fluid migration into the thrust chamber is prevented by a mechanical seal located on the suction side of the thrust chamber subassembly. Thrust chambers are subject to regular preventive maintenance.

[Table 8-4](#) provides troubleshooting information for thrust chamber overheating problems on HPS units without a thrust chamber cooling and filtration system.

Table 8-4: Troubleshooting Thrust Chamber Overheating Problems On HPS Units Without a Thrust Chamber Cooling and Filtration System.

Symptom	Remedy
<p>The thrust chamber is overheating.</p> <hr/> <p>i Note Also refer to <i>Special Conditions</i> below.</p>	<p>Verify the temperature measurement. If the measurement is taken with an infrared instrument, the oil temperature should also be measured with an immersion thermometer. The maximum oil temperature for systems containing Royal Purple Synfilm 48 GT is 180 degF (82 degC).</p>
<p>The oil temperature exceeds the maximum limit.</p>	<p>Check for oil contamination. If the oil is contaminated, change the oil and filter and allow the thrust chamber to operate with clean oil until the temperature has stabilized. If the oil temperature still exceeds the limit, replace the thrust chamber.</p> <p>If the thrust chamber is noisy, check for high vibration levels. Replace the thrust chamber if vibration levels exceed the maximum limits.</p> <hr/> <p>i Note If the thrust chamber is replaced, it should be replaced by a duplicate unless the pump service has changed. The problem may be that the original thrust chamber was an LT or single-thrust-bearing model. If the operating conditions are not the same as the original design, then a three-bearing thrust chamber may be required.</p>
<hr/> <p>i Note Special Conditions:</p> <p>An oil cooler may be required if the thrust chamber does not have an oil cooler and has a history of running hot.</p> <p>If the client has substituted another oil for the recommended oil, the substituted oil may be the cause of high oil temperatures. Royal Purple Synfilm 48 GT belongs to a class of synthetic oils with a PAO base. Any oil that does not have a PAO base may not cool properly. The HPS thrust chamber is designed to operate at higher temperatures in the thrust chamber (bearing section) than most pumps. The thrust chamber oil must withstand the higher temperatures. The PAO-base synthetic oils will withstand the higher temperatures. Synthetic oil is also used to prevent water contamination on units that start and stop frequently. A warranty claim on a thrust chamber that has been operated with non-recommended oil will not be honored.</p>	

8.6 Troubleshooting Instruments

Instruments are the control devices for HPS units. The instruments perform two basic functions.

- Interface to a pump control device.
- Instruments have a safety shutdown mechanism in case of a system malfunction. Low suction or discharge pressure, vibration or high component temperatures are a several of the parameters that can be monitored.

Table 8-5 provides troubleshooting information for instruments.

Table 8-5: Troubleshooting a Motor Starter That Does Not Engage. Before using the following table, first determine if the instrument loop has voltage on both terminals.

Symptom	Remedy
The instrument loop does not have power on both terminals.	Determine if the control power transformer has voltage at the output terminals. If there is no power at the output terminals, determine if there is input power. If there is no input power, repair as required.
The control power transformer has output power.	<p><i>This procedure applies to skids with pressure, temperature and vibration switches.</i> Determine if the instrument loop has voltage at both terminals. If voltage is missing at one terminal, a part of the safety circuit is not closed. The wiring diagram for the skid should be used to troubleshoot the instruments. Determine which instrument has the open contact and adjust the switch, repair wiring or replace the switch.</p> <p>The low-discharge-pressure switch will be tripped because the unit is not running. A time-delay relay can be used to bypass the low-discharge-pressure switch or the switch can be adjusted until it makes to get the pump running. Adjust the low-discharge-pressure switch after the pump is running.</p>
The control power transformer has output power.	<p><i>This procedure applies to skids with pressure, temperature and vibration transducers.</i> The control power transformer power loop to the start relay is routed through a relay operated by the transducer reader. This device is normally a programmable logic controller.</p> <p>The programmable logic controller is programmed before the skid is shipped. The programmable logic controller set points can be adjusted by field personnel. The programmable logic controller is code protected. The code is in the skid operations manual that was shipped with the skid. For all units with transducers, the operations manual must be available to start and troubleshoot the unit.</p>

8.7 Troubleshooting Gearbox Noise

Gearbox noise is sometimes difficult to diagnose without sophisticated vibration measurement tools.

A high-pitch “whine” is usually noise from a deteriorating gear. The whine is generated by the tooth meshing frequency. For example, an input gear with 30 teeth running at 1800 rev/min has a meshing frequency of 900 Hz. This compares to a shaft rotation frequency of 30 Hz ($1800 \div 60$).

Bearings rotate at input shaft speed or some increasing or decreasing multiple thereof. The rotational frequency of the shaft is several orders of magnitude below the gear mesh frequency, therefore, the noise produced by bearings that are failing is closer to a “growl” or a frequency much lower than gear mesh frequency. In advanced stages of failure, the bearings may slide, producing a screeching noise. Failing bearings usually generate excessive heat; look for hot spots on the gearbox.

Pinpointing gearbox noise is difficult, especially on systems without torsionally tuned couplings. Noise transfers via shafts and other rigid members and often sounds as though it is coming from a gearbox when it may actually be transmitted there from another source. A “listening rod” may be helpful to locate the noise.

8.8 Troubleshooting Gearbox Overheating

The most frequent cause of overheating is oil level; either too little or too much. Too little oil can result in reduced or no delivery or to moving parts causing high friction and heat. Too much oil increases agitation by gears, bearings and other moving parts, generating excess heat.

Do not add more oil than necessary. Oil levels are determined experimentally at the factory. If there are special circumstances such as pitch, roll or jerky motion, contact [InTouchSupport](#) for technical assistance.

8.9 Troubleshooting Gearbox Vibration

Vibration can generally be divided into two categories, linear and torsional.

8.9.1 Linear Vibration

Linear vibration is the most familiar. This is the shaking and movement of equipment that is easily felt and heard. As a rule, linear vibrations are related to a mechanical problem such as imbalance or misalignment. Linear vibration can also be a result of advanced gear or bearing wear. Typically, linear vibrations worsen as speeds increase. Automobile tire imbalance is an example of linear vibration. As speed increases, the vibration increases in both frequency and amplitude; the faster the tire turns the worse the imbalance becomes.

The damage from linear vibration is usually not surprising. For example, a severely out-of-balance pulley can easily cause a shaft bearing to fail.

8.9.2 Torsional Vibration

Torsional vibrations are difficult to identify because they often cannot be felt. Torsional vibrations usually exist only at certain speed and load conditions and often "come and go" with speed changes. Torsional vibrations exist to some extent in all rotating systems but are not normally a problem unless the system is driven or "excited" by a frequency source that is at or near the natural frequency of the system (resonance). Systems operating at resonance can generate forces equal to several times the expected forces.

Torsional analysis can predict the speeds at which a system may become resonant allowing designers to redesign the system and use various components such as torsional couplings and mass dampeners. Torsional analysis is typically performed by the system packager or a torsional coupling manufacturer.

Torsional vibrations generally cause unexpected damage. For example, a gear may wear or break shortly after being placed in service or a shaft may break unexpectedly even though it is oversized. When there seems to be no explanation for component failures - consider torsional vibrations.

One particularly alarming torsional condition is full reversing in which applied torque actually passes back and forth through zero. If a gearbox is subjected to a full reversing torque, a severe rattle can occur as the gear teeth load and unload. The noise generated by this action can be quite loud. Keep in mind that the gearbox may not be causing the noise. The problem is that a severe torsional condition exists; not a defective gearbox.

If torsional or linear vibrations are suspected as a possible problem, contact InTouchSupport for technical assistance.

Private

Copyright © 2008 Schlumberger, Unpublished Work. All rights reserved.